

INNOVATIONS
MASTER CATALOGUE

CUTTING TOOLS
2013



www.kennametal.com

 **KENNAMETAL®**

GENERAL ENGINEERING

TRANSPORTATION

www.kennametal.com



AEROSPACE & DEFENSE

EARTHWORKS

ENERGY

 **KENNAMETAL®**



Since its inception in 1938, Kennametal has understood precisely how to improve manufacturing performance and profitability — by introducing unparalleled products and services to reduce operating costs and lead times.

These 2000+ pages bring you the latest in milling, holmaking, turning, and tooling systems products and superior services — all specifically engineered to enhance overall productivity, even in the most challenging metalworking applications. Rely on Kennametal to significantly boost manufacturing competitiveness. To learn more, contact your Kennametal Representative or Authorised Kennametal Distributor.

Visit us at www.kennametal.com.

Table of Contents

Introductioni–xvii
Services and Supportxviii–xxxI
Stationary Tools	
Turning Introduction	A0–A3
ISO Inserts	B0–B130
PCBN/PCD Inserts	B132–B197
O.D./I.D. Tooling	C0–C147
Grooving and Cut-Off	D0–D145
Threading	E0–E103
Application Specific	F0–F131
Rotating Tools	
Holemaking Introduction	0–9
Solid Carbide Drills	G0–G97
Modular Drills	H0–H47
Combination Tools	I0–I23
Indexable Drills	J0–J79
Hole Finishing	K0–K205
Taps	L0–L117
Solid End Milling	M0–M143
Indexable Milling Introduction	N0–N19
Face Mills	O0–O153
Shoulder Mills	P0–P87
Slotting Cutters	Q0–Q61
Copy Mills	R0–R123
Thread Mills	S0–S15
Index by Order Number	T2–T65
Index by Catalogue Number	T66–T135
Global Contacts	U2–U3
Icon Legend	U4–U7

Less Environmental Impact

To learn more about our sustainable solutions for your industry,
please contact your Kennametal Representative or
Authorised Kennametal Distributor, or visit www.kennametal.com.

Environment

Kennametal's intimate understanding of the energy marketplace — including customer processes and applications — allows us to proactively address production and sustainability concerns with solutions tailored to your needs. We deliver superior value because we listen closely to you, our customer, and innovate based on your feedback. Our goal is to help you be more competitive — both at home and on a global scale.



Best Practices in Productivity

As your trusted partner for optimised production, Kennametal offers customers a unique commitment to research and development excellence, continually delivering highly innovative ways to enhance productivity. Certification to ISO 9001, QS 9000 TES, and VDA 6.4 provides the highest possible quality standards.

Best Performance, Less Environmental impact

With technology, we can do both. Kennametal helps customers focus on the root causes of unsustainable behavior in highly complex manufacturing systems, while at the same time improving cost structure, quality, and performance. In addition to offering the latest in metalcutting tools and technology, our Advanced Engineering team will analyse your existing production processes and help identify new methods to improve your overall performance.

Turning

Product Highlights

Superhard Materials • PCBN and PCD

Abrasion resistance and toughness are the two most important properties in assessing the efficiency of cutting tool materials. Abrasion resistance is primarily a function of hardness, and, in this respect, diamond (PCD) and cubic boron nitride (CBN) are superior to all other known materials.

For more information, see pages B132–B197.

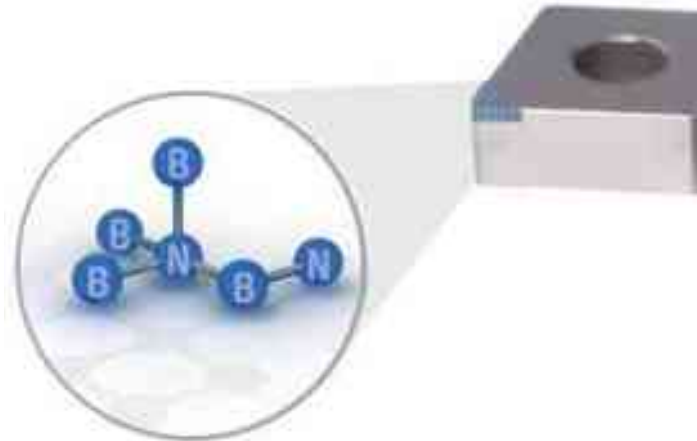

Beyond BLAST™

An entirely different approach to machining high-temperature alloys. We determined that the most effective way to deliver coolant would be to channel it through the insert — ensuring that it hits exactly where it does the most good. That means, more efficient coolant delivery at a fraction of the cost of high-pressure coolant systems. By precisely controlling coolant application, Beyond BLAST enables you to lower your energy consumption, saving you even more money and reducing your impact on the environment.

For more information, see pages F2–F11.

beyond BLAST™



Beyond™ PVD Grades

Advanced PVD coatings using Beyond technology are well suited to resist the high temperatures associated with machining tough alloys. By offering increased tool life (by 30–40%), the general engineering, transportation, aerospace, energy, and earthworks markets can experience benefits in their profitability. They can also realise benefits by utilising the strength of the new PVD coating in combination with the broad product offering to perform turning, grooving, and cut-off operations in a wide array of materials and applications while maintaining consistent chip control and minimising insert edge wear.

For more information, see pages B2–B115.



Grooving and Cut-Off : -CL and -GUP Geometries

The A2™ CL geometry maximises your cut-off productivity. The A2-CL geometry offers tighter chipbreaker capabilities when machining low-carbon steel, excellent chip evacuation in low-feed applications, and improved stability and rigidity. The A4-GUP geometry, available in moulded and precision-ground styles, provides a positive rake angle, enhanced chip control, and lower cutting forces. The -GUP geometry offers up to 180% longer tool life and higher productivity in steel, stainless steel, and high-temperature alloy materials.

For more information, see pages A2-CL: D13
A4-GUP: D70, D73–D74.

Kennametal Select

Kennametal Select products make it simple to get the most out of your inserts — and your money. Every insert is gold, which exposes wear as the tool continues to be used. This makes it easy to detect when an insert is ready to be changed — maximising the product's value and protecting the workpiece. Also, because Kennametal Select inserts can be used in most applications, a single insert can take on any number of tasks, thus reducing your inventory. Kennametal Select products are also reliable enough to cut steel, stainless steel, cast iron, and high-temperature alloys, enabling quick changes in workpiece materials without the need to swap inserts, saving time and money.

For more information, see pages F106–F130.



Holemaking

Product Highlights



Hole Finishing with Kennametal

Only Kennametal is capable of offering you the best, customised solution for your application. Kennametal owns the entire process chain, from raw material, insert pressing, tool body design, brazing, sintering, grinding, coating, and so on, up to reconditioning. Kennametal is the only source in the metalworking industry from where you can get all types of hole finishing tooling, from reaming and fine boring to motion tooling, directly from one hand. Therefore, Kennametal can offer you the best-fitting solution for your machining challenge, giving you the choice of tooling without any limitations in regard to portfolio or capability.

For more information, see pages K1–K205.

Drill Fix™ DFS™

Drill Fix DFS combines the economical squared-outboard insert with the superior centring capabilities of the trigon inboard insert. The DFS indexable drills offer increased metal removal rates combined with high surface quality and hole straightness.

For more information, see pages J14–J22.



GOdrill™ • Kennametal's First Microdrill

The all new GOdrill addresses drilling operations in a diameter range of 1–12,7mm (.0394–.5") in a broad variety of materials and applications, such as fuel systems or medical components. Due to its very unique design, the GOdrill expands the advantages of modular drills into the small diameter range: high-end grades, wear-indicator coating, and new, patented geometries enable full utilisation of the drill's tool life capacity.

For more information, see pages G5–G14.





HP Beyond™ Drills for Steel and Stainless Steel

HP Beyond Series Solid Carbide Drills are designed specifically for stainless steel and steel applications, offering high performance and long tool life in regular steel, titanium, and iron materials. By combining unique Kennametal technologies, such as the HP point, flute geometry, and a new Beyond grade technology into one tool, the B2_HP Beyond is the ultimate high-volume production tool.

For more information, see pages G21–G37.

KSEM PLUS™ Modular Drill System

The KSEM PLUS drill concept is simple but effective. It combines the benefits of the KSEM™ modular drill (high feeds and length-to-diameter [L/D] ratios) with the benefits of an indexable drill (high speeds and low consumable costs).

For more information, see pages H36–H47.



Beyond™ High-Performance Solid Carbide Taps

Solid carbide taps offer higher productivity and outstanding performance in a wider range of materials than formerly possible. Get more production from a single tool and superior accuracy of product thread that surpasses the competition. Kennametal High-Performance Solid Carbide Taps are available in various specifications with enhanced precision and design, which translates into longer tool life, excellent performance, and exceptional wear resistance.

For more information, see pages L2–L29.

Solid End Milling

Product Highlights



HARVI™ High-Performance End Mills for Roughing and Finishing with One Tool

HARVI takes high-performance roughing, semi-finishing, slotting, and profiling to the next level. The line is designed to provide maximum metal removal rates and achieve supreme surface conditions. A wide range of diameters and corner radii are available from stock.

For more information, see pages M10–M25.

KenFeed™ End Mills for High-Feed Milling

A unique tool with new, 6-flute style for high productivity, the KenFeed end mill is specifically engineered to machine hardened steel up to 67 HRC at extreme speeds and feeds. Necked shanks provide extended reach in deep cavities and high feed rates up to 0,6mm per tooth on a 20mm tool. Machine hardened materials at 2–3x the metal removal rate of competitive end mills. Wide range of cutting diameters, down to 6mm for small- and medium-pocket work. Innovative new geometry maximises metal removal rates and lowers manufacturing costs.

For more information, see pages M26–M30.



KCN05™ Diamond Coated Carbide Routers

Kennametal has the correct milling solutions engineered for machining difficult CFRP (Carbon-Fibre Reinforced Polymer) and non-ferrous components. KCN05 solid carbide router products provide excellent tool life and produce smooth finishes with improved edge quality. The unique geometries are free cutting, reduce heat generation, and provide high-quality machined surfaces.

For more information, see pages M65–M71.





GOMill™ • The Economical Milling Cutter Line

The GOMill line is specifically engineered to work on short length-of-cut applications in multiple workpiece materials, like soft and hard steels up to 48 HRC, stainless steels, high-temperature alloys, and cast iron. With the very short overall length and soft cutting geometries, the line is made to conform to the growing market of mill-turn machines. The 3-flute sharp and 4-flute chamfer versions support roughing, semi-finishing, and finishing applications; the 3-flute ball nose tool supports roughing and semi-finishing applications; and the 2-flute ball nose version supports finishing applications. All three geometries work in slotting as well as side milling applications up to 1 x D depth of cut.

For more information, see pages M117, M122, M126, M130.



MaxiMet™ Carbide End Mills for High Metal Removal Rates and Superior Surface Finishes

Designed to significantly reduce machining time in aluminium! The innovative geometry designs include a wiper facet for superior surface finish on aluminium parts. MaxiMet takes roughing and finishing cuts with one tool. Slotting is effective up to full 1 x D axial depth. Side milling is effective up to 0,5 x D radial and 1,5 x D axial depth. The 3-flute series uses unequal flute spacing for chatter-free performance. Effective in a full range of machine speeds. Multiple corner radii and extended neck configurations are available as standard.

For more information, see pages M50–M53.

Indexable Milling

Product Highlights

Dodeka™ Series • Leader in Advanced Face Milling Applications

Dodeka Mini and Dodeka MAX™ are the most comprehensive face milling boosters on the market today. Twelve true cutting edges per insert mean low cost per edge and high productivity. With Beyond™ premium milling grades, you will see up to 30% higher Metal Removal Rates (MRR), 25% lower cutting forces due to real soft cutting action, and up to 35% better tool life in light to heavy machining.

For more information, see pages O2–O29.



MEGA Series • Superior Heavy-Duty Milling

With four true cutting edges per heavy-duty MEGA insert, you know you are getting the low cost per edge and high productivity you need and have come to expect from Kennametal. The soft cutting edge design enables 30% lower cutting forces, and the carbide shim provides protection to the cutter body. Choose MEGA inserts for all of your steel and cast iron indexable milling needs.

For more information, see pages O30–O47.



Beyond BLAST™ • More Than Just the Right Tool — The Ultimate Solution

The Beyond BLAST KSSM™ 45° and KSRM™ platforms utilise Precision Coolant Technology (PCT) to aggressively apply coolant directly to the cutting area. Not only does this reduce heat at the cutting edge, but it also assists with reducing tool and chip friction, increasing chip evacuation, and relieving shear stress.

For more information, see pages O48–O53.



Rodeka™ • The New Round Insert Generation

Kennametal introduces a new and revolutionary double-sided round milling insert capable to run in multiple types of milling operations and workpiece materials, providing the latest double-sided insert technology to boost your productivity with the most efficient cost per edge.

For more information, see pages R12–R19.

Mill 1™ • High-Performance Shoulder Milling Platform

The multifunctional Mill 1 platform works with all tool materials in shoulder, ramp, slot, plunge, and helical milling with one insert style to improve productivity and reduce inventory and machining costs. The super positive cutting rake, soft cutting action, and low cutting forces enable higher feed rates and spindle protection. Innovative insert and cutter body designs offer improved ramping capabilities.

For more information, see pages P2–P62.



Tooling Systems

Product Highlights

New Catalogue

New Comprehensive Tooling Systems Catalogue

Kennametal is proud to present the latest Kennametal Tooling Systems catalogue with innovative products on more than 1,100 pages! In this catalogue, you will find information about KM Micro™, KM Mini™, KM™ Quick Change, KM4X™, HSK shank tools, BTKV and CVKV shank tools, BT shank tools, CV shank tools, DV shank tools, QC and R8 shank tools, straight shanks, collets and sleeves, and thermo shrinking machines.

To view the PDF, please go to www.kennametal.com

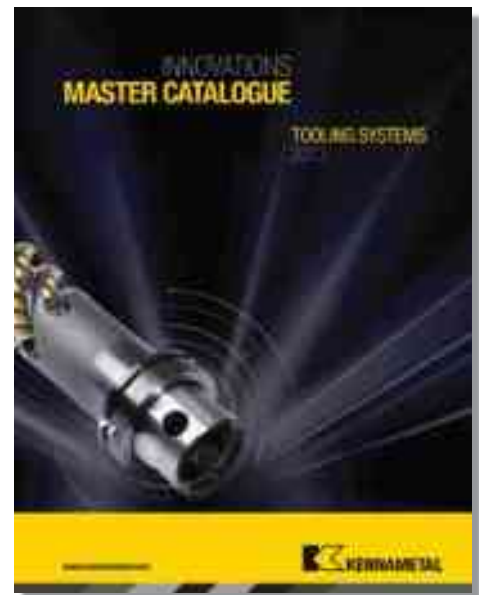



KM4X™ • The New Choice for Heavy-Duty Milling

KM4X is the latest version of the KM™ spindle interface targeted at heavy-duty machining operations and is a top choice for machining large, structural, tough-to-machine materials, like titanium, for the aerospace industry. The portfolio consists of rotating adaptors and static tooling to support the tough and heavy machining markets. Additional products include spindle component packages as well as static clamping units to support turning and mill-turn opportunities.



KM™ Quick Change

KM Quick Change Tooling is a central component in achieving dramatic improvement in machine and cutting tool use. It's the choice of manufacturers requiring maximum machine output. The necessary tasks of changing, setting up, and gaging tools create an excess of machine downtime. For small batch manufacturing operations requiring these frequent setups, KM Quick Change Tooling is the most efficient method for reducing lost time and improving the overall quality of the machining process by generating greater productivity and increasing profits.

HSK Shank Tools

ERICKSON™ HSK Face Contact short taper tooling is manufactured from premium materials and to the latest DIN/ISO specification standards. Form A versions are generally used in machining centres and milling machines with automatic tool changers.





Engineered Solutions

Coordinated global resources with world-class manufacturing process development and implementation capabilities.

Whether it's a single tailored tool required to address a specific part feature or the development of a comprehensive manufacturing process for use on existing or newly acquired production equipment, Kennametal's team can manage the development, personnel training, and successful implementation of the complete solution.

Global implies just that. Globally coordinated manufacturing process development, implementation, and optimisation support at machine tool builders, end user engineering or corporate offices, and end user production facilities, regardless of their respective geographies. Well-organised, highly linked staff reside in the Americas, Europe, and Asia/Pacific regions. Globally standardised design and manufacturing systems enable highly coordinated project management and implementation results.

Key alliances with machine tool builders and other leading manufacturing technology enablers ensure a complete solution, optimising the entire process — not just portions of it. This results in the most effective and efficient manufacturing process possible, leading to low implementation time and cost and rapid return on investment.

For more information, please contact us at 1.866.646.7113.





Energy

Energy Engineered Solutions

Kennametal is more than a supplier of tooling solutions. With a thorough understanding of the energy segment's process and application challenges, we proactively address production concerns to deliver productivity to customers seeking peak performance in demanding environments. Kennametal's success is based on our capabilities — our ability to work with you on customised solutions to optimise your results and our willingness to engage with a broad spectrum of materials, metalworking solutions, application and custom component manufacturing, and supply expertise. Our drive for success, enabled through our advanced materials sciences, application knowledge, and commitment to a sustainable environment, results in a broad portfolio of innovative, custom, wear-resistant solutions.



Please also see the new Kennametal Energy catalogue (B-11-02786).



Engineered Solutions

Automotive

Automotive Engineered Solutions

Traditionally, Kennametal has been a strong player in the transportation field, pioneering innovative solutions with automotive, shipbuilding, and railroad customers. We deliver global services and products that exceed our customers' expectations and continually push the boundaries of science. In today's competitive world, no one can support our customers better, and in turn, deliver the continued service and quality that has become Kennametal's trademark.

Kennametal's global reach has helped our customers standardise processes and products to improve both cost and quality. We offer an intimate understanding of the economics of the automotive value chain and unparalleled customised solutions tailored to your needs. We can deliver superior value by listening closely and innovating based on what our customers say. Our goal is to help you be more competitive, at home and on a global scale.



If it rolls, floats, or flies,



Aerospace

Aerospace Engineered Solutions

From lightweight composite materials to exotic alloys, Kennametal is committed to reducing risks and costs in the manufacture of aerospace and defense programs. We partner with customers to implement standard and customised solutions with minimum cost per part and high repeatability in mind. Kennametal has unique capabilities and resources to cover the total manufacturing equation from roughing to automated deburring and finishing. Kennametal's best-in-class technologies and services deliver up to 30% cost reduction and 60% cycle time reduction.

Aerospace component surfaces are one of the key battlegrounds in environmentally friendly manufacturing. Surface treatments not only improve appearance of the part but also enhance wear resistance, provide corrosion protection, and improve friction control. These subtle manufacturing enhancements provide big dividends in the form of fuel efficiency, reliability, performance, and longer part life.



Kennametal has a solution that delivers innovation and productivity.



Service and Support

Kennametal Extrude Hone™

Precision Surface Management

- Fuel efficiency through fine flow tuning — Diesel Fuel System (DFS) and Gasoline Direct Injection (GDI).
- Emission reduction due to better spray shaping.
- Noise, friction, and wear reduction for automatic gearbox components.
- Air flow path enhancement to improve jet or helicopter turbine performance.
- Energy savings with centrifugal impeller pump increased efficiency.
- Surface stress relief on high-pressured thin wall component for extreme safety.

Core Technologies Offer

- **Electrochemical Machining (ECM):** Generator, fixture, and cathodes
RADIUSING, shaping, polishing, surface stress relief.
- **Abrasive Flow Machining (AFM):** Media and fixture design
RADIUSING, polishing, surface stress relief.
- **Thermal Energy Method (TEM):** Controlled combustion
Minimising risk of hidden burrs and contamination.





Proven Solutions

Easy Access to Service and Support

- Engineering and Feasibility departments.
- Capital equipment solutions.
- Contract Shop activities (ramp up and production).
- Spare parts availability program.
- Metalcutting tooling combined with Precision Surface Management.
- Benefits of worldwide Kennametal logistics.
- Lean expertise to conduct global projects with customers.
- Cost per part solutions/Clic model for equipment.
- Parameters, cathodes, fixtures designs.
- Media design to part.
- Global Full Circle Program increases productivity resulting in less downtime of your equipment.





Service and Support

Kennametal Extrude Hone™

Proven Solution: Save Energy, Save Money

- Improving closed pump impellers inner flow passage roughness to increase up to 11% peak efficiency and lower energy consumption.
- A coal-powered plant equipped with six boiler feed pumps can reduce parasitic loss, representing at least \$500,000 annual savings (driving the pumps) by 1% of the power generated.
- This process and savings can also be applied to natural gas centrifugal closed pump impellers.

Precision Surface Management Matters

Kennametal Extrude Hone Abrasive Flow Machining (AFM) surface and flow enhancement solutions provide the energy segment with significant savings in pump efficiency improvements.

- The AFM process is the method of choice for material removal at the area of greatest restriction and surface improvement of passages not accessible by other methods.
- AFM has documented efficiency proven solutions in the automotive and aerospace industries.
- Two-way flow AFM process is a natural fit for closed impellers and diffusers.
- Inner flow passages of the impellers and diffusers benefit from AFM's selective material removal as well as surface finish improvement — both contributing to improved pump efficiency.

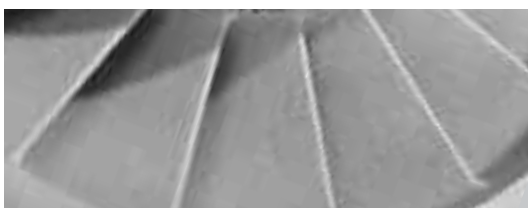

Before



After



Proven Solutions

Delivering Results throughout the Value Chain

Working with You

We have a strong focus on customer solutions, which helps develop an accurate understanding of industry needs. This is achieved through collaborative work with key players throughout the value chain:

Original Equipment Manufacturer (OEM)

Our business expertise is providing OEMs with key components, such as pumps, that deliver greater efficiency.

Foundry

Kennametal Extrude Hone™ specialists can bring added value early in the manufacturing chain, so you can deliver more than just a key component and exceed expectations every time.

End User

Currently in the best position to measure efficiency improvements, end users understand the direct impact of savings — anywhere along the value chain. They help us measure performance of the processed component against non-processed, providing a better understanding of efficiency improvement related to the Kennametal Extrude Hone AFM operation. The AFM Center of Excellence, in Irwin, PA, can perform feasibility testing with customer-specific parts to provide the optimal media needed for each process.

Media Is the Edge

The Kennametal Extrude Hone lab provides the energy industry with specific, engineered medias that deliver the highest performance for closed impeller polishing. We also have specific media with dedicated characteristics to enhance productivity and quality when polishing a closed impeller.





Service and Support

Kennametal Extrude Hone™

Abrasive Flow Machining for Pump Market Validation Testing

Formed in 1969 by a small group of pump engineers in Chicago, Hydro Aire is now the largest independent pump rebuilder with service centers throughout the world. A complete 5000 hp, 42,000 GPM pump test stand, designed in compliance with Hydraulic Institute standard and API 610, is located in Chicago. This is the ONLY independent non-OEM facility with this capability able to generate pump efficiency curves using LabView software.

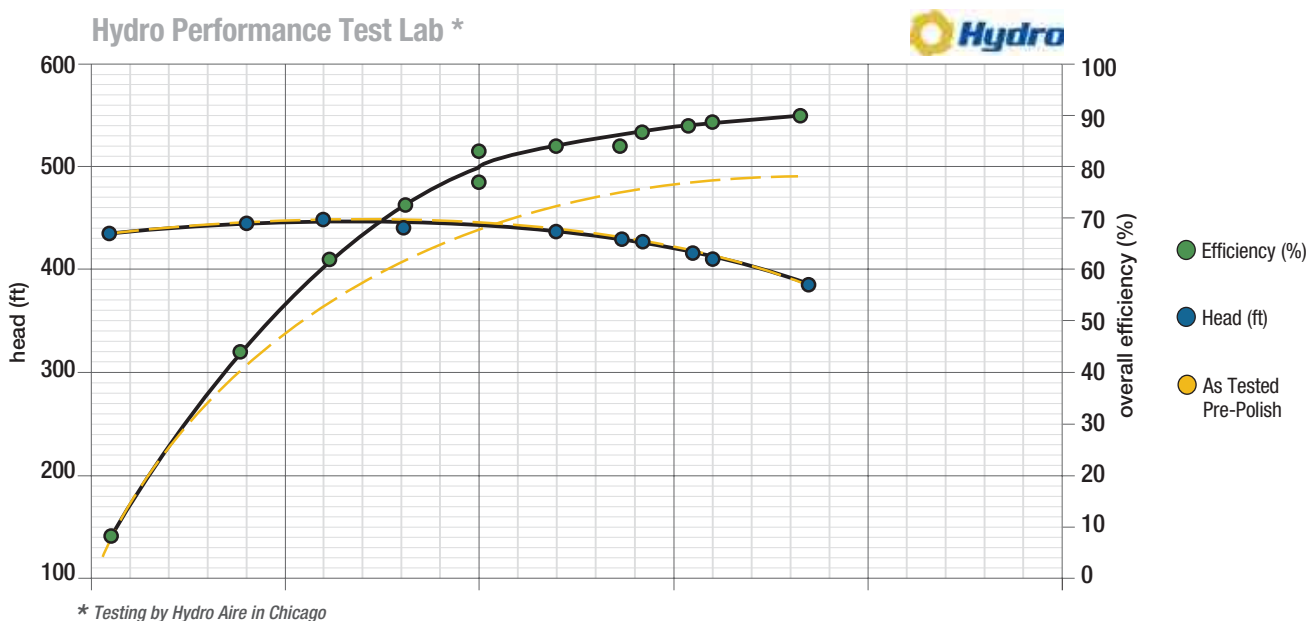



Proven Solutions

The Energy Story

Proving the Pump Efficiency Improvement from the AFM Process

We have selected a 100 hp 1,200 GPM, single impeller overhung process pump as an example to validate the potential efficiency improvement able to be achieved with the AFM process.

- 1) New PACO™ pump purchased, which is about 79% efficient according to the manufacturer's data.
- 2) Pump tested and performance curve generated to confirm initial efficiency pre-AFM. Manufacturer data confirmed by our "before AFM" testing.
- 3) Pump was disassembled and impeller removed to AFM process. Pump was then reassembled.
- 4) Re-tested pump and generated performance curve.

Results: **Peak efficiency gain of +11%**, bringing the pump to 90% total efficiency! Gains were realized over the full usable range of the pump with **significant power savings** at given pressure and flow rate.

Test Component

Pump Type:	ITT Goulds 12BF
Pump Size:	3 x 4-10
Serial No.:	G1162372
Stages:	1
SG:	1.00
NPSHr:	n/a
Speed:	3600 RPM

Hydro Performance Test Lab *

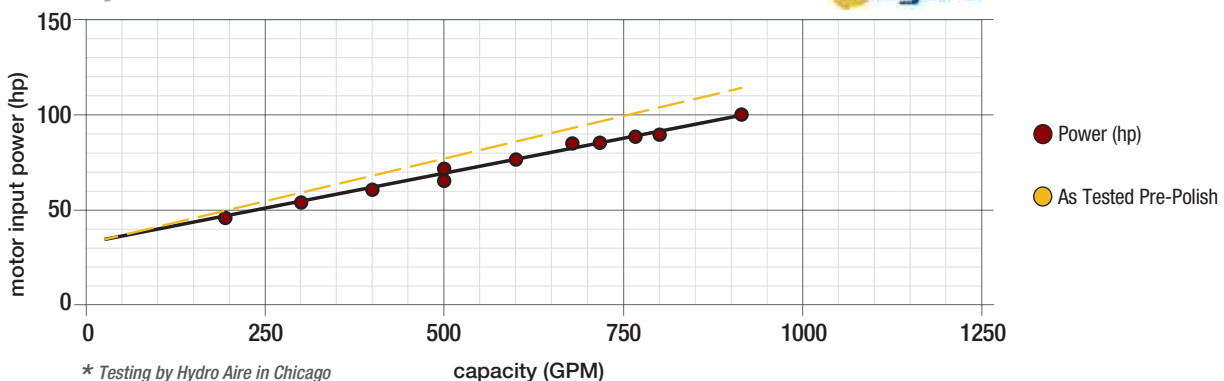

* Testing by Hydro Aire in Chicago

Service and Support

Kennametal ToolBOSS™

Kennametal ToolBOSS™

Secure, High-Capacity Solutions

ToolBOSS™ quickly and consistently delivers quantifiable savings in hundreds of metalworking companies worldwide. Much more than a vending unit, the Kennametal ToolBOSS system is a secure, electronically locked tool storage cabinet that can establish 24-hour tool control for high-value items. It issues tools, returns tools, sends to re-work, supports EDI ordering, and provides for multi-vendor security.

Efficiency

Multiple drawers can be selected in one transaction, minimising the time required to manage large stock volumes.

Future-Port

USB interface, as well as a DCS expansion port, for use with RFID and other ancillary equipment.

High-Speed Access

Rapid search and selection of an item is enhanced with LED identification system, guiding users to the correct drawer.

Traceability

Software provides a complete audit trail, tracking component usage details.

Expandability

Expandable up to 10 units per system, providing up to 1.121 secure locations.



To learn more about ToolBOSS, contact your local
Authorised Distributor or visit www.kennametal.com

Reconditioning Services

Reconditioning Services

Our Reconditioning Services help optimise the total value of your metalcutting tools throughout their entire life cycle by giving the “like-new” performance characteristics — with rapid turnaround time — so the tools you need are always on-hand and perform just like new.



Reduce Tooling Cost by More than 50%

Example: 4" (10,5mm) HP-Drill B225A10500 KC7315 Material: Alloy steel 30 RC

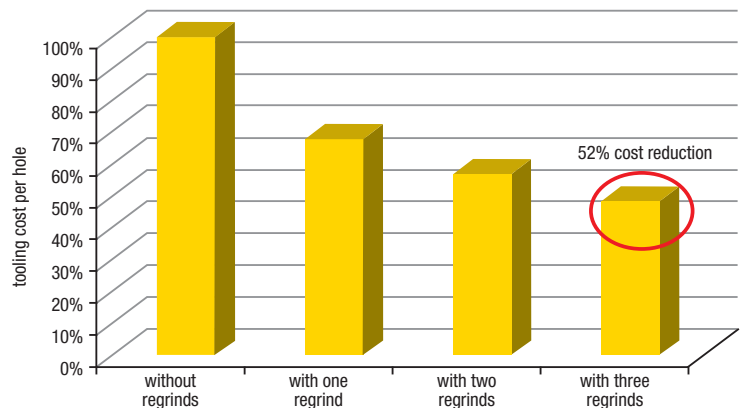

Using Kennametal’s Reconditioning Services provides considerable savings throughout the life of your cutting tools and can reduce your overall tooling costs more than 50%.

For more information or to find the nearest reconditioning location, contact your local Authorised Distributor or visit www.kennametal.com

Service and Support



Carbide Recycling

Help Preserve and Protect Our Planet!

It's easy for your company to be environmentally conscious with the Kennametal Carbide Recycling Program.

By sending us your used carbide tools, you help preserve and protect the environment and ensure that these products are recycled responsibly. Kennametal accepts any coated or non-coated carbide items, including inserts, drills, reamers, and taps.

By using the Kennametal Carbide Recycling Program, you will receive:

- A partner who cares about a sustainable environment.
- Easy-to-use web portal to value your used carbide.
- Access to our popular Green Box™ options for carbide collection.
- Systematic and efficient disposal of carbide materials.
- Improved profitability.

Program is not currently available in all geographical areas. For more information, please visit www.kennametal.com/carbiderecycling



Service and Support

Cost per Part Services Program (CPP)

Build a Long-Term Relationship with the Leader in Metalworking Solutions that Provides:

- Monthly cost savings documented and captured in standardised KPI reports.
- Availability of Kennametal's latest technology to increase productivity and lower cost of operations.
- Onsite technical support available on a constant basis.
- Billing based on the output of your plant that eliminates inventory risk.

YTD Cost Savings Tracker

Site GOAL — \$300,000

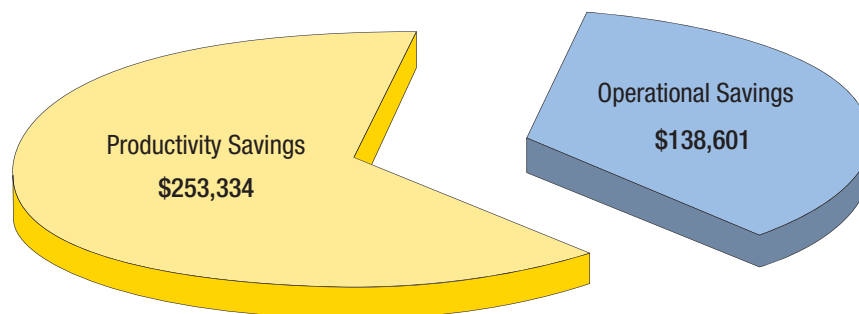

Cost per Part Services Programs Are Designed to Take Advantage of Our Wear Solutions Expertise by Outsourcing Your Metalworking Requirements that:

- Improve productivity.
- Reduce risk.
- Manage inventory.
- Lower operational costs.

For more information, contact your local Authorised Distributor or visit www.kennametal.com

Service and Support

Customer Application Support (CAS)

Customer Application Support

Get Fast and Reliable Answers to Your Toughest Metalcutting Problems

Our Customer Application Support (CAS) Team is the metalworking industry's leading help desk resource for tooling application solutions and problem resolution.

Easy Access to Proven Metalworking Expertise!

Kennametal Customer Application Engineers assist customers and engineering groups throughout the world with expert tool selection and application recommendations for the entire range of Kennametal tooling.

Service Level Excellence

- Fast telephone response.
- Quick technical solutions.
- Efficient case management.

Services

- Operating parameters.
- Process optimisation.
- Hardware support.
- Tooling selection.
- Troubleshooting.

Best-in-Class Support Tools and Technology

- Materials database.
- Application calculators.
- Tooling performance experts.

Convenient Access Options:

Originating Country	Language	Phone	Fax	E-mail
Australia	English	1800 674037	+1-724-539-6830	ap-kmt.techsupport@kennametal.com
Austria	German	0800 202873 *	0800 202874	eu-kmt.techsupport@kennametal.com
Belgium	English/French	0800 80850 *	0800 80868	eu-kmt.techsupport@kennametal.com
China	Chinese	440-889-2238	21-5834-2200	k-cn.techsupport@kennametal.com
Denmark	English	80889298 *	80889296	na-kmt.techsupport@kennametal.com
Finland	English	0800919412 *	0800919414	na-kmt.techsupport@kennametal.com
France	French	0805540367 *	0805540028 *	eu-kmt.techsupport@kennametal.com
Germany	German	0800 0006651 *	0800 0006649	eu-kmt.techsupport@kennametal.com
India	English	+1-724-539-8862	+1-724-539-6830	ap-kmt.techsupport@kennametal.com
Israel	English	1809 449889	1809 449918	na-kmt.techsupport@kennametal.com
Italy	Italian	800 916561 *	800 917505	eu-kmt.techsupport@kennametal.com
Japan	English	0120 225429	+1-724-539-6830	ap-kmt.techsupport@kennametal.com
Korea (South)	English	080 728 0880	+1-724-539-6830	ap-kmt.techsupport@kennametal.com
Malaysia	English	1800 812 990 *	+1-724-539-6830	ap-kmt.techsupport@kennametal.com
Netherlands	English	0800 0201130 *	0800 0201132	eu-kmt.techsupport@kennametal.com
New Zealand	English	0800 450941 *	0800 450921	ap-kmt.techsupport@kennametal.com
Norway	English	80010080 *	80010082	na-kmt.techsupport@kennametal.com
Poland	Polish	00800 4411887 *	00800 4411888	eu-kmt.techsupport@kennametal.com
Singapore	English	1800 6221031	+1-724-539-6830	ap-kmt.techsupport@kennametal.com
South Africa	English	0800 981643 *	+1-724-539-6830	na-kmt.techsupport@kennametal.com
Sweden	English	020799246	020795474	na-kmt.techsupport@kennametal.com
Taiwan	English	0800 666 197 *	+1-724-539-6830	ap-kmt.techsupport@kennametal.com
Thailand	English	1800 4417820 *	+1-724-539-6830	ap-kmt.techsupport@kennametal.com
United Kingdom	English	0800 032 8339 *	0800 028 5803 *	na-kmt.techsupport@kennametal.com
USA	English	800-835-3668 *	724-539-6830	na-kmt.techsupport@kennametal.com

* Toll-free number.

QR Codes

Kennametal QR Codes

Looking for More Products or Product Information?

Use your smartphone or tablet to scan the QR codes throughout this catalogue.

Throughout the Kennametal Innovations Master Catalogue, you will find codes like the shown here that will activate links containing more information about various products and services offered.

The QR codes that you will find within this catalogue are designed to relate to the products or product families on the page where they are found. These codes will link you to expanded product information, such as application videos, informative drawings and animations, extra product charts and graphs, or simply to an expanded online catalogue of products offered by Kennametal for all your drilling, turning, and milling needs.



Helpful Information to Get You Scanning

QR codes are activated when scanned with a dedicated QR scanning application using the onboard camera of your smartphone or tablet.

If you currently have a QR scanner on your smartphone or tablet, look for codes to learn more information about our products. Don't have a QR scanner on your device? It's simple to get one. Just go to your device's application store, and search for a "QR code scanner". Follow your application store's directions on downloading an application, and then launch your QR scanner.

- With your scanner, centre the QR code in the camera window of your application.
- When the scanner locks onto the image, you will be on your way to the embedded information in the QR code.
- Once the webpage, video, or other information linked to the QR code opens or loads, you can freely interact.

When you need information quickly on a product or an extended product catalogue, skip the web search and long website URLs and scan the provided QR codes in this catalogue.

Scan the code at the top of the page to visit our website and online product catalogue.

QR Code is a registered trademark of Denso Wave Incorporated.

Service and Support

Merchandise

Merchandise

New Merchandise Available! Place Your Order Today!

Introducing a new line of Kennametal merchandise. Place an order for any of the following quality products with your Authorised Kennametal Distributor or visit www.kennametal.com.



Solid Performance Polo

100% polyester. No curl/rib-knit jacquard collar. Antimicrobial.

- Colour: charcoal



Windbreaker Jacket

Comfortable fit with a water-repellent shell and mesh lining, lower front pockets for added convenience. 100% polyester. Features elasticised cuffs and an open bottom with a drawstring cord.

- Colour: black



Extreme Colorblock Polo

100% polyester. Moisture wicking, antimicrobial, and raglan sleeves.

- Colour: black/gold



Extreme Cap

Extreme Cap is a classic unstructured cap made of soft laundered cotton for a casual, comfortable feel. Pre-curved visor and six sewn eyelets give this cap the look of a traditional baseball cap. Fabric strap with slide buckle.

- Colour: black and camo



Titleist® DT SoLo® Golf Balls

The new DT SoLo golf ball will appeal to a broad range of golfers seeking the combination of long distance, exceptional feel, responsive short game control, and cut-proof cover durability.

- Colour: white



Hanes® TAGLESS® T-Shirt

100% cotton. Pre-shrunk.

- Colour: black



12 oz. Ceramic Tumbler

Silicone lid. Double-wall ceramic tumbler. 5.5" tall without the lid. Fits in most corporate coffee machines. Includes 1-piece gift box. 11 oz.

- Colour: black with black lid



Majestic Ballpoint Pen

Majestic metal ballpoint pen with chrome trim and coloured centre band.

- Colour: black metal with chrome trim

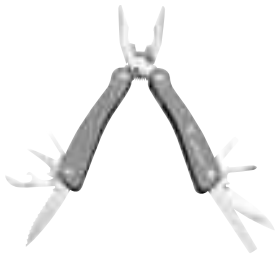

Dakota Multi-Tool

4" closed. Silver anodised aluminium handles. Features spring-action needle nose and regular pliers, serrated knife blade, straight-edge knife blade, can/bottle opener, file, 2 screwdrivers, Phillips head screwdriver, and more. Comes with nylon belt pouch. Boxed.

- Colour: grey



Jupiter Flashlight

Metal, 17" white LED flashlight. Push button power switch. Wrist strap. Three AAA batteries included (not inserted).

- Colour: black



Bottle Opener

Contemporary design, aluminium bottle opener/ key tag. Ergonomic, curved construction improves handling and safely opens metal bottle caps.

- Colour: black



Collapsible Koozie

Fits 16 oz. water bottles and longnecks.

- Colour: black



Notebook Combo

6-1/4" x 8-1/2". Double spiral binding, elastic pen loop on cover. 80 white-lined sheets (non-refillable).

- Colour: yellow



Aluminium Bottle

The ribbed aluminium bottle is BPA free and has a silicone color band with a matching drinking spout and lid.

- Colour: metal/black/yellow

Visit www.kennametal.com to see all available merchandise and for ordering details.



STATIONARY TOOLS



TURNING



Table of Contents

Turning Introduction A0-A3

ISO Inserts B0-B130

PCBN/PCD Inserts B132-B197

O.D./I.D. Toolholders C0-C147

Grooving and Cut-Off D0-D145

Threading E0-E103

Application Specific F0-F131



Turning Products

Our latest Metalcutting Innovations are designed to deliver higher productivity, longer tool life, and increased application versatility.



ISO INSERTS

See Section B for more details.

Carbide Inserts

NEW!

Beyond™ Technology

- PVD Grades KCU10™/KCU25™
- CVD Grades

Ceramic Inserts

NEW!

Beyond Technology

- KYK10 and KYK25 Ceramic Grades for CI
- KYS25 and KYS30 Ceramic Grades for High-Temp

Superhard Inserts

- CBN Inserts with Chipbreaker

Kennametal Select Insert Line

TOOLHOLDERS

See Section C for more details.

Toolholders

- Kenclamp™
- Kenloc™
- Kenlever™
- Kendex™

Boring Bars

- Kenclamp
- Kenloc
- Kenlever
- Kendex



For more information about the latest products and services from Kennametal, please contact your Kennametal Representative or Authorized Kennametal Distributor, or visit www.kennametal.com.



THREADING, GROOVING, AND CUT-OFF (TG&C)

See Sections D and E for more details.

A2™, A3™, and A4™

NEW!

Beyond™ Technology
• KCU25™ PVD Grade

- CBN Inserts
- A4 Clubhead Toolholders

Top Notch™ Grooving and Threading

NEW!

Beyond Technology
• KCU25 PVD Grade

- CBN Inserts

LT Threading



APPLICATION SPECIFIC

See Section F for more details.

Beyond BLAST™

Fix-Perfect™







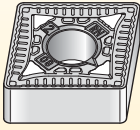
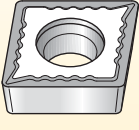
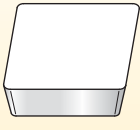
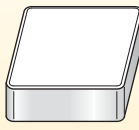

Top Notch Profiling

Tooling for Railroad



■ ISO Turning Inserts



Step 1 • Select Insert Style

				
	Kenloc™	Screw-On	Kendex™ Positive	Kendex Negative
C 	Carbide: B38-B47 Ceramic: B116 Superhard: B172-B174	Carbide: B86-B93 Superhard: B185-B188	Carbide: B82 Superhard: B183	Ceramic: B120 Superhard: B180-B181
D 	Carbide: B47-B56 Ceramic: B117 Superhard: B174-B176	Carbide: B93-B98 Superhard: B189-B192	—	Ceramic: B121 Superhard: B181
R 	Carbide: B56-B57 Ceramic: B117	Carbide: B98-B100	Carbide: B82-B83 Ceramic: B126-B127	Ceramic: B122 Superhard: B180
S 	Carbide: B57-B64 Ceramic: B118 Superhard: B176-B177	Carbide: B101-B104	Carbide: B83-B84 Ceramic: B127-B128	Ceramic: B123-B124 Superhard: B180, B182
T 	Carbide: B64-B71 Ceramic: B118 Superhard: B177-B179	Carbide: B104-B110 Superhard: B192-B194	Carbide: B84-B85 Ceramic: B128 Superhard: B183-B184	Ceramic: B124 Superhard: B182
V 	Carbide: B72-B76 Ceramic: B118 Superhard: B178-B179	Carbide: B111-B112 Superhard: B194-B195	—	Ceramic: B124
W 	Carbide: B76-B81 Ceramic: B119 Superhard: B179	Carbide: B112-B113	—	Ceramic: B125

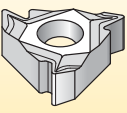
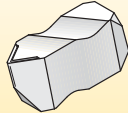
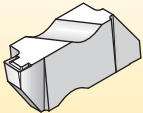
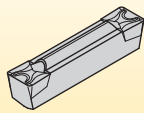
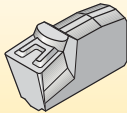
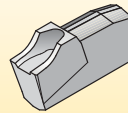
■ Threading, Grooving, and Cut-Off

						
	LT	Top Notch™ Threading	Top Notch Grooving	A4™	A3™	A2™
inserts	E40-E64	E8-E21	D116-D131	D68-D79	D30-D33	D12-D16
toolholders	E66-E71	E22-E34	D132-D139	D80-D107	D34-D57	D18-D24

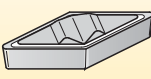
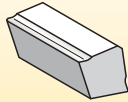
■ Application Specific

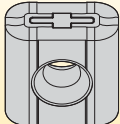
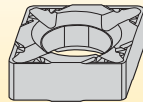
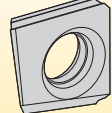
						
	Top Notch Profiling	Kendex Mini	K-Lock™	Railroad/Bar Peeling	Beyond BLAST™	Fix-Perfect™
inserts	F39-F44	F63	F59	F80-F83, F91-F93, F103-F105	F6-F9	F14-F28
toolholders	F45-F46	F64-F65	F60-F61	F68-F79, F85-F90, F95-F102	F10-F11	F30-F37

Step 2 • Select Application and Clamping System

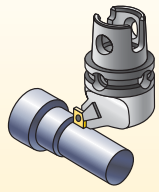

External
Machining

			Kenclamp™	Kenloc™	Kenlever™	Kendex™ Negative	Screw-On	Kendex Positive
C		conventional	C6-C8	C24-C26	C15-C17	C36	C42-C47	-
D		conventional	C8-C9	C26-C27	C183	-	C47-C49	-
R		conventional	C9	C27	-	-	C50-C51	-
S		conventional	C10-C12	C28-C30	C19-C20	C36-C37	C51-C53	C38-C39
T		conventional	C12-C13	C30-C32	C21	-	C53-C54	C40
V		conventional	C13-C14	C32-C33	-	-	C55-C57	-
W		conventional	C14-C15	C33	C22	C37	C57	-

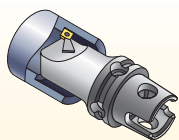

Internal
Machining

			Kenclamp	Kenloc	Kenlever	Kendex Negative	Screw-On	Kendex Positive
C		conventional	C78	C82	C105	C107	C87-C94	-
D		conventional	C78-C79	C82	-	C107-C108	C94-C97	-
R		conventional	-	-	-	-	-	-
S		conventional	C80	C83	C105	C108-C109	C97-C98	C85
T		conventional	C80	C83	C106	-	C98-C102	C85-C86
V		conventional	C81	C83	-	-	C102-C103	-
W		conventional	C81	C84	C106	C109	C103-C104	-

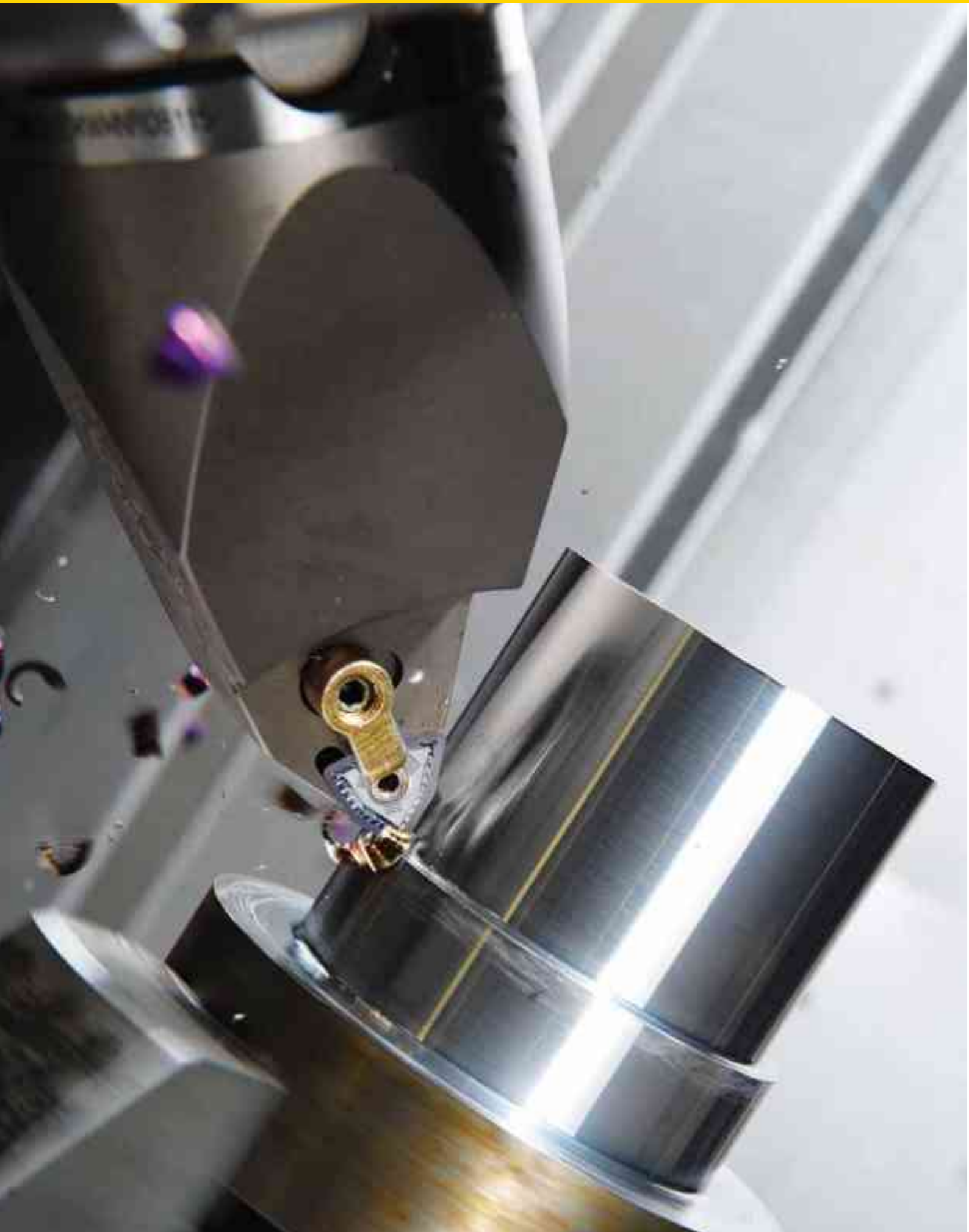

ISO Inserts

Kennametal InsertsB2-B23
Grades and Grade DescriptionsB24-B31
Chip Control GeometriesB32-B37
ISO Carbide InsertsB38-B115
ISO Ceramic InsertsB116-B130
Superhard Materials • PCBN/PCD InsertsB133-B197





Inserts for Every Turning Operation



Kennametal, the trusted innovator in metalcutting technology, offers a complete range of indexable inserts for general turning operations. From roughing to finishing, Kennametal has the correct insert.

Plus, Kennametal offers the next generation in tooling with Beyond™. Harnessing advanced science and exceptional experience, our Beyond inserts deliver unparalleled levels of productivity, efficiency, dependability, and profitability.

Features and Benefits

Up to 30% Higher Productivity and Profitability

- Achieve higher metal removal rates (speed, feed, and depth of cut).
- Gain longer tool life.

Versatility

- Products can be applied across a wide range of applications.
- Can be used in low- to high-speed applications.

Reliability

- Deliver uniform wear for predictable tool life.
- Achieve reduced depth-of-cut notching.
- Virtually eliminate chip flow damage.

Complete Portfolio

- The Beyond product portfolio can be used in a complete range of steel, cast iron, and stainless steel ISO turning workpieces.

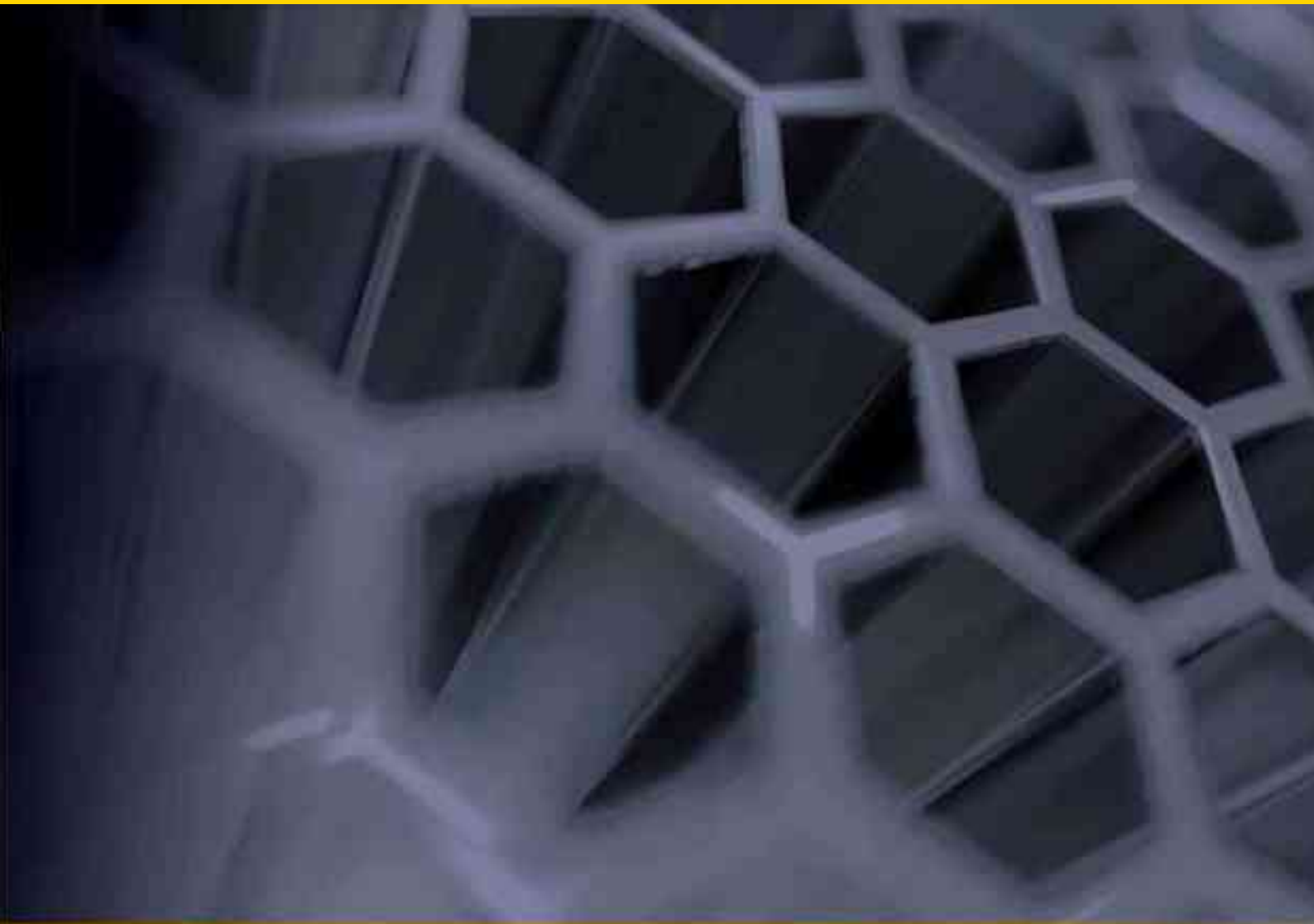

Technical Details • Features

Post-Coat Treatment

- Improves edge toughness.
- Long predictable tool life.
- Reduces depth-of-cut notching.
- Wide range of applications.
- Reduces stresses.
- Reduces microchipping.
- Improves coating adhesion.

Fine-Grained Alumina Layer

- Provides coating integrity at elevated speeds.
- Higher productivity and dependability at high cutting temperatures.

Micro-Polished Edges

- Improves edge toughness.
- Provides smooth outer surface to reduce forces, friction, and workpiece sticking.

Post-Coat Grinding — Bottom

- Provides secure seating surface.

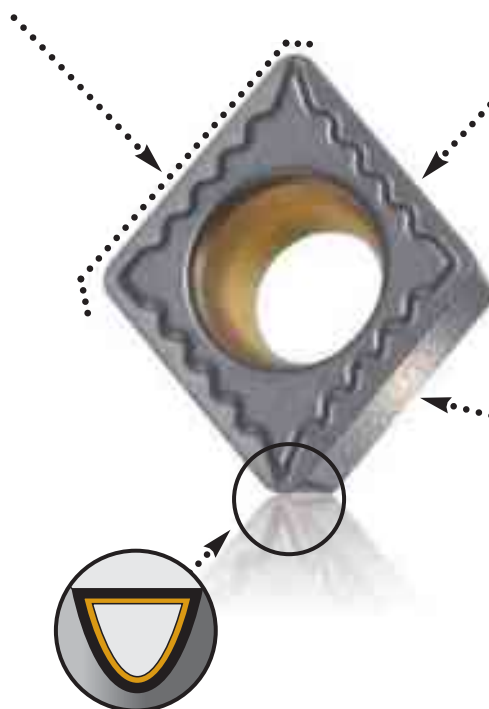

How Do Catalogue Numbers Work?

Each character in our catalogue number signifies a specific trait of that product. Use the following key columns and corresponding images to easily identify which attributes apply.

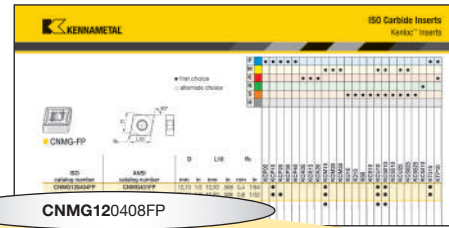

CNMG120408FP

C		N		M		G		12																																																																																																																																																																																																																															
Insert Shape		Insert Clearance Angle		Tolerance Class		Insert Features		Size																																																																																																																																																																																																																															
H	Hexagon 120°	A	3°	<p>Tolerances apply prior to edge prep and coating</p> <p>D = Theoretical diameter of the insert inscribed circle S = Thickness B = See figures below</p>	N		<p>Code for inch cutting edge length "L10"</p> <table border="1"> <thead> <tr> <th rowspan="2">inch</th> <th rowspan="2">mm</th> <th colspan="8">"D"</th> </tr> <tr> <th>C</th> <th>D</th> <th>R</th> <th>S</th> <th>T</th> <th>V</th> <th>W</th> </tr> </thead> <tbody> <tr> <td>1.2 (5)</td> <td>3,97</td> <td>S4</td> <td>04</td> <td>03</td> <td>03</td> <td>06</td> <td>—</td> <td>—</td> </tr> <tr> <td>1.5 (6)</td> <td>4,76</td> <td>04</td> <td>05</td> <td>04</td> <td>04</td> <td>08</td> <td>S3</td> <td>—</td> </tr> <tr> <td>1.8 (7)</td> <td>5,56</td> <td>05</td> <td>06</td> <td>05</td> <td>05</td> <td>09</td> <td>09</td> <td>03</td> </tr> <tr> <td>—</td> <td>6,00</td> <td>—</td> <td>—</td> <td>06</td> <td>—</td> <td>—</td> <td>—</td> <td>—</td> </tr> <tr> <td>2</td> <td>6,35</td> <td>06</td> <td>07</td> <td>06</td> <td>06</td> <td>11</td> <td>11</td> <td>04</td> </tr> <tr> <td>2.5</td> <td>7,94</td> <td>08</td> <td>09</td> <td>07</td> <td>07</td> <td>13</td> <td>13</td> <td>05</td> </tr> <tr> <td>—</td> <td>8,00</td> <td>—</td> <td>—</td> <td>08</td> <td>—</td> <td>—</td> <td>—</td> <td>—</td> </tr> <tr> <td>3</td> <td>9,52</td> <td>09</td> <td>11</td> <td>09</td> <td>09</td> <td>16</td> <td>16</td> <td>06</td> </tr> <tr> <td>—</td> <td>10,00</td> <td>—</td> <td>—</td> <td>10</td> <td>—</td> <td>—</td> <td>—</td> <td>—</td> </tr> <tr> <td>3.5</td> <td>11,11</td> <td>11</td> <td>13</td> <td>11</td> <td>11</td> <td>19</td> <td>19</td> <td>07</td> </tr> <tr> <td>—</td> <td>12,00</td> <td>—</td> <td>—</td> <td>12</td> <td>—</td> <td>—</td> <td>—</td> <td>—</td> </tr> <tr> <td>4</td> <td>12,70</td> <td>12</td> <td>15</td> <td>12</td> <td>12</td> <td>22</td> <td>22</td> <td>08</td> </tr> <tr> <td>4.5</td> <td>14,29</td> <td>14</td> <td>17</td> <td>14</td> <td>14</td> <td>24</td> <td>24</td> <td>09</td> </tr> <tr> <td>5</td> <td>15,88</td> <td>16</td> <td>19</td> <td>15</td> <td>15</td> <td>27</td> <td>27</td> <td>10</td> </tr> <tr> <td>—</td> <td>16,00</td> <td>—</td> <td>—</td> <td>16</td> <td>—</td> <td>—</td> <td>—</td> <td>—</td> </tr> <tr> <td>5.5</td> <td>17,46</td> <td>17</td> <td>21</td> <td>17</td> <td>17</td> <td>30</td> <td>30</td> <td>11</td> </tr> <tr> <td>6</td> <td>19,05</td> <td>19</td> <td>23</td> <td>19</td> <td>19</td> <td>33</td> <td>33</td> <td>13</td> </tr> <tr> <td>—</td> <td>20,00</td> <td>—</td> <td>—</td> <td>20</td> <td>—</td> <td>—</td> <td>—</td> <td>—</td> </tr> <tr> <td>7</td> <td>22,22</td> <td>22</td> <td>27</td> <td>22</td> <td>22</td> <td>38</td> <td>38</td> <td>15</td> </tr> <tr> <td>—</td> <td>25,00</td> <td>—</td> <td>—</td> <td>25</td> <td>—</td> <td>—</td> <td>—</td> <td>—</td> </tr> <tr> <td>8</td> <td>25,40</td> <td>25</td> <td>31</td> <td>25</td> <td>25</td> <td>44</td> <td>44</td> <td>17</td> </tr> <tr> <td>10</td> <td>31,75</td> <td>32</td> <td>38</td> <td>31</td> <td>31</td> <td>54</td> <td>54</td> <td>21</td> </tr> <tr> <td>—</td> <td>32,00</td> <td>—</td> <td>—</td> <td>32</td> <td>—</td> <td>—</td> <td>—</td> <td>—</td> </tr> </tbody> </table>	inch	mm	"D"								C	D	R	S	T	V	W	1.2 (5)	3,97	S4	04	03	03	06	—	—	1.5 (6)	4,76	04	05	04	04	08	S3	—	1.8 (7)	5,56	05	06	05	05	09	09	03	—	6,00	—	—	06	—	—	—	—	2	6,35	06	07	06	06	11	11	04	2.5	7,94	08	09	07	07	13	13	05	—	8,00	—	—	08	—	—	—	—	3	9,52	09	11	09	09	16	16	06	—	10,00	—	—	10	—	—	—	—	3.5	11,11	11	13	11	11	19	19	07	—	12,00	—	—	12	—	—	—	—	4	12,70	12	15	12	12	22	22	08	4.5	14,29	14	17	14	14	24	24	09	5	15,88	16	19	15	15	27	27	10	—	16,00	—	—	16	—	—	—	—	5.5	17,46	17	21	17	17	30	30	11	6	19,05	19	23	19	19	33	33	13	—	20,00	—	—	20	—	—	—	—	7	22,22	22	27	22	22	38	38	15	—	25,00	—	—	25	—	—	—	—	8	25,40	25	31	25	25	44	44	17	10	31,75	32	38	31	31	54	54	21	—	32,00	—	—	32	—	—	—	—
inch	mm	"D"																																																																																																																																																																																																																																					
		C	D		R	S		T	V	W																																																																																																																																																																																																																													
1.2 (5)	3,97	S4	04		03	03		06	—	—																																																																																																																																																																																																																													
1.5 (6)	4,76	04	05		04	04		08	S3	—																																																																																																																																																																																																																													
1.8 (7)	5,56	05	06		05	05		09	09	03																																																																																																																																																																																																																													
—	6,00	—	—		06	—		—	—	—																																																																																																																																																																																																																													
2	6,35	06	07		06	06		11	11	04																																																																																																																																																																																																																													
2.5	7,94	08	09		07	07		13	13	05																																																																																																																																																																																																																													
—	8,00	—	—		08	—		—	—	—																																																																																																																																																																																																																													
3	9,52	09	11	09	09	16	16	06																																																																																																																																																																																																																															
—	10,00	—	—	10	—	—	—	—																																																																																																																																																																																																																															
3.5	11,11	11	13	11	11	19	19	07																																																																																																																																																																																																																															
—	12,00	—	—	12	—	—	—	—																																																																																																																																																																																																																															
4	12,70	12	15	12	12	22	22	08																																																																																																																																																																																																																															
4.5	14,29	14	17	14	14	24	24	09																																																																																																																																																																																																																															
5	15,88	16	19	15	15	27	27	10																																																																																																																																																																																																																															
—	16,00	—	—	16	—	—	—	—																																																																																																																																																																																																																															
5.5	17,46	17	21	17	17	30	30	11																																																																																																																																																																																																																															
6	19,05	19	23	19	19	33	33	13																																																																																																																																																																																																																															
—	20,00	—	—	20	—	—	—	—																																																																																																																																																																																																																															
7	22,22	22	27	22	22	38	38	15																																																																																																																																																																																																																															
—	25,00	—	—	25	—	—	—	—																																																																																																																																																																																																																															
8	25,40	25	31	25	25	44	44	17																																																																																																																																																																																																																															
10	31,75	32	38	31	31	54	54	21																																																																																																																																																																																																																															
—	32,00	—	—	32	—	—	—	—																																																																																																																																																																																																																															
O	Octagon 135°	B	5°	R																																																																																																																																																																																																																																			
P	Pentagon 108°	C	7°	F																																																																																																																																																																																																																																			
R	Round —	D	15°	A																																																																																																																																																																																																																																			
S	Square 90°	E	20°	M																																																																																																																																																																																																																																			
T	Triangular 60°	F	25°	G																																																																																																																																																																																																																																			
C	Rhomboid 80° 55° 75° 86° 35°	G	30°	W																																																																																																																																																																																																																																			
D		N	0°	T																																																																																																																																																																																																																																			
E		P	11°	Q																																																																																																																																																																																																																																			
M		O	Indicated for other clearance angles requiring descriptions.	U																																																																																																																																																																																																																																			
V		L	Rectangular 90°	J																																																																																																																																																																																																																																			
W	Trigon 80° with enlarged corner angles	A	85°	X	Special Design																																																																																																																																																																																																																																		
L	Rectangular 90°	B	82°																																																																																																																																																																																																																																				
A	Parallelogram 85°	N/K	55°																																																																																																																																																																																																																																				

tolerance class	tolerance on "D"	tolerance on "B"	tolerance on "S"
C	±0,025	±0,013	±0,025
H	±0,013	±0,013	±0,025
E	±0,025	±0,025	±0,025
G	±0,025	±0,025	±0,013
M	See tables on next page		±0,013
U	See tables on next page		±0,013

By referencing this easy-to-use guide, you can identify the correct product to meet your needs.

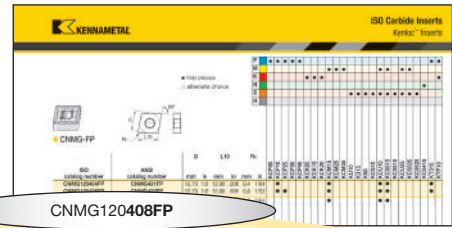

CNMG120408FP

04

Thickness
S

symbol	thickness
mm	mm
—	0,79
T0	1,00
01	1,59
T1	1,98
02	2,38
03	3,18
T3	3,97
04	4,76
05	5,56
06	6,35
07	7,94
9	9,52
11	11,11
12	12,70

08

Corner
Radius "R_c"

symbol	corner radius
mm	mm
X0	0,04
01	0,1
02	0,2
04	0,4
08	0,8
12	1,2
16	1,6
20	2,0
24	2,4
28	2,8
32	3,2
00	round insert
M0	
—	

Hand of Insert
(optional)

R = Right hand

L = Left hand

N = Neutral

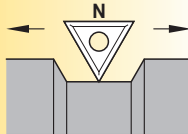
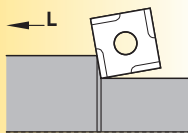
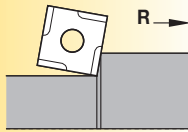

Cutting Edge
(optional)

- F Sharp
- E Rounded
- T Chamfered
- S Chamfered and Rounded
- K Double-Chamfered
- P Double-Chamfered and Rounded

FP

Chipbreaker
(optional)

- F = Sharp
- FF = Fine Finishing
- FN = Finishing Negative
- MN = Medium Negative
- RN = Roughing Negative
- UN = Universal Medium
- FP = Finishing Positive
- MP = Medium Positive
- RP = Roughing Positive
- RM = Roughing Medium
- RH = Roughing Heavy
- FW = Finishing Wiper
- MW = Medium Wiper
- FS = Finishing Sharp
- MS = Medium Sharp
- RW = Roughing Wiper
- HP = High Positive
- UP = Universal Positive
- K = Light-Feed Chip Control
- UF = Ultra-Fine Finishing
- LF = Light Finishing
- MF = Medium Finishing
- E = Hone Only
- T = Negative Land
- S = Negative Land Plus Hone
- MP-K = Medium Positive
- MG-P = Medium Positive

"D"	± Tolerance on "D"				"D"	± Tolerance on "B"			
	Class M Tolerance			Class U Tolerance		Class M Tolerance			Class U Tolerance
	Shapes S, T, C, R, & W	Shape D	Shape V	Shapes S, T, & C		Shapes S, T, C, R, & W	Shape D	Shape V	Shapes S, T, & C
mm	mm	mm	mm	mm	mm	mm	mm	mm	
3,97	0,05	—	—	—	3,97	0,08	—	—	—
4,76	0,05	—	—	0,08	4,76	0,08	—	—	0,13
5,56	0,05	0,05	0,05	0,08	5,56	0,08	0,11	—	0,13
6,35	0,05	0,05	0,05	0,08	6,35	0,08	0,11	—	0,13
7,94	0,05	0,05	0,05	0,08	7,94	0,08	0,11	—	0,13
9,52	0,05	0,05	0,05	0,08	9,52	0,08	0,11	0,18	0,13
11,11	0,08	0,08	0,08	0,13	11,11	0,13	0,15	—	—
12,70	0,08	0,08	0,08	0,13	12,70	0,13	0,15	0,25	0,20
14,29	0,08	0,08	0,08	0,13	14,29	0,13	0,15	—	—
15,88	0,10	0,10	0,10	0,18	15,88	0,15	0,18	—	0,27
17,46	0,10	0,10	0,10	0,18	17,46	0,15	0,18	—	0,27
19,05	0,10	0,10	0,10	0,18	19,05	0,15	0,18	—	0,27
22,22	0,13	—	—	0,25	22,22	0,15	—	—	0,38
25,40	0,13	—	—	0,25	25,40	0,18	—	—	0,38
31,75	0,15	—	—	0,25	31,75	0,20	—	—	0,38

A system of grades, geometries, and application guidelines to provide optimal solutions for your metalcutting needs. It's easy to determine which Kennametal chip-control cutting tool will work best in your specific workpiece materials and applications!

■ **Grade • Beyond™**



K Brand	C Insert Material	P Primary Workpiece Material (ISO 513)	M Secondary Workpiece Material (optional)	25 Application Range	A Future Upgrades (optional)														
<p>K = Kennametal</p>	<p>Blank = Carbide, uncoated</p> <p>C = Carbide, coated</p> <p>T = Cermet</p> <p>Y = Ceramic</p> <p>D = PCD</p> <p>B = PCBN</p> <p>S = Steel</p>	<table border="1"> <tr><td>P</td><td>Steel</td></tr> <tr><td>M</td><td>Stainless Steel</td></tr> <tr><td>K</td><td>Cast Iron</td></tr> <tr><td>N</td><td>Non-Ferrous Materials</td></tr> <tr><td>S</td><td>High-Temp Alloys</td></tr> <tr><td>H</td><td>Hardened Materials</td></tr> <tr><td>U</td><td>Universal Machining</td></tr> </table>		P	Steel	M	Stainless Steel	K	Cast Iron	N	Non-Ferrous Materials	S	High-Temp Alloys	H	Hardened Materials	U	Universal Machining	<p>Hardest</p> <p>↑</p> <p>5 fine finishing</p> <p>10 finishing</p> <p>15 medium to roughing</p> <p>20</p> <p>25</p> <p>30 roughing</p> <p>35</p> <p>40</p> <p>45 heaviest roughing</p> <p>50</p> <p>↓</p> <p>Toughest</p>	<p>A = Generation 1</p> <p>B = Generation 2</p> <p>C = Generation 3</p> <p>etc.</p>
P	Steel																		
M	Stainless Steel																		
K	Cast Iron																		
N	Non-Ferrous Materials																		
S	High-Temp Alloys																		
H	Hardened Materials																		
U	Universal Machining																		

NOTE: Application range does not apply to PCBN grades.

■ **Grade • Kenna Perfect™**

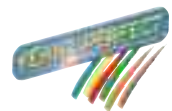

K	C	9 Coating Type	2 Material Group	25 Wear Application Range/Toughness Range																					
		<p>9 = CVD (Chemical Vapor Deposition)</p> <p>5 = PVD (Physical Vapor Deposition)</p>	<table border="1"> <tr><td>1</td><td>P</td><td>Steel</td></tr> <tr><td>2</td><td>M</td><td>Stainless Steel</td></tr> <tr><td>3</td><td>K</td><td>Cast Iron</td></tr> <tr><td>4</td><td>N</td><td>Non-Ferrous Materials</td></tr> <tr><td>5</td><td>S</td><td>High-Temp Alloys</td></tr> <tr><td>6</td><td>H</td><td>Hardened Materials</td></tr> <tr><td>0</td><td></td><td>Universal Machining</td></tr> </table>	1	P	Steel	2	M	Stainless Steel	3	K	Cast Iron	4	N	Non-Ferrous Materials	5	S	High-Temp Alloys	6	H	Hardened Materials	0		Universal Machining	<p>Hardest</p> <p>↑</p> <p>10 highly wear resistant</p> <p>to</p> <p>50 extremely tough</p> <p>↓</p> <p>Toughest</p>
1	P	Steel																							
2	M	Stainless Steel																							
3	K	Cast Iron																							
4	N	Non-Ferrous Materials																							
5	S	High-Temp Alloys																							
6	H	Hardened Materials																							
0		Universal Machining																							

NOTE: Application range does not apply to PCBN grades.

Positive Inserts

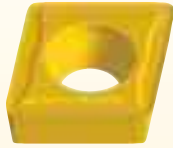

Screw-On Inserts

- Screw-On inserts are your first choice for I.D. turning of all materials and O.D. turning on small to medium lathes.
- Available in flat-top and chip-control geometries with both moulded and ground peripheries. Suitable for all workpiece materials.

See pages:
Carbide: B88–B115
Superhard: B187–B197



Kendex™ and V-Bottom Inserts

- Kendex positive and V-bottom inserts are your first choice for productive machining of high-temperature alloys on medium to large lathes.
- Available in flat-top geometries with ground periphery.

See pages:
Carbide: B84–B87
Ceramic: B128–B130
Superhard: B185–B186

See pages B128–B129 for V-bottom product listing.



Top Notch™ Profiling Inserts

- First choice for high-production profiling.
- Unique insert clamping design offers superior rigidity.
- Available in chip-control geometries with both moulded and ground peripheries. Suitable for all workpiece materials.

See pages F39–F44 for product listing.



K-Lock™ Inserts

- K-Lock inserts are ideal for deep grooving and profiling.
- A unique insert clamping system allows for unimpeded chip flow.
- Available in moulded and ground peripheries.

See page F59 for product listing.

Negative Inserts



Kenloc™ Inserts

- Kenloc inserts are your first choice for general machining of all materials on medium to large lathes.
- Kenloc inserts offer the best economy for high metal removal rates.
- Available in flat-top and chip-control geometries with both moulded and ground peripheries. Suitable for all workpiece materials.

See pages:
Carbide: B40–B83
Ceramic: B118–B121
Superhard: B187–B197



Kendex Inserts

- Ceramic Kendex inserts are a great choice for productive machining of high-temp alloys.
- Kendex negative rake inserts are also recommended for the machining of hardened materials and cast irons.
- Available in flat-top geometries with moulded and ground peripheries.
- Wide selection of standard toolholders are offered.

See pages B122–B127 for product listing.



Top Notch Turning Inserts

- Ceramic Top Notch Turning inserts are your first choice for high-speed roughing and finishing of cast iron parts.
- Available in flat-top geometries with moulded and ground peripheries.

See pages B122–B127 for product listing.

Insert Selection System

How to Use

Kennametal's three-step insert selection system makes choosing and applying the most productive tool as easy as 1, 2, 3. Tool recommendations are based on six workpiece material groups, optimising selection accuracy.

Example: Six workpiece material groups

■ Step 1 • Select the insert geometry

Given: depths of cut = 1mm
feed = 0,4mm

Unknown: insert geometry

Solution: -MN

■ Step 2 • Select the grade

Given: cutting conditions:
lightly interrupted cut

Geometry: -MN

Unknown: grade

Solution: KCP25

■ Step 3 • Select the cutting speed

Given: grade KCP25
cutting conditions
material CK15

Unknown: cutting speed

Solution: 280 m/min

Need help in selecting a product?
Additional information can be obtained by contacting
Kennametal's Customer Application Support Team.
Go to www.kennametal.com for your country's phone number.

Step 1 • Select the insert geometry

Negative Inserts

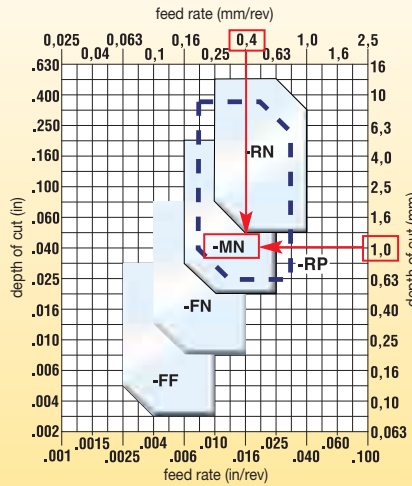
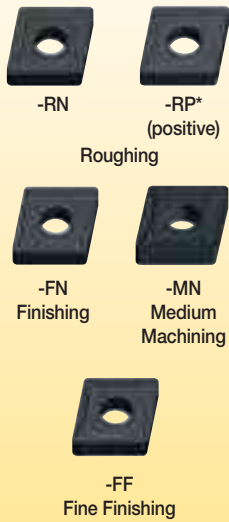

*-RP – Supplemental geometry for high-strength materials

P	Steel
M	Stainless Steel
K	Cast Iron
N	Non-Ferrous Materials
S	High-Temp Alloys
H	Hardened Materials



Step 2 • Select the grade

cutting condition	-FF	-FN	-MN	-RN	-RP	-11	-UF	-LF	-FP	-MF	-MP
heavily interrupted cut	KCP10	KCP25	KCP30	KCP30/KCP40	KCP30/KCP40	—	KC5010/KCP25	KCP25	KCU25/KCP25	KCP40	KCM25
lightly interrupted cut	KCP10	KCP25	KCP25	KCP30/KCP40	KCP30/KCP40	—	KC5010/KCP25	KCP25	KCP25	KCP25	KCP25
varying depth of cut, casting, or forging skin	KCP05/KT315	KCP10	KCP10	KCP30/KCP40	KCP30/KCP40	KT315	KCP10	KCP10	KCP10	KCP10	KCP10

Step 3 • Selecting the cutting speed

Low-Carbon (<0,3% C) and Free-Machining Steel		speed — m/min (SFM)									starting conditions	
material group	grade	135 (450)	180 (600)	225 (800)	275 (900)	320 (1050)	360 (1200)	410 (1350)	455 (1500)	495 (1650)	m/min	SFM
P1	KCP05/KTP10										435	1450
	KCP10										395	1320
	KCP25										275	925
	KCP30/KCP40										210	700

New Beyond™ Material Group Selection Guide:

To optimise speed recommendations, Beyond material subgroups have been added to each of the six workpiece material groups.

material	material group ISO code	number of material subgroups
steel	P	1-6
stainless steel	M	1-3
cast iron	K	1-3
non-ferrous materials	N	1-8
high-temp alloys	S	1-4
hardened materials	H	1

Step 1 • Select the insert geometry

Negative Wiper Inserts

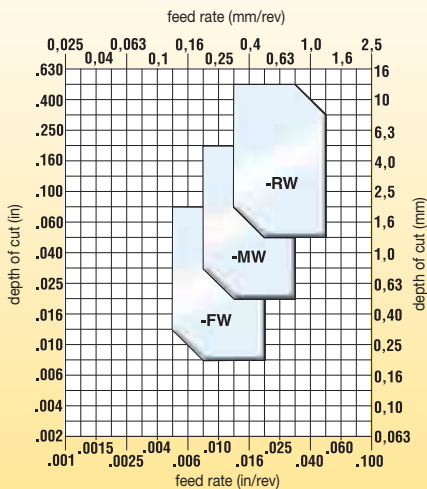

Positive Wiper Inserts

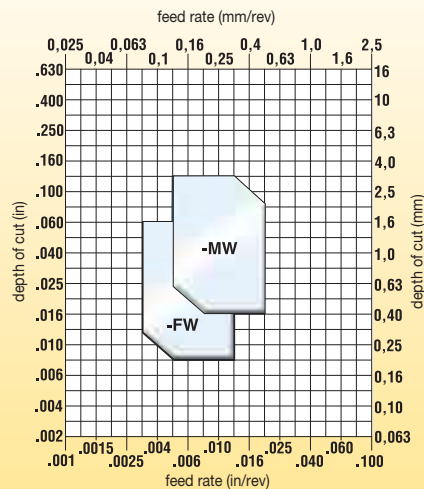

Step 2 • Select the grade

cutting condition	Negative Insert Geometry			Positive Insert Geometry	
	-FW	-MW	-RW	-FW	-MW
heavily interrupted cut	⚙️	-	KCP25	-	KCP25
lightly interrupted cut	⦿	KCP10	KCP25	KCP25	KCP25
varying depth of cut, casting, or forging skin	⦿	KCP05/KT315	KCP10	KCP10/KCK20	KCP10/KCK20
smooth cut, pre-turned surface	⦿	KCP05/KT315	KCP05	KCP10/KT315	KT315/KT315

Step 1 • Select the insert geometry

Negative Inserts

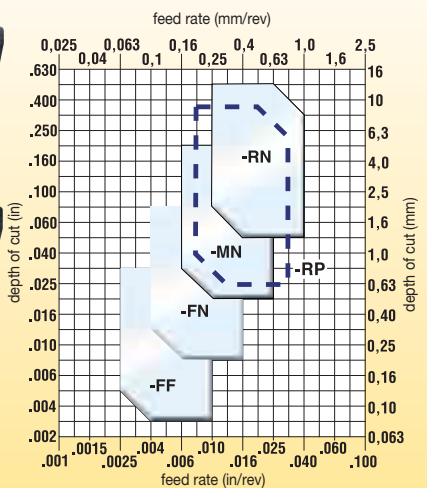
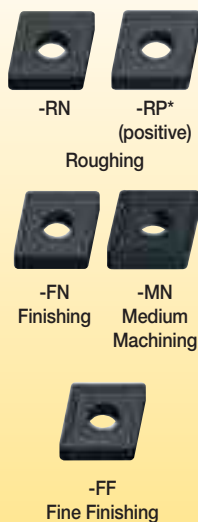

Positive Inserts

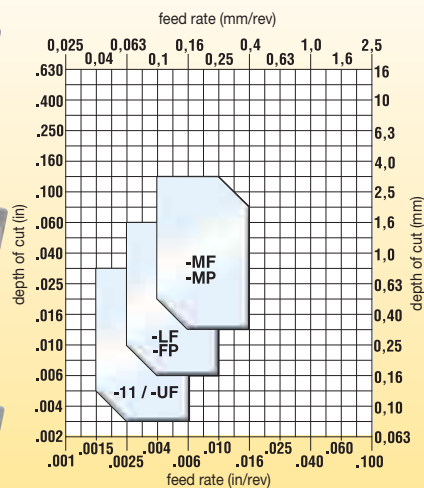
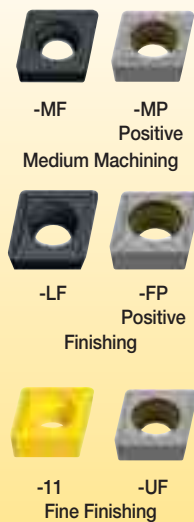

*-RP – Supplemental geometry for high-strength materials

Step 2 • Select the grade

cutting condition	-FF	-FN	-MN	-RN	-RP	-11	-UF	-LF	-FP	-MF	-MP
heavily interrupted cut	⚙️	KCP10	KCP25	KCP30	KCP30/KCP40	—	KC5010/KCP25	KCP25	KCU25/KCP25	KCP40	KCM25
lightly interrupted cut	⦿	KCP10	KCP25	KCP25	KCP30/KCP40	—	KC5010/KCP25	KCP25	KCP25	KCP25	KCP25
varying depth of cut, casting, or forging skin	⦿	KCP05/KT315	KCP10	KCP10	KCP30/KCP40	KT315	KCP10	KCP10	KCP10	KCP10	KCP10
smooth cut, pre-turned surface	⦿	KCP05/KT315	KCP05	KCP05	KCP30/KCP40	KT315	KCP05	KCP05/KT315	KCP05/KTP10	KCP05	KCP05

■ Step 3 • Select the cutting speed
Low-Carbon (<0,3% C) and Free-Machining Steel

material group	grade	speed — m/min (SFM)									starting conditions		
		135 (450)	180 (600)	225 (800)	275 (900)	320 (1050)	360 (1200)	410 (1350)	455 (1500)	495 (1650)	m/min	SFM	
P0/P1	KCP05/KTP10											435	1450
	KCP10											395	1320
	KCP25											275	925
	KCP30/KCP40											210	700
	KT315											440	1450
	KCU10/KC5010											280	925

Medium- and High-Carbon Steels (>0,3% C)

material group	grade	speed — m/min (SFM)									starting conditions		
		135 (450)	180 (600)	225 (800)	275 (900)	320 (1050)	360 (1200)	410 (1350)	455 (1500)	495 (1650)	m/min	SFM	
P2	KCP05/KTP10											240	800
	KCP10											265	880
	KCP25											195	650
	KCP30/KCP40											150	500
	KT315											270	880
	KCU10/KC5010											200	650

Alloy Steels and Tool Steels (≤330 HB) (≤35 HRC)

material group	grade	speed — m/min (SFM)									starting conditions		
		135 (450)	180 (600)	225 (800)	275 (900)	320 (1050)	360 (1200)	410 (1350)	455 (1500)	495 (1650)	m/min	SFM	
P3	KCP05/KTP10											205	680
	KCP10											190	630
	KCP25											155	510
	KCP30/KCP40											120	400
	KT315											210	680
	KCU10/KC5010											155	510

Alloy Steels and Tool Steels (340–450 HB) (36–48 HRC)

material group	grade	speed — m/min (SFM)									starting conditions		
		60 (200)	90 (300)	120 (400)	150 (500)	180 (600)	210 (700)	240 (800)	270 (900)	300 (1000)	m/min	SFM	
P4	KCP05/KTP10											160	530
	KCP10											145	480
	KCP25											105	360
	KCP30/KCP40											95	325
	KT315											210	530
	KCU10/KC5010											110	360

Ferritic, Martensitic, and PH Stainless Steels (≤330 HB) (≤35 HRC)

material group	grade	speed — m/min (SFM)									starting conditions		
		120 (400)	150 (500)	180 (600)	210 (700)	240 (800)	270 (900)	300 (1000)	330 (1100)	360 (1200)	m/min	SFM	
P5	KCP05/KTP10											240	800
	KCP10											215	720
	KCP25											195	650
	KCP30/KCP40											135	450
	KT315											250	800
	KCU10/KC5010											200	660

Ferritic, Martensitic, and PH Stainless Steels (340–450 HB) (36–48 HRC)

material group	grade	speed — m/min (SFM)									starting conditions		
		105 (350)	135 (450)	165 (550)	195 (650)	225 (750)	255 (850)	285 (950)	315 (1050)	345 (1150)	m/min	SFM	
P6	KCP05/KTP10											200	660
	KCP10											180	600
	KCP25											150	500
	KCP30/KCP40											105	350
	KT315											200	660
	KCU10/KC5010											150	500

Step 1 • Select the insert geometry



Negative Wiper Inserts



-MW
Medium Wiper



-FW
Finishing Wiper

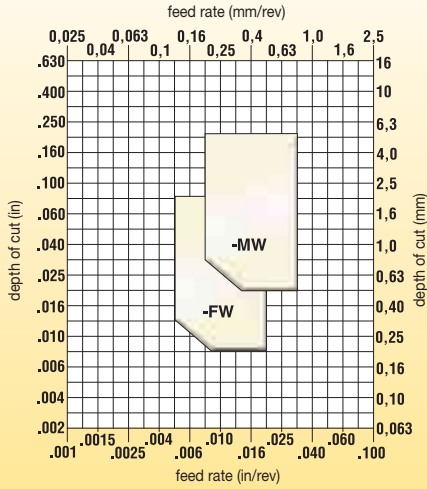

Positive Wiper Inserts



-MW
Medium Wiper



-FW
Finishing Wiper

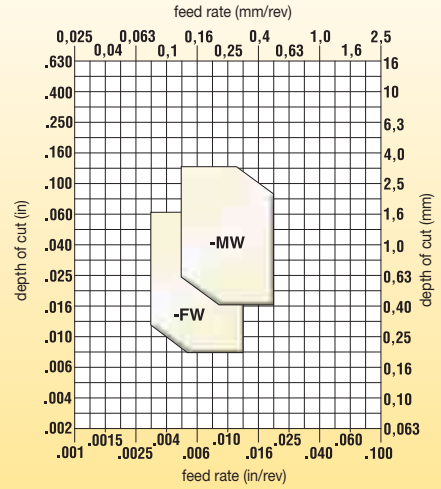

Step 2 • Select the grade

cutting condition	Negative Insert Geometry		Positive Insert Geometry	
	-FW	-MW	-FW	-MW
heavily interrupted cut	—	—	—	—
lightly interrupted cut	KCM15	KCM25	KCM15	KCM15
varying depth of cut, casting, or forging skin	KCM15/KCU10/KC5010	KCM15	KCU10/KC5010	KCU10/KC5010
smooth cut, pre-turned surface	KCM15/KT315	KCM15	KT315	KT315

Step 1 • Select the insert geometry



Negative Inserts



-RP **-P**
Roughing

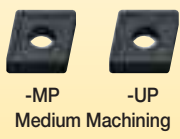

-MP **-UP**
Medium Machining



-FP **-FF**
Finishing

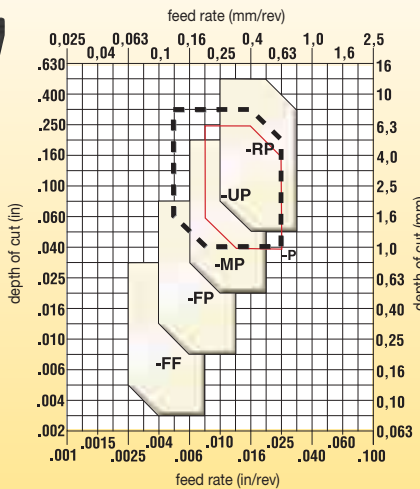

Positive Inserts



-MP
Medium Machining



-LF **..GT-LF**
Finishing



-11 **-UF**
Fine Finishing

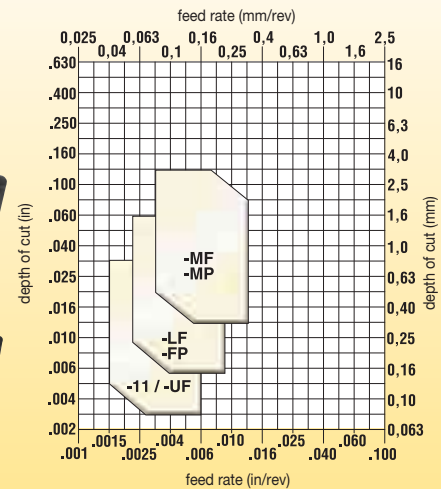

Step 2 • Select the grade

cutting condition	Negative Insert Geometry			
	-FF	-FP	-MP/-UP	-P/-RP
heavily interrupted cut	KCU10/KC5010	KCM15	KCM35	KCM35
lightly interrupted cut	KCU10/KC5010	KCM15	KCM25	KCM25
varying depth of cut, casting, or forging skin	KT315	KCM15/KC5010	KCM15	KCM15/KCM25
smooth cut, pre-turned surface	KT315	KCM15/KT315	KCM15/KU10	KCU10

(continued)

■ Step 2 • Select the grade *(continued)*

cutting condition		Positive Insert Geometry				
		-11	-UF	-LF	-MP/-MF	-FP
heavily interrupted cut		—	KCU25/KC5025	KCM35	KCM25	KCU25/KCM25
lightly interrupted cut		—	KCU10/KC5010	KCM25	KCM25	KCM15
varying depth of cut, casting, or forging skin		KT315	—	KCM15/KCU10	KCM15	KCU10
smooth cut, pre-turned surface		KT315	—	KCM15/KT315	KCM15	KTP10

■ Step 3 • Select the cutting speed

Austenitic Stainless Steel speed — m/min (SFM) ▶ starting conditions ◀

material group	grade	90 (300)	135 (450)	180 (600)	225 (800)	270 (900)	315 (1050)	360 (1200)	405 (1350)	450 (1500)	m/min	SFM
M1	KCM15										180	600
	KCM25										150	500
	KCM35										120	400
	KT315										230	750
	KCU10/KC5010										215	700
	KCU25/KC5025										180	550

Austenitic Stainless Steel speed — m/min (SFM) ▶ starting conditions ◀

material group	grade	90 (300)	135 (450)	180 (600)	225 (800)	270 (900)	315 (1050)	360 (1200)	405 (1350)	450 (1500)	m/min	SFM
M2	KCM15										165	550
	KCM25										140	450
	KCM35										105	350
	KT315										215	700
	KCU10/KC5010										200	650
	KCU25/KC5025										165	500

Austenitic Stainless Steel: Duplex (Ferritic and Austenitic Mixture) speed — m/min (SFM) ▶ starting conditions ◀

material group	grade	90 (300)	135 (450)	180 (600)	225 (800)	270 (900)	315 (1050)	360 (1200)	405 (1350)	450 (1500)	m/min	SFM
M3	KCM15										150	500
	KCM25										120	400
	KCM35										90	300
	KT315										200	650
	KCU10/KC5010										185	600
	KCU25/KC5025										150	450

Step 1 • Select the insert geometry



Negative Wiper Inserts



Medium Wiper



Finishing Wiper

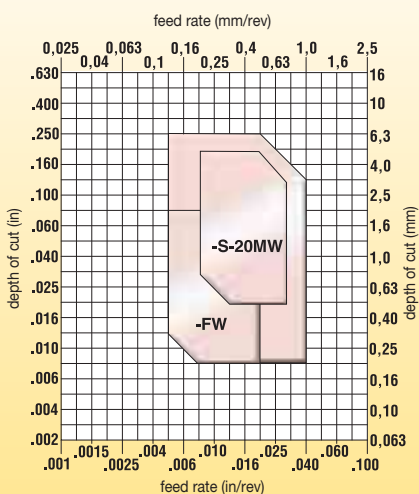

Positive Wiper Inserts



Medium Wiper



Finishing Wiper

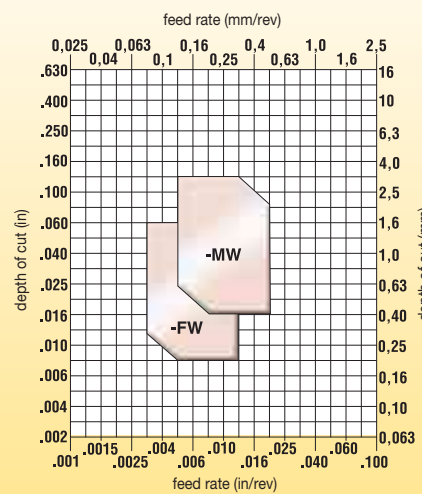

Step 2 • Select the grade

Grey Iron

cutting condition	Negative Insert Geometry			Positive Insert Geometry	
	-FW	-T-20FW	-S...MW...	-FW	-MW
heavily interrupted cut	⊖	—	KY3500	—	KCK20
lightly interrupted cut	⊕	KCK15	KY3500	KCK20	KCK20
varying depth of cut, casting, or forging skin	⊙	KCK05/KT315	KYK10	KCK20	KCK20
smooth cut, pre-turned surface	⊗	KCK05/KT315	KYK25	KCK20/KT315	KT315/KCK20

Ductile Iron

cutting condition	Negative Insert Geometry		Positive Insert Geometry	
	-FW	-T-20FW-	-FW	-MW
heavily interrupted cut	⊖	—	—	—
lightly interrupted cut	⊕	KCK15	KY3500	KCK20
varying depth of cut casting, or forging skin	⊙	KCK05/KT315	KYK10	KCK20
smooth cut, pre-turned surface	⊗	KCK05/KT315	KYK25	KCK20/KT315

■ Step 3 • Select the cutting speed

Grey Cast Iron

material group	grade	speed — m/min (SFM)									starting conditions		
		60 (200)	150 (500)	240 (800)	330 (1100)	420 (1400)	510 (1700)	600 (2000)	690 (2300)	780 (2600)	m/min	SFM	
K1	KCK05											450	1500
	KCK15											360	1200
	KCK20											300	1000
	KT315											275	900

Ductile, Compacted Graphite, and Malleable Cast Irons (<80 KSI tensile strength)

material group	grade	speed — m/min (SFM)									starting conditions		
		60 (200)	150 (500)	240 (800)	330 (1100)	420 (1400)	510 (1700)	600 (2000)	690 (2300)	780 (2600)	m/min	SFM	
K2	KCK05											360	1200
	KCK15											270	900
	KCK20											240	800
	KT315											275	900

Ductile, Compacted Graphite, and Malleable Cast Irons (>80 KSI tensile strength)

material group	grade	speed — m/min (SFM)									starting conditions		
		60 (200)	150 (500)	240 (800)	330 (1100)	420 (1400)	510 (1700)	600 (2000)	690 (2300)	780 (2600)	m/min	SFM	
K3	KCK05											240	800
	KCK15											215	725
	KCK20											210	700
	KT315											230	750

Step 1 • Select the insert geometry



Negative Inserts

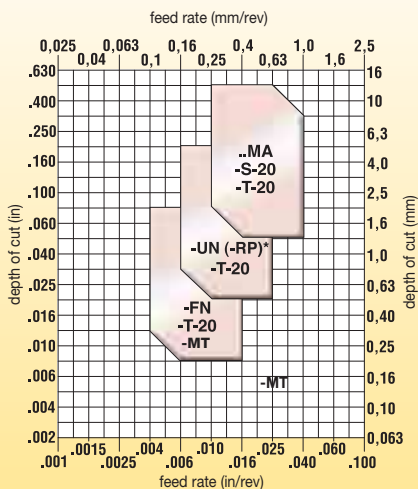

Positive Inserts

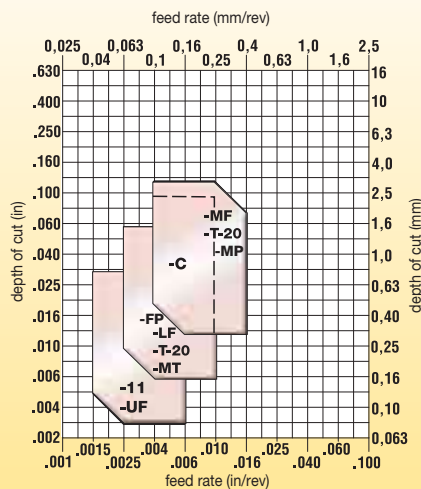

* Geometry can be used in medium machining operations to reduce tool pressure in high-strength metals.

Step 2 • Select the grade

Carbide Grades

Grey Iron

cutting condition	Negative Insert Geometry			Positive Insert Geometry				
	-FN	-UN(-RP)	-MA	-LF	-FP	-MF	-MP	-MW
heavily interrupted cut	⚙️ KCK15	KCK20	KCK20	KCK20	KCK20	KCK20	KCK20	KCK20
lightly interrupted cut	⚙️ KCK15	KCK20	KCK20	KCK20	KCK20	KCK20	KCK20	KCK20
varying depth of cut, casting, or forging skin	⊙ KCK05/KT315	KCK15	KCK15	KCK15	KCK20	KCK15	KCK20	KCK20
smooth cut, pre-turned surface	⊙ KCK05/KT315	KCK05	KCK05	KCK05	KCK20	KCK15	KCK20	KCK20

Ductile Iron

cutting condition	Negative Insert Geometry			Positive Insert Geometry					
	-FN	-UN(-RP)	-MA	-11/-UF	-LF	-MF	-FP	-MP	-MW
heavily interrupted cut	⚙️ KCK15	KCK20	KCK20	—	KCK20	KCK20	KCK20	KCK20	KCK20
lightly interrupted cut	⚙️ KCK15	KCK20	KCK20	—	KCK20	KCK20	KCK20	KCK20	KCK20
varying depth of cut, casting, or forging skin	⊙ KCK05/KT315	KCK15	KCK15	—	KCK15	KCK15	KCK20	KCK20	KCK20
smooth cut, pre-turned surface	⊙ KCK05/KT315	KCK05	KCK05	—	KCK15	KCK15	KCK20	KCK20	KCK20

(continued)

Step 2 • Select the grade *(continued)*
Ceramic and PCBN Grades
Grey Iron

cutting condition	Negative Insert Geometry					
		-T-20 Finishing	MT	-T-20 Medium	-T-20 Roughing	-S20
heavily interrupted cut	⚙️	KY3500	KCK20	KY3500	KY3500	KB1340
lightly interrupted cut	⚙️	KY3500	KB1345	KYK10	KY3500	KB1340
varying depth of cut, casting, or forging skin	⊖	KYK10	KB1345	KYK10	KYK10	KB1340
smooth cut, pre-turned surface	⊖	KYK25	KB1345	KYK25	KYK25	KB1340

cutting condition	Positive Insert Geometry				
		-T-20 Fine Finishing	-T-20 Medium	MT	C
heavily interrupted cut	⚙️	—	KY3500	KB1630/KB1345	KB1630/KB1345
lightly interrupted cut	⚙️	—	KY3500	KB1630/KB1345	KB1630/KB1345
varying depth of cut, casting, or forging skin	⊖	KY3500	—	—	—
smooth cut, pre-turned surface	⊖	KY3500	KY3500	KB1630/KB1345	KB1630/KB1345

Ductile Iron

cutting condition	Negative Insert Geometry			Positive Insert Geometry			
		-T-20 Finishing	-T-20 Medium	-T-20 Roughing	-T-20 Fine Finishing	-T-20 Finishing	-T-20 Medium
heavily interrupted cut	⚙️	—	KY3500	KY3500	—	KY3500	KY3500
lightly interrupted cut	⚙️	—	KYK25	KYK25	—	KYK25	KYK25
varying depth of cut, casting, or forging skin	⊖	KYK25	KYK25	KYK25	KYK25	KYK25	KYK25
smooth cut, pre-turned surface	⊖	KYK25	KYK25	KYK25	KYK25	KYK25	KYK25

Step 3 • Select the cutting speed *(Optimal speed depends on casting quality and disposition.)*
Grey Cast Iron

material group	grade	speed — m/min (SFM)										starting conditions			
		60 (200)	180 (600)	305 (1000)	430 (1400)	550 (1800)	675 (2200)	800 (2600)	920 (3000)	1040 (3400)	1160 (3800)	m/min	SFM		
K1	KT315													275	900
	KB1340/KB1345													760	2500
	KYK25													760	2500
	KY3500													760	2500
	KYK10													760	2500
	KCK05													450	1500
	KCK15													360	1200
	KCK20													300	1000

Ductile, Compacted Graphite, and Malleable Cast Irons (<600 MPa tensile strength)

material group	grade	speed — m/min (SFM)										starting conditions			
		90 (300)	135 (450)	180 (600)	225 (750)	275 (900)	320 (1050)	360 (1200)	410 (1350)	460 (1500)	500 (1650)	550 (1800)	600 (1950)	m/min	SFM
K2	KT315													275	900
	KCU10/KC5010													200	650
	KYK25													430	1400
	KY3500													365	1200
	KYK10													365	1200
	KCK05													360	1200
	KCK15													270	900
	KCK20													240	800

Ductile, Malleable, and Austempered Cast Irons (>600 MPa tensile strength)

material group	grade	speed — m/min (SFM)										starting conditions			
		90 (300)	135 (450)	180 (600)	225 (750)	275 (900)	320 (1050)	360 (1200)	410 (1350)	460 (1500)	500 (1650)	550 (1800)	600 (1950)	m/min	SFM
K3	KT315													230	750
	KCU10/KC5010													150	500
	KYK25													365	1200
	KCK05													240	800
	KCK15													215	725
	KCK20													210	700

Step 1 • Select the insert geometry



Negative Wiper Inserts

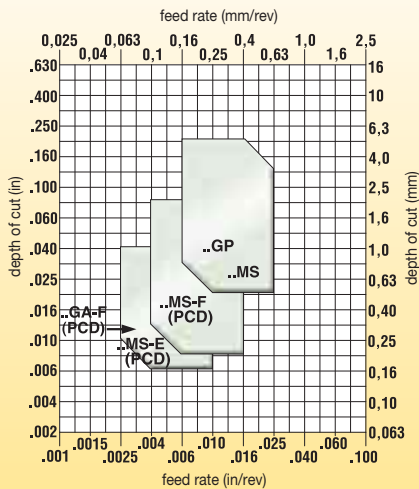
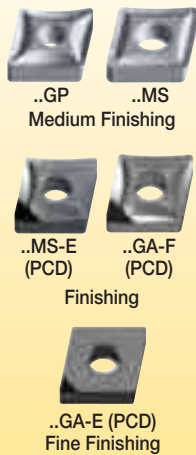

Positive Wiper Inserts

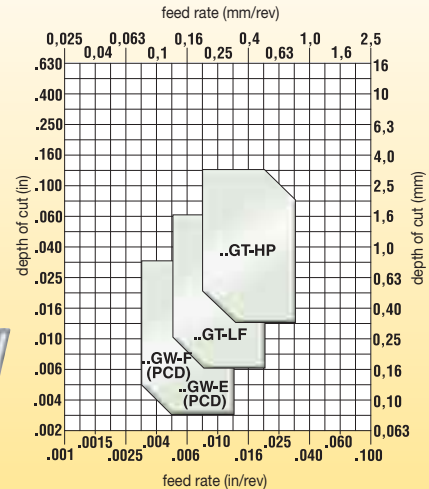

Step 2 • Select the grade

cutting condition	Negative Insert Geometry				Positive Insert Geometry				
	..GA-E (PCD)	..MS-E (PCD)	..GA-F (PCD)	..GP	..MS	..GW-E (PCD)	..GW-F (PCD)	..GT-LF	..GT-HP
heavily interrupted cut	—	—	KD1400	KC5410/K313	KC5410	—	KD1400	—	KC5410
lightly interrupted cut	KD1405	KD1405	KD1400	KC5410/K313	KC5410	KD1405	KD1400	KC5410	KC5410
varying depth of cut, casting, or forging skin	KD1405	KD1405	KD1425	KC5410/K313	KC5410	KD1405	KD1425	KC5410	KC5410
smooth cut, pre-turned surface	KD1405	KD1405	KD1425	KC5410/K313	KC5410	KD1405	KD1425	KC5410	KC5410

Step 3 • Select the cutting speed

Low-Silicon Aluminium Alloys

(hypo-eutectic <12,2% Si) and Magnesium Alloys

material group	grade	speed — m/min (SFM)										starting conditions		
		250 (800)	500 (1600)	750 (2400)	1000 (3200)	1250 (4000)	1500 (4800)	1750 (5600)	2000 (6400)	2250 (7200)	2500 (8000)	m/min	SFM	
N2	KC5410												550	1800
	KD1400												765	2500

High-Silicon Aluminium Alloys

(hyper-eutectic >12,2% Si) and Magnesium Alloys

material group	grade	speed — m/min (SFM)				starting conditions	
		250 (800)	500 (1600)	750 (2400)	1000 (3200)	m/min	SFM
N3	KD1405					580	2000
	KD1425					520	1700

■ Additional Cutting Speed Recommendations for Miscellaneous Workpiece Materials

Copper-, Brass-, Zinc-Based on a Machinability Index Range of 70–100

speed — m/min (SFM)

starting conditions ◊

material group	grade	250 (800)	500 (1600)	750 (2400)	1000 (3200)	m/min	SFM
N4	KD1400/ KD1405	◊				520	1700
	KD1425	◊				500	1600
	KC5410	◊				275	900
	K313	◊				260	850

Nylon, Plastics, Rubbers, Phenolics, Resins, Fibreglass, and Glass

speed — m/min (SFM)

starting conditions ◊

material group	grade	250 (800)	500 (1600)	750 (2400)	1000 (3200)	m/min	SFM
N5	KD1400/ KD1405	◊				400	1300
	KD1425	◊	◊			365	1200
	KC5410	◊				170	550

Carbon and Graphite Composites:

Brush Alloys, Kevlar, and Graphite (280–400 HB) (30–43 HRC)

speed — m/min (SFM)

starting conditions ◊

material group	grade	250 (800)	500 (1600)	750 (2400)	1000 (3200)	m/min	SFM
N6	KD1400/ KD1405	◊				760	2500
	KC5410	◊				200	650

MMCs (Aluminium-Based Metal Matrix Composites)

speed — m/min (SFM)

starting conditions ◊

material group	grade	250 (800)	500 (1600)	750 (2400)	1000 (3200)	m/min	SFM
N7	KD1405	◊				460	1500
	KD1400	◊				365	1200

Tin Alloys, Cast: ASTM 823, Alloys 1, 2, 3, 11

speed — m/min (SFM)

starting conditions ◊

material group	grade	250 (800)	500 (1600)	750 (2400)	1000 (3200)	m/min	SFM
N	KC5410	◊				215	700
	K313	◊				180	600

Step 1 • Select the insert geometry



Negative Inserts

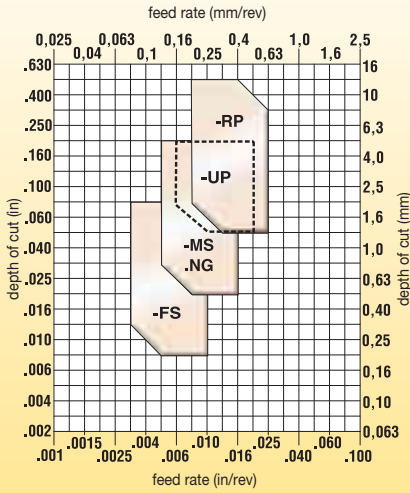

Positive Inserts

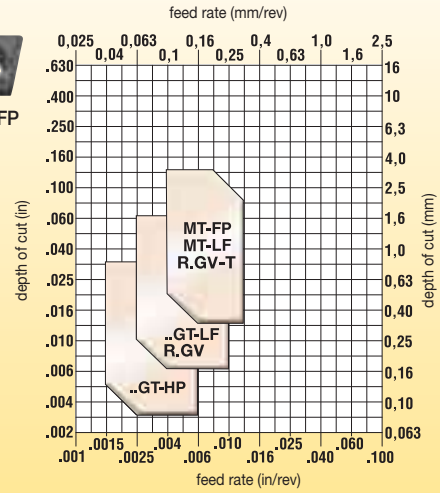
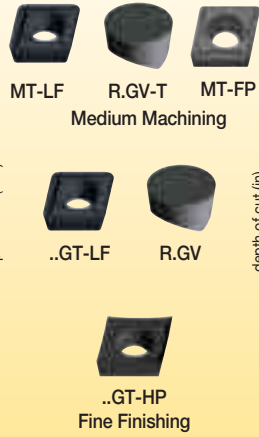

Step 2 • Select the grade

Negative Insert Geometry

cutting condition	-FS	.NG	-MS	-UP	-RP
heavily interrupted cut	⚙️ KCU25/KC5525	—	KCU25/KC5525	KCM35	KCM25/KCM35
lightly interrupted cut	⊙ KCU10/KC5510	KYS30/KY1540	KCU25/KC5525	KCM25	KCM15KC5525
varying depth of cut, casting, or forging skin	⊙ KCU10/KC5510	KYS30/KY1540/ KYS25/KY4300	KCU10/KC5510	KCM15	KCU25/KC5525
smooth cut, pre-turned surface	⊙ KCU10/KC5510/ K313	KYS25/KY4300	KCU10/KC5510 K313	KCU10/KC5510	KCU10/KC5510

Positive Insert Geometry

cutting condition	-FP	..GT-HP	MT-LF	R.GV-T	..GT-LF	R.GV
heavily interrupted cut	⚙️ KCU25	—	KCU25/KC5025	—	KCU25/KC5025	—
lightly interrupted cut	⊙ KCU25	KCU25/KC5025	KCU25/KC5025	KYS30/KY1540	KCU25/KC5025	KYS30/KY1540
varying depth of cut, casting, or forging skin	⊙ KCU10/KU10	KCU10/KC5510	KCU10/KC5510	KYS30/KY1540/ KYS25/KY4300	KCU10/KC5510	KYS30/KY1540/ KYS25/KY4300
smooth cut, pre-turned surface	⊙ KCU10/KU10	KCU10/KC5510 K313	KCU10/KC5510 K313	KYS25/KY4300	KCU10/KC5510 K313	KYS25/KY4300

■ Step 3 • Select the cutting speed

Iron-Based, Heat-Resistant Alloys (135–320 HB) (≤34 HRC)

speed — m/min (SFM)

starting conditions ◀

material group	grade	15 (50)	45 (150)	75 (250)	105 (350)	140 (450)	170 (550)	200 (650)	230 (750)	260 (850)	290 (950)	310 (1050)	350 (1150)	380 (1250)	m/min	SFM
S1	K313/KU10	◀													30	100
	KCU10/KC5510/KC5010		◀												55	180
	KCU25/KC5525/KC5025	◀													40	125
	KYS25/KY4300						◀								200	650
	KYS30/KY1540						◀								170	550
	KCM15		◀												55	180
	KCM25/KCM35	◀													40	125

Cobalt-Based, Heat-Resistant Alloys (150–425 HB) (≤45 HRC)

speed — m/min (SFM)

starting conditions ◀

material group	grade	15 (50)	45 (150)	75 (250)	105 (350)	140 (450)	170 (550)	200 (650)	230 (750)	260 (850)	290 (950)	310 (1050)	350 (1150)	380 (1250)	m/min	SFM
S2	K313/KU10	◀													35	110
	KC5510/KC5010		◀												60	195
	KC5525/KC5025	◀													30	100
	KYS25/KY4300						◀								220	720
	KYS30/KY1540						◀								185	600
	KCM15		◀												60	195
	KCM25/KCM35	◀													30	100

Nickel-Based, Heat-Resistant Alloys (140–475 HB) (≤48 HRC)

speed — m/min (SFM)

starting conditions ◀

material group	grade	15 (50)	45 (150)	75 (250)	105 (350)	140 (450)	170 (550)	200 (650)	230 (750)	260 (850)	290 (950)	310 (1050)	350 (1150)	380 (1250)	m/min	SFM
S3	K313/KU10	◀													40	125
	KCU10/KC5510/KC5010		◀												70	225
	KCU25/KC5525/KC5025	◀													40	125
	KYS25/KY4300							◀							250	820
	KYS30/KY1540							◀							215	700
	KCM15		◀												70	225
	KCM25/KCM35	◀													40	125

Titanium and Titanium Alloys (110–450 HB) (≤48 HRC)

speed — m/min (SFM)

starting conditions ◀

material group	grade	15 (50)	45 (150)	75 (250)	105 (350)	140 (450)	170 (550)	200 (650)	230 (750)	260 (850)	290 (950)	310 (1050)	350 (1150)	380 (1250)	m/min	SFM
S4	K313/KU10		◀												45	150
	KC5510/KC5010/KC9225		◀												70	225
	KC5525/KC50225/KC9240		◀												55	175
	KCM15			◀											70	225
	KCM25/KCM35		◀												55	175

Step 1 • Select the insert geometry

Negative Wiper Inserts

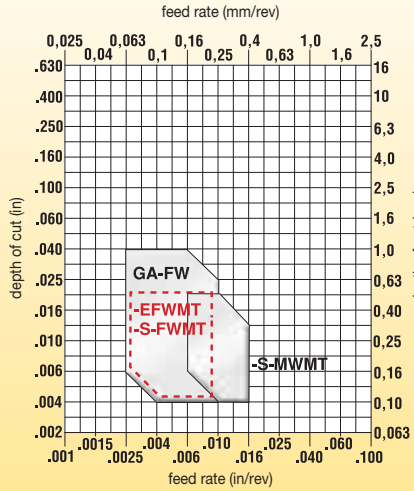

Positive Wiper Inserts

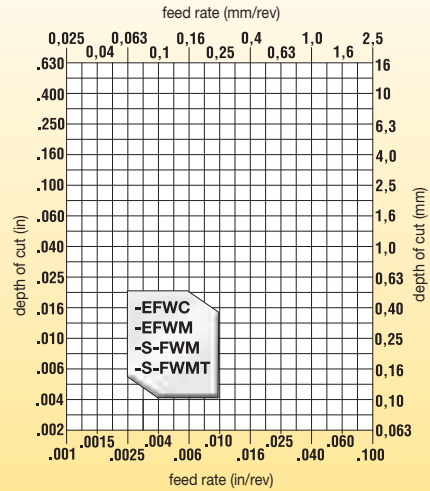

Step 2 • Select the grade

cutting condition	Symbol	Negative Insert Geometry			Positive Insert Geometry		
		GA-FW	-S..FWMT	-EFWMT	-S..FWMT	-S..FWM	-EFWC
heavily interrupted cut	⚙️	—	KB5630	KB1625	—	—	—
lightly interrupted cut	⚙️	—	KB1610/KB5610	KB5625	KB9610	KB1610	KB5610
varying depth of cut, casting, or forging skin	⚙️	KY4400	KB1610/KB5610	KB1610/KB5610	KB9610	KB1610	KB5610
smooth cut, pre-turned surface	⚙️	KY4400	KB9610	KB9610	KB9610	KB9610	KB9610

Step 1 • Select the insert geometry

Negative Inserts

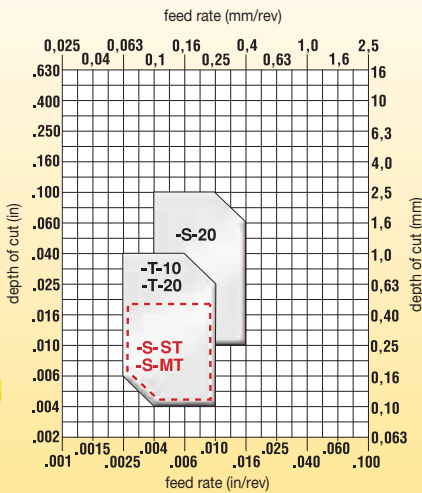
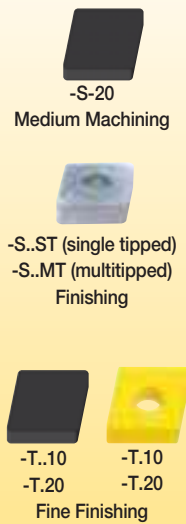

Positive Inserts

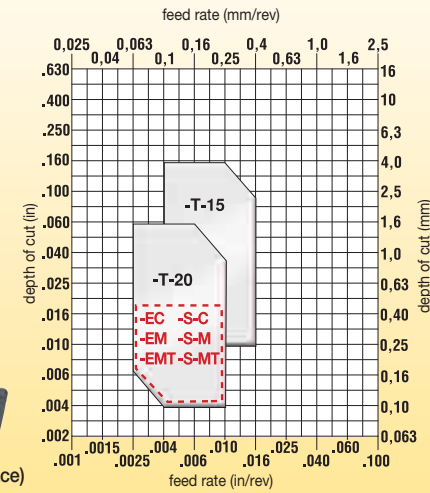
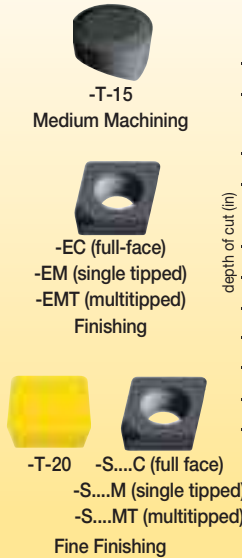

Step 2 • Select the grade

cutting condition	Symbol	Negative Insert Geometry				Positive Insert Geometry		
		-T-10	-S..ST	-S-20	-S..C/-S..M	-EC/-EM	-T-15	
heavily interrupted cut	⚙️	—	KB1630/KB5630	KB1340	KB1630/KB5630	—	KB1630/KB5630	—
lightly interrupted cut	⚙️	—	KB1625/KB5625	KB1340	KB1625/KB5625	KY4400	KB1625/KB5625	KY1615
varying depth of cut, casting, or forging skin	⚙️	KY1615/KY4400	KB1625/KB5625	—	KB1625/KB5625	KY4400	KB1625/KB5625	KY1615
smooth cut, pre-turned surface	⚙️	KY1615/KY4400	KB1610/KB5610	—	KB1610/KB5610	KY4400	KB1610/KB5610	KY1615

■ Step 3 • Select the cutting speed

material group	grade	speed — m/min (SFM)									starting conditions		
		15 (50)	45 (150)	75 (250)	110 (350)	140 (450)	170 (550)	200 (650)	230 (750)	260 (850)	m/min	SFM	
H1	KY4400											135	450
	KY1615											100	325
	KB1610											140	460
	KB1625											110	360
	KB1630											90	295
	KB5610											150	490
	KB5625											120	400
	KB5630											105	345

Inserts

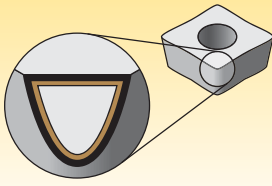

Coatings provide high-speed capability and are engineered for finishing to heavy roughing.

P	Steel
M	Stainless Steel
K	Cast Iron
N	Non-Ferrous Materials
S	High-Temp Alloys
H	Hardened Materials

wear resistance ← → toughness



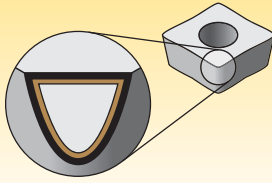

Coating	Grade Description	Wear Resistance / Toughness											
		05	10	15	20	25	30	35	40	45			
Uncoated Carbide Grades	KU10 C3 Composition: A hard, low binder content, WC/Co fine-grain grade. Application: The KU10 grade has excellent abrasion resistance for machining cast irons, austenitic stainless steels, non-ferrous metals, non-metals, and most high-temperature alloys. Use as a general-purpose grade for non-ferrous materials. beyond	M											
		K											
		N											
		S											
Uncoated Carbide Grades	K313 C3-C4 Composition: A hard, low binder content, unalloyed WC/Co fine-grain grade. Application: Exceptional edge wear resistance combined with very high strength for machining titanium, cast irons, austenitic stainless steels, non-ferrous metals, non-metals, and most high-temp alloys. Superior thermal deformation and depth-of-cut notch resistance. The grain structure is well controlled for minimal pits and flaws, which contributes to long, reliable service.	M											
		K											
		N											
		S											
Uncoated Carbide Grades	K68 C3 Composition: A hard, low binder content, alloyed grade WC/Co fine-grain grade. Application: The K68 grade has excellent abrasion resistance for machining cast irons, austenitic stainless steels, non-ferrous metals, non-metals, and as an alternative to the K313 grade on most high-temperature alloys. Use as a general-purpose grade for non-ferrous materials.	M											
		K											
		N											
		S											
PVD-Coated Carbide Grades	KCU10 C3-C4 Composition: An advanced multilayer PVD coating over a very deformation-resistant unalloyed carbide substrate. The new and improved coating improves edge stability with wide range speed and feed capabilities. Application: The KCU10 grade is ideal for finishing to general machining of most workpiece materials at a wide range of speed and feed capabilities. Excellent for machining most steels, stainless steels, cast irons, non-ferrous materials, and super alloys with improved edge toughness and higher cutting speed/feed capability. beyond	P											
		M											
		K											
		N											
		S											
		H											
	PVD-Coated Carbide Grades	KCU25 C2, C6 Composition: An advanced PVD grade with hard AlTiN coating and fine-grain unalloyed substrate. The new and improved coating improves edge stability with wide range speed and feed capabilities. Application: The KCU25 grade is ideal for general machining of most steels, stainless steels, high-temp alloys, titanium, irons, and non-ferrous materials in a wide range of speeds and feeds with improved edge toughness for interrupted cut and high feed rates. beyond	P										
			M										
			K										
			N										
			S										
PVD-Coated Carbide Grades	KC5010 C3-C4 Composition: An advanced PVD AlTiN coating over a very deformation-resistant unalloyed carbide substrate. The new and improved coating enables speeds to be increased by 50–100%. Application: The KC5010 grade is ideal for finishing to general machining of most workpiece materials at higher speeds. Excellent for machining most steels, stainless steels, cast irons, non-ferrous materials, and super alloys under stable conditions. It also performs well machining hardened and short chipping materials.	P											
		M											
		K											
		N											
		S											
		H											

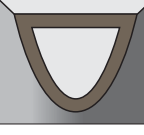

Coatings provide high-speed capability and are engineered for finishing to heavy roughing.

P	Steel
M	Stainless Steel
K	Cast Iron
N	Non-Ferrous Materials
S	High-Temp Alloys
H	Hardened Materials

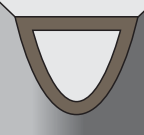
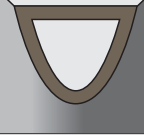
wear resistance ← → toughness

Coating	Grade Description	Performance Metrics										
		05	10	15	20	25	30	35	40	45		
PVD-Coated Carbide Grades KC5025 C2, C6 	Composition: An advanced PVD-AITiN-coated grade with a tough, ultra-fine-grain unalloyed substrate. Application: For general-purpose machining of most steels, stainless steels, high-temp alloys, titanium, irons, and non-ferrous materials. Speeds may vary from low to medium and will handle interruptions and high feed rates.	P										
		M										
		K										
		N										
		S										
KC5410 C3-C4 	Composition: A PVD TiB ₂ coating over a very deformation-resistant unalloyed substrate. Application: Designed for roughing, semi-finishing, and finishing of free machining (hypoeutectic <12.2% Si) aluminium, aluminium alloys, and magnesium alloys. The TiB ₂ coating is harder than TiN and TiAlN coatings and has an extremely smooth surface, resulting in reduced surface friction, speedy chip flow, and outstanding wear resistance. Built-up edge is prevented because this coating has a very low affinity for aluminium. The substrate is unalloyed and fine grained and offers sharp edges, smooth surfaces, and excellent thermal deformation resistance and edge integrity. Inserts with a ground periphery are polished before coating and have a sharp edge. Moulded inserts have a light hone.											
		N										
KC5510 C3-C4 	Composition: An advanced PVD AITiN-coated fine-grain tungsten carbide grade. Application: The KC5510 grade is specifically engineered for the productive machining of high-temp alloys. The fine-grain tungsten carbide 6% cobalt substrate has excellent toughness and deformation resistance while the advanced PVD coating enables metalcutting speeds double those of conventional PVD-coated cutting tools.	P										
		M										
		K										
		N										
		S										
KC5525 C2-C6 	Composition: Advanced PVD AITiN-coated fine-grain high-cobalt carbide grade. Application: The KC5525 grade utilises the same advanced PVD coating as the KC5510 grade in conjunction with a fine-grained tungsten carbide 10% cobalt substrate. The higher cobalt enables added security in interrupted cuts while the fine-grained WC maintains hardness-resisting deformation at higher speeds. Designed for medium to heavy interruptions in high-temp alloys.	P										
		M										
		K										
		N										
		S										
CVD-Coated Carbide Grades KCP05 C3-C4 	Composition: An innovative, highly deformation-resistant, cobalt-enriched substrate with a specially designed, adherent MTCVD-TiCN-Al ₂ O ₃ coating. Application: For finishing to semi-finishing of most steels, ferritic, martensitic, and PH stainless steels and cast irons. Provides excellent combination of deformation resistance and insert edge strength. The new coating combined with a state-of-the-art post-coat treatment provides high-productivity with long predictable tool life and superior workpiece surface finish.	P										
		K										
KCP10 C3, C7 	Composition: A specially engineered cobalt-enriched carbide grade with thick MTCVD-TiCN-Al ₂ O ₃ coating for maximum wear resistance. Application: An excellent finishing to medium machining grade for a variety of workpiece materials, including most steels, ferritic, martensitic, and PH stainless steels, and cast irons. The cobalt-enriched substrate offers a balanced combination of deformation resistance and edge toughness, while the thick coating layers offer outstanding abrasion resistance and crater wear resistance for high-speed machining. Smooth coating provides resistance to edge build-up and microchipping and produces excellent surface finishes.	P										
		K										



Inserts

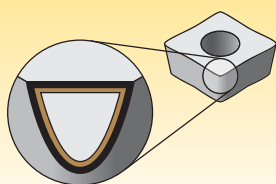

Coatings provide high-speed capability and are engineered for finishing to heavy roughing.

P	Steel
M	Stainless Steel
K	Cast Iron
N	Non-Ferrous Materials
S	High-Temp Alloys
H	Hardened Materials

wear resistance ← → toughness

Coating	Grade Description	Wear Resistance / Toughness										
		05	10	15	20	25	30	35	40	45		
KCP25 C2-C3, C6-C7	<p>Composition: A tough cobalt-enriched carbide grade with a newly designed multilayer MTCVD-TiCN-Al₂O₃ coating with superior interlayer adhesion.</p> <p>Application: Best general-purpose turning grade for most steels and ferritic and martensitic stainless steels. The substrate design ensures adequate deformation resistance with excellent insert edge strength. Coating layers offer good wear resistance over a wide range of machining conditions and the post-coat treatment minimises microchipping and improves coating adhesion to substrate leading to long tool life and improved workpiece finishes.</p>	P										
		K										
beyond												
KCP30 C5-C6	<p>Composition: A newly engineered, tough cobalt-enriched carbide grade with an advanced multilayer TiN-MT-TiCN-Al₂O₃ coating.</p> <p>Application: For medium to rough machining of all carbon, alloy, and stainless steels. The substrate design provides superior insert strength that is required for this application, and the multilayer coating adds wear resistance to the insert resulting in long tool life.</p>	P										
		K										
beyond												
KCP40 C5-C6	<p>Composition: A tough carbide grade with a moderately thick TiN-MT-TiCN-Al₂O₃ coating.</p> <p>Application: For heavy roughing of carbon, alloy, and stainless steels. The substrate-coating combination provides unbelievable toughness and operational security allowing high metal removal rates even in most demanding interrupted cuts.</p>	P										
		M										
beyond												
KCK05 C3-C4	<p>Composition: A multilayered coating with moderately thick MTCVD TiCN-Al₂O₃ layers over a highly deformation-resistant carbide substrate.</p> <p>Application: Designed for high-speed machining of grey and ductile irons. The substrate and coating architecture together with CW5 post-coat treatment ensure a tremendous tool life advantage, especially when cutting higher tensile strength ductile and grey irons where workpiece size consistency and reliability of tool life are critical. Excellent both in straight and varied depths of cut.</p>	P										
		K										
beyond												
KCK15 C3-C4	<p>Composition: A multilayered coating with thick MTCVD TiCN-Al₂O₃ layers applied over a carbide substrate specifically engineered for cast irons.</p> <p>Application: Delivers consistent performance in high-speed machining of grey and ductile irons. The substrate design permits the insert to stay in the cut for a long time at high speeds with minimum deformation. The thick CVD coating and post-coat treatment provide superior wear resistance ensuring long and consistent tool life. Can be applied both in straight and lightly interrupted cuts.</p>	P										
		K										
beyond												
KCK20 C2-C3	<p>Composition: A specially toughened MTCVD-TiCN-Al₂O₃ coating over a wear-resistant substrate.</p> <p>Application: The KCK20 grade is specifically engineered to maximise coating adhesion and edge strength making this grade ideal in wet interrupted cutting of grey and ductile irons. It can be used in a wide range of applications from finishing to roughing to maximise productivity wherever strength and reliability are needed.</p>	P										
		K										
beyond												

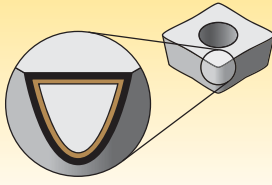

Coatings provide high-speed capability and are engineered for finishing to heavy roughing.

P	Steel
M	Stainless Steel
K	Cast Iron
N	Non-Ferrous Materials
S	High-Temp Alloys
H	Hardened Materials

wear resistance ← → toughness

CVD-Coated Carbide Grades

Coating	Grade Description	Material Group																					
		05	10	15	20	25	30	35	40	45													
KCM15 C2-C3	<p>Composition: A multilayer MTCVD-TiCN-Al₂O₃ coated carbide grade.</p> <p>Application: An excellent finishing to medium machining grade for austenitic stainless steels at higher speeds and covers a broad range of steel applications in the P20-25 range. KCM15 grade in combination with unique geometries have been designed to resist depth-of-cut notching and minimise burr formation. The post-coat treatment reduces coating stresses, improves coating adhesion, minimises microchipping and edge build-up, and improves workpiece finish.</p>	P																					
		M																					
KCM25 C1-C2	<p>Composition: A multilayer CVD coating comprised of TiN-MT-TiCN-Al₂O₃ layers over a tough, cobalt-enriched carbide substrate.</p> <p>Application: This CVD-coated grade is designed for general-purpose machining of austenitic stainless steels at moderate speeds and feeds. KCM25 inserts offer an extraordinary combination of toughness, built-up edge resistance, and wear resistance in stainless steel applications.</p>	P																					
		M																					
KCM35 C1-C2	<p>Composition: A multilayer TiN-MT-TiCN-Al₂O₃ CVD coating over a super-tough substrate.</p> <p>Application: The KCM35 grade is engineered to take on the most brutal cast stainless steel machining applications. The substrate withstands heavy interruptions, while the coating provides the wear resistance needed for long tool life. The polished surface resists edge build-up, even at slow cutting speeds. KCM35 grade is available in insert sizes and geometries appropriate for heavy feeds and large depths of cut.</p>	P																					
		M																					
KT315 C3, C7	<p>Composition: A multilayer PVD-TiN/TiCN/TiN-coated cermet turning grade.</p> <p>Application: Ideal for high-speed finishing to medium machining of most carbon and alloy steels and stainless steels. Performs very well in cast and ductile iron applications, too. Provides long and consistent tool life and will produce excellent workpiece finishes.</p>	P																					
		M																					
KTP10 C3, C7	<p>Composition: A multilayer, PVD-TiN/TiCN/TiN-coated cermet turning grade.</p> <p>Application: Ideal for high-speed finishing to medium machining of most carbon and alloy steels and stainless steels. Performs very well in cast and ductile iron applications, too. Provides long and consistent tool life and will produce excellent workpiece finishes.</p>	P																					
		M																					

Inserts

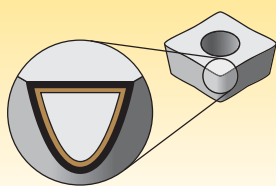

Coatings provide high-speed capability and are engineered for finishing to heavy roughing.

P	Steel
M	Stainless Steel
K	Cast Iron
N	Non-Ferrous Materials
S	High-Temp Alloys
H	Hardened Materials

wear resistance ← → toughness

Ceramic Grades

Coating	Grade Description	05	10	15	20	25	30	35	40	45
KYS25 C4	<p>Composition: SiAlON ceramic with a multi-layered alumina-TiCN CVD coating. Application: Compliments the KYS30 grade when machining high-temp and nickel-based alloys and cast materials with high Brinell hardness. This advanced CVD coating provides excellent chemical and depth-of-cut notch resistance compared to whisker ceramics.</p> <p>beyond</p>									
		S								
H										
KYS30 C4	<p>Composition: Latest and most advanced sialon material developed. Application: Combines excellent wear properties, fracture toughness, and thermal shock resistance for general-purpose to finish machining of high-temp alloys. Provides superior depth-of-cut notch resistance compared to whisker ceramics.</p> <p>beyond</p>									
		S								
KYK10 —	<p>Composition: An advanced sialon ceramic grade. Application: Provides maximum wear resistance. Use for high-speed continuous turning of grey cast iron, including through scale.</p> <p>beyond</p>									
		K								
KYK25 C3	<p>Composition: Pure silicon nitride ceramic with an alumina CVD coating. Application: Excellent combination of toughness and edge wear resistance. Used for general-purpose machining of grey, ductile, or nodular cast irons.</p> <p>beyond</p>									
		K								

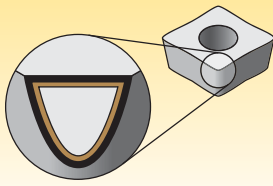

Coatings provide high-speed capability and are engineered for finishing to heavy roughing.

P	Steel
M	Stainless Steel
K	Cast Iron
N	Non-Ferrous Materials
S	High-Temp Alloys
H	Hardened Materials

Inserts

wear resistance ← → toughness

Coating	Grade Description	Wear Resistance / Toughness										
		05	10	15	20	25	30	35	40	45		
Ceramic Grades	 KY4300 C4 Composition: Whisker ceramic with a matrix of Al ₂ O ₃ + SiC. Application: The SiC whiskers embedded in the micro structure give this ceramic excellent toughness for cutting high-temp alloys and cast materials with high Brinell hardness.	M										
	 KY3500 C2 Composition: Pure silicon nitride grade. Application: Maximum toughness. Used at high feed rates for rough machining of grey cast iron, including machining through interruptions.	K										
	 KY4400 C4, C8 Composition: A PVD TiN coating over an aluminium oxide and titanium carbonitride composite ceramic (Al ₂ O ₃ /TiCN). Application: Used for finish turning of hardened steels and irons (greater than 45 HRC). Where possible, use under dry conditions in smooth or varied depths of cut. Can also be applied in finish turning of nickel alloys, cobalt alloys, and powder metals.	H										
PCBN – Polycrystalline Cubic Born Nitride Grades	 KB1340 — Composition: A high CBN content, solid PCBN insert having multiple cutting edges. Application: Applied in roughing to finishing of fully pearlitic grey cast iron, chilled irons, high-chrome alloyed steels, sintered powdered metals, and heavy cuts in hardened steels (>45 HRC). Also use for finishing chilled cast iron and fully pearlitic cast iron. The solid PCBN insert offers better security and shock resistance compared to tipped PCBN inserts, while also enabling deeper depth-of-cut capabilities.	K										
	 KB1345 — Composition: A high CBN content, PCBN tip brazed onto a carbide insert. Application: Applied in roughing to finishing of fully pearlitic grey cast iron, chilled irons, high-chrome alloyed steels, sintered powdered metals, and heavy cuts in hardened steels (>45 HRC). Also use for finishing chilled cast iron and fully pearlitic cast iron. The tipped PCBN insert is available in a wide range of insert styles including positive rake geometries that are ideally suited for boring applications.	K										
	 KB1610 — Composition: A low CBN content, PCBN tip brazed onto a carbide insert. Application: Designed for precision finishing in smooth cuts on hardened steels (>45 HRC) where optimal surface finish is needed. Use on bearing steel, hot and cold work tool steels, high-speed steels, die steels, case hardened steels, carburised and nitrided irons, and some hard coatings. Do not apply on soft steel.	H										

Inserts

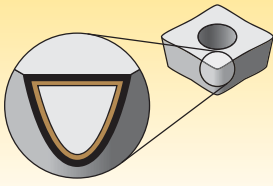





Coatings provide high-speed capability and are engineered for finishing to heavy roughing.

P	Steel
M	Stainless Steel
K	Cast Iron
N	Non-Ferrous Materials
S	High-Temp Alloys
H	Hardened Materials

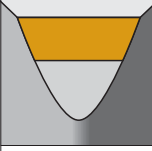
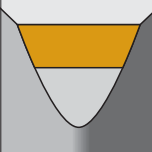
wear resistance ← → toughness

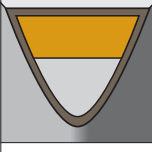
PCBN – Polycrystalline Cubic Born Nitride Grades

Coating	Grade Description	05	10	15	20	25	30	35	40	45
 KB1625 —	<p>Composition: A medium CBN content, PCBN tip brazed onto a carbide insert.</p> <p>Application: Designed for roughing to finishing of hardened steels (>45 HRC) where optimal surface finish is needed. It can be used in continuous to interrupted cutting of bearing steel, hot and cold work tool steels, high-speed steels, die steels, case-hardened steels, carburised and nitrided irons, and some hard coatings.</p>									
 KB1630 —	<p>Composition: A high CBN content, PCBN tip brazed onto a carbide insert.</p> <p>Application: Designed for roughing to finishing in interrupted cuts on hardened steels (>45 HRC). It can also be applied on grey cast iron, chilled irons, high-chrome alloyed steels, and sintered powdered metals. The tipped PCBN insert is available in a wide range of insert styles, including positive rake geometries, that are ideally suited for boring applications.</p>									
 KB5610 C4, C8	<p>Composition: A low content PCBN grade with a PVD TiAlN coating for added wear resistance.</p> <p>Application: Designed for the precision machining of hardened steels (>45 HRC). The PVD coating offers improved wear resistance and excellent surface finish capabilities. It can be very effectively applied on bearing steels, hot and cold work tool steels, high-speed steels, die steels, case-hardened steels, carburised and nitrided irons, and some hard coatings. Available in a multitip format with a tremendous breadth of edge preps, insert styles, and wiper geometries.</p>									
 KB5625 C4, C8	<p>Composition: A PVD TiAlN coating over a medium content, PCBN tip brazed onto a carbide insert.</p> <p>Application: Designed for roughing to finishing of hardened steels (>45 HRC). Use on bearing steel, hot and cold work tool steels, high-speed steels, die steels, case-hardened steels, carburised and nitrided irons, and some hard coatings.</p>									
 KB5630 C4, C8	<p>Composition: A high content PCBN grade with a PVD AlTiN coating for added wear resistance.</p> <p>Application: Designed for roughing to finishing in hardened steels (>45 HRC), abrasive workpiece materials such as sintered valve seat materials, powder metallurgy tool steels, and hard high-alloy cast irons. The PVD coating provides resistance to crater wear and increased resistance to chipping. The tipped PCBN insert is available in a wide range of insert styles, including positive rake geometries, that are ideally suited for boring applications.</p>									

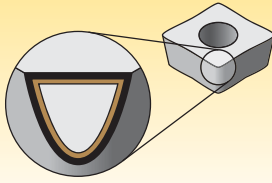

Coatings provide high-speed capability and are engineered for finishing to heavy roughing.

P	Steel
M	Stainless Steel
K	Cast Iron
N	Non-Ferrous Materials
S	High-Temp Alloys
H	Hardened Materials

wear resistance ← → toughness

PCD – Polycrystalline Diamond Grades

Coating	Grade Description	05	10	15	20	25	30	35	40	45
KD1400 —	Composition: An ultra-fine-grain, polycrystalline diamond (PCD) tip brazed onto a carbide substrate. Application: Designed for general-purpose turning of primarily non-ferrous materials. It can be applied over a wide range of continuous to interrupted cuts where superior surface finish is needed. Use on low to medium silicon-content aluminium alloys, non-metallics, copper, and brass- and zinc-based alloys. The ultra-fine-grain diamond particle size enables superior surface finishes while ensuring the best mechanical shock resistance of any PCD cutting tool.									
KD1405 —	Composition: A pure CVD-deposited diamond-sheet tool brazed directly to a carbide substrate. Application: KD1405 is Kennametal's most abrasion-resistant tool material for non-ferrous and non-metallic materials. Best applied when abrasion resistance is the desired benefit.									
KD1425 —	Composition: A multimodal PCD grade with a range of grain sizes brazed onto a carbide substrate. Application: Engineered for extreme abrasion resistance, combined with good edge strength for demanding applications. An ideal choice for high-silicon aluminium alloys, bi-metallic (AL/GC) materials, MMC, carbon-fibre reinforced plastics, and other abrasive non-metallic materials.									

■ Select the geometry — based on feed rate and depth of cut

P	Steel
M	Stainless Steel
K	Cast Iron
N	Non-Ferrous Materials
S	High-Temp Alloys
H	Hardened Materials

operation	insert style application	insert geometry	profile	feed rate — mm										
				0,04	0,063	0,01	0,16	0,25	0,4	0,63	1,0	1,6	2,5	5,0
				depth of cut — mm										
				0,1	0,16	0,25	0,4	0,63	1,0	1,6	2,5	4,0	6,3	10,0
medium machining	MG-MP													
				0,2–0,5							0,8–5,1			

Pictorial View of Insert

Depth-of-Cut Range —
for all inserts in the program, select smaller inserts for lighter cuts and larger inserts for heavy cuts

Feed Rate Range —
for best results, use the centre 60% of the range

Chipbreaker Geometry —
section is through nose radius of insert

Primary Workpiece Material Group

P	Steel
M	Stainless Steel
K	Cast Iron
N	Non-Ferrous Materials
S	High-Temp Alloys
H	Hardened Materials

Chip Control Geometry Designation —
example: MG-MP = CNMG-432MP

Machining Operation —
for what the insert geometry is designed

NOTE: For detailed grade and geometry recommendations, reference the Kennametal Beyond™ Selection System on pages B8–B23.



■ Select the geometry — based on feed rate and depth of cut

P	Steel
M	Stainless Steel
K	Cast Iron
N	Non-Ferrous Materials
S	High-Temp Alloys
H	Hardened Materials

operation	insert style application	insert geometry	profile	feed rate — mm										
				0,04	0,063	0,01	0,16	0,25	0,4	0,63	1,0	1,6	2,5	5,0
				0,1	0,16	0,25	0,4	0,63	1,0	1,6	2,5	4,0	6,3	10,0
				depth of cut — mm										
wiper finishing	MG-FW			0,2–2,0										
				0,3–2,0										
	MG-FW1			0,1–1,5										
				0,1–1,5										
wiper medium machining	MG-MW			0,3–0,6										
				0,8–5,1										
	MG-MW1			0,15–0,5										
				0,5–3										
wiper roughing	MM-RW			0,3–1,3										
				1,3–12,7										
fine finishing	MG-FF			0,1–0,3										
				0,1–2,0										
finishing sharp	GG-FS precision ground			0,07–0,25										
				0,20 - 2,0										
finishing	GG-LF precision ground			0,1 - 0,5										
				0,5–3,0										

■ Select the geometry — based on feed rate and depth of cut

P	Steel
M	Stainless Steel
K	Cast Iron
N	Non-Ferrous Materials
S	High-Temp Alloys
H	Hardened Materials

operation	insert style application	insert geometry	profile	feed rate — mm																		
				0,04	0,063	0,01	0,16	0,25	0,4	0,63	1,0	1,6	2,5	5,0								
				0,1	0,16	0,25	0,4	0,63	1,0	1,6	2,5	4,0	6,3	10,0								
				depth of cut — mm																		
finishing	MG-FP								0,1-0,3													
										0,3-2,5												
	MG-FH								0,05-0,25													
										0,25-1												
	MG-FN								0,1-0,3													
									0,3-2,5													
	MG-FX								0,07-0,22													
									0,2-1													
	MP-K								0,1-0,3													
										0,2-2,5												
medium machining	MG-MH								0,15-0,5													
										0,3-2												
	MG-MX								0,15-0,35													
										0,5-1,5												
medium sharp	MG-MS								0,12-0,35													
																					0,76-5,0	

Select the geometry —
based on feed rate and depth of cut

P	Steel
M	Stainless Steel
K	Cast Iron
N	Non-Ferrous Materials
S	High-Temp Alloys
H	Hardened Materials

operation	insert style application	insert geometry	profile	feed rate — mm																		
				0,04	0,063	0,01	0,16	0,25	0,4	0,63	1,0	1,6	2,5	5,0								
				depth of cut — mm																		
				0,1	0,16	0,25	0,4	0,63	1,0	1,6	2,5	4,0	6,3	10,0								
roughing	MG-RP									0,2-0,6			1,1-6,4									
	MG-RN						0,3-0,25						1,1-6,4									
heavy roughing	MG							0,3-0,8					1,1-5,7									
	MM-RM single sided									0,3-1,0			1,3-12,7									
	MM-RP									0,2-1,0			1,3-10,0									
	MM-RH single sided							0,4-1,3					1,3-12,7									
wiper finishing	MT-FW							0,1-0,3				0,2-1,5										
wiper, medium finishing	MT-MW							0,1-0,5					0,4-3,3									

■ Select the geometry — based on feed rate and depth of cut

P	Steel
M	Stainless Steel
K	Cast Iron
N	Non-Ferrous Materials
S	High-Temp Alloys
H	Hardened Materials

operation	insert style application	insert geometry	profile	feed rate — mm																			
				0,04	0,063	0,01	0,16	0,25	0,4	0,63	1,0	1,6	2,5	5,0									
				depth of cut — mm																			
fine finishing	_GM precision ground			0,1–0,2		0,2–1,0																	
						0,1–0,3		0,2–1,3															
						0,1–0,3		0,1–1,3															
finishing	GT-HP precision ground					0,2–0,4						0,6–2,3											
						0,2–0,4						0,8–2,3											
						0,063–0,25		0,16–1,6															
						0,2–0,4		0,8–2,3															
medium machining	MT-MP					0,01–0,4						0,4–2,3											
						0,2–0,4		1,1–2,3															
	MT-MF					0,2–0,4						1,1–2,3											



Carbide Inserts

Primary Application

Kennametal offers a complete portfolio of ISO-/ANSI-style inserts. Positive, negative, CVD, PVD, or uncoated, we have the insert to help increase productivity and achieve greater savings.

Plus, our carbide insert line contains Beyond™ technology. Beyond inserts offer you greater versatility, reliability, and up to 30% higher productivity.

Beyond™ CVD Grades

- Higher productivity and profitability — up to 300% higher.
- Lower cutting forces — Increase speeds and reduce cycle time.
- Extended tool life.
- Predictable tool life / Uniform wear.
- Resists chip flow damage.
- Consistent surface finish.
- Products can be applied across a wide range of applications.
- Use it in low speed to high speed applications.
- For finish to rough turning of steel, cast iron, stainless steel, and high temp alloy turning.

Beyond™ PVD Grades

KCU10™

- PVD-coated grade with superior wear resistance at elevated temperatures, allowing higher metal cutting speeds.
- For use in all materials, especially stainless steels and high-temp alloys.
- Improved depth-of-cut notch resistance.
- Increase speed by 20–30% or feed by 10–15%.
- Use in finishing to medium applications.

KCU25™

- PVD-coated grade with superior edge toughness and excellent wear resistance. Medium to roughing applications.
- Use in all materials.
- Increase speed, feed, and depth of cut by 10–20%.



Inserts

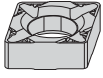

CNGG-FBB

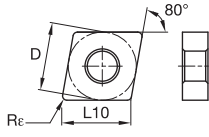

● first choice
○ alternate choice

beyond BLAST™

ISO catalogue number	D	L10	Re																									
	mm	mm	mm	KCP05	KCP10	KCP25	KCP30	KCP40	KCK05	KCK15	KCK20	KCM15	KCM25	KCM35	KU10	K313	K68	KCS10	KCU10	KCS010	KCS510	KCU25	KCS025	KCS525	KCS410	KT315	KTP10	
CNGG120404FBB	12,70	12,90	0,4																									
CNGG120408FBB	12,70	12,90	0,8													●				●								



CNGG-FS

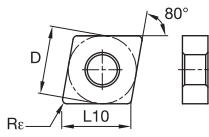

ISO catalogue number	D	L10	Re																									
	mm	mm	mm	KCP05	KCP10	KCP25	KCP30	KCP40	KCK05	KCK15	KCK20	KCM15	KCM25	KCM35	KU10	K313	K68	KCS10	KCU10	KCS010	KCS510	KCU25	KCS025	KCS525	KCS410	KT315	KTP10	
CNGG120401FS	12,70	12,90	0,1																	●		●						
CNGG120402FS	12,70	12,90	0,2																	●		●	●					
CNGG120404FS	12,70	12,90	0,4													●			●		●	●						
CNGG120408FS	12,70	12,90	0,8													●			●		●	●				●		
CNGG120412FS	12,70	12,90	1,2																●		●							



CNGG-LF

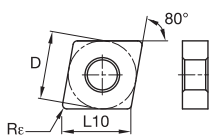

ISO catalogue number	D	L10	Re																									
	mm	mm	mm	KCP05	KCP10	KCP25	KCP30	KCP40	KCK05	KCK15	KCK20	KCM15	KCM25	KCM35	KU10	K313	K68	KCS10	KCU10	KCS010	KCS510	KCU25	KCS025	KCS525	KCS410	KT315	KTP10	
CNGG120401LF	12,70	12,90	0,1													●			●	●								
CNGG120402LF	12,70	12,90	0,2													●			●	●		●						
CNGG120404LF	12,70	12,90	0,4													●			●	●		●	●					
CNGG120408LF	12,70	12,90	0,8																●		●	●						
CNGG120412LF	12,70	12,90	1,2																●		●							
CNGG160608LF	15,88	16,12	0,8																●		●	●						
CNGG160612LF	15,88	16,12	1,2																●		●							



CNGP

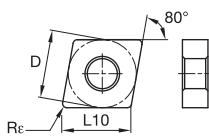

ISO catalogue number	D	L10	Re																									
	mm	mm	mm	KCP05	KCP10	KCP25	KCP30	KCP40	KCK05	KCK15	KCK20	KCM15	KCM25	KCM35	KU10	K313	K68	KCS10	KCU10	KCS010	KCS510	KCU25	KCS025	KCS525	KCS410	KT315	KTP10	
CNGP120401	12,70	12,90	0,1																	●	●							●
CNGP120402	12,70	12,90	0,2																	●	●		●					●
CNGP120404	12,70	12,90	0,4													●			●	●		●	●					●
CNGP120408	12,70	12,90	0,8													●			●	●		●	●					●
CNGP120412	12,70	12,90	1,2													●			●	●		●	●					●
CNGP120416	12,70	12,90	1,6													●			●	●		●	●					●

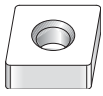

CNMA

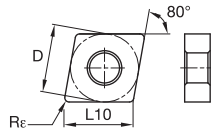

- first choice
- alternate choice

P	M	K	N	S	H																										
●	●	●	●																												
●	●																●	●				●	●								
																		●	●												



Inserts

ISO catalogue number	D	L10	Rø																										
	mm	mm	mm	KCP05	KCP10	KCP25	KCP30	KCP40	KCK05	KCK15	KCK20	KCM15	KCM25	KCM35	KU10	K313	K68	KCS10	KCU10	KC5010	KC5510	KCU25	KC5025	KC5525	KC5410	KT315	KTP10		
CNMA120404	12,70	12,90	0,4						●	●	●																		
CNMA120408	12,70	12,90	0,8						●	●	●					●	●												
CNMA120412	12,70	12,90	1,2						●	●	●					●													
CNMA120416	12,70	12,90	1,6						●	●	●																		
CNMA160608	15,88	16,12	0,8						●	●	●																		
CNMA160612	15,88	16,12	1,2						●	●	●																		
CNMA160616	15,88	16,12	1,6						●	●	●																		
CNMA190608	19,05	19,34	0,8						●	●	●																		
CNMA190612	19,05	19,34	1,2						●	●	●																		
CNMA190616	19,05	19,34	1,6						●	●	●																		



CNMG

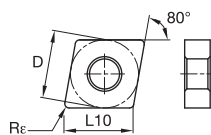

ISO catalogue number	D	L10	Rø																										
	mm	mm	mm	KCP05	KCP10	KCP25	KCP30	KCP40	KCK05	KCK15	KCK20	KCM15	KCM25	KCM35	KU10	K313	K68	KCS10	KCU10	KC5010	KC5510	KCU25	KC5025	KC5525	KC5410	KT315	KTP10		
CNMG120404B	12,70	12,90	0,4															●	●										
CNMG120408	12,70	12,90	0,8														●	●											
CNMG120412	12,70	12,90	1,2															●	●										
CNMG160612	15,88	16,12	1,2															●	●										
CNMG190608	19,05	19,34	0,8						●	●								●	●										
CNMG190612	19,05	19,34	1,2						●	●								●	●		●	●							
CNMG190616	19,05	19,34	1,6						●	●																			
CNMG250924	25,40	25,79	2,4						●	●																			



Inserts

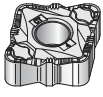

■ CNMG-CT

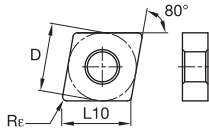

● first choice
○ alternate choice

ISO catalogue number	D mm	L10 mm	Re mm																								
				KCP05	KCP10	KCP25	KCP30	KCP40	KCK05	KCK15	KCK20	KCM15	KCM25	KCM35	KU10	K313	K68	KCS10	KCU10	KCS010	KCS510	KCU25	KCS025	KCS525	KCS410	KT315	KTP10
CNMG120408CT	12,70	12,90	0,8	●	●	●												●	●								
CNMG120412CT	12,70	12,90	1,2	●	●	●												●	●								
CNMG120416CT	12,70	12,90	1,6			●																					



■ CNMG-FF

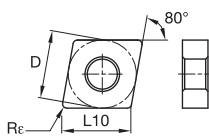

ISO catalogue number	D mm	L10 mm	Re mm																								
				KCP05	KCP10	KCP25	KCP30	KCP40	KCK05	KCK15	KCK20	KCM15	KCM25	KCM35	KU10	K313	K68	KCS10	KCU10	KCS010	KCS510	KCU25	KCS025	KCS525	KCS410	KT315	KTP10
CNMG090304FF	9,53	9,67	0,4		●														●	●							●
CNMG090308FF	9,53	9,67	0,8		●														●	●							
CNMG120404FF	12,70	12,90	0,4	●	●														●	●							●
CNMG120408FF	12,70	12,90	0,8	●	●														●	●							●

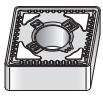

■ CNMG-FN

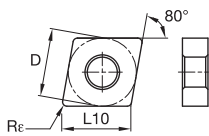

ISO catalogue number	D mm	L10 mm	Re mm																								
				KCP05	KCP10	KCP25	KCP30	KCP40	KCK05	KCK15	KCK20	KCM15	KCM25	KCM35	KU10	K313	K68	KCS10	KCU10	KCS010	KCS510	KCU25	KCS025	KCS525	KCS410	KT315	KTP10
CNMG090304FN	9,53	9,67	0,4		●																						●
CNMG090308FN	9,53	9,67	0,8		●																						●
CNMG120402FN	12,70	12,90	0,2																●	●							●
CNMG120404FN	12,70	12,90	0,4																								●
CNMG120408FN	12,70	12,90	0,8	●	●	●																					●
CNMG120412FN	12,70	12,90	1,2	●	●	●																					●
CNMG120416FN	12,70	12,90	1,6		●	●																					



■ CNMG-FP

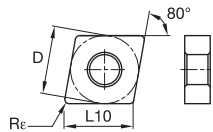

● first choice
○ alternate choice

ISO catalogue number	D mm	L10 mm	Re mm																	Material																								
																				P	M	K	N	S	H	KCP05	KCP10	KCP25	KCP30	KCP40	KCK05	KCK15	KCK20	KCM15	KCM25	KCM35	KU10	K313	K68	KCS10	KCU10	KC5010	KCU25	KC5025
CNMG120404FP	12,70	12,90	0,4																																					●				
CNMG120408FP	12,70	12,90	0,8																																							●		
CNMG120412FP	12,70	12,90	1,2																																									



■ CNMG-FW

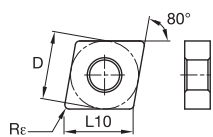

ISO catalogue number	D mm	L10 mm	Re mm																		Material																								
																					P	M	K	N	S	H	KCP05	KCP10	KCP25	KCP30	KCP40	KCK05	KCK15	KCK20	KCM15	KCM25	KCM35	KU10	K313	K68	KCS10	KCU10	KC5010	KCU25	KC5025
CNMG120404FW	12,70	12,90	0,4																																									●	
CNMG120408FW	12,70	12,90	0,8																																										
CNMG120412FW	12,70	12,90	1,2																																										

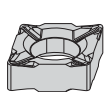

■ CNMG-MBB

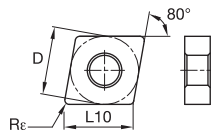

beyond BLAST™

ISO catalogue number	D mm	L10 mm	Re mm																		Material																								
																					P	M	K	N	S	H	KCP05	KCP10	KCP25	KCP30	KCP40	KCK05	KCK15	KCK20	KCM15	KCM25	KCM35	KU10	K313	K68	KCS10	KCU10	KC5010	KCU25	KC5025
CNMG120404MBB	12,70	12,90	0,4																																										
CNMG120408MBB	12,70	12,90	0,8																																										



Inserts

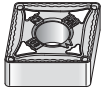

■ CNMG-MN

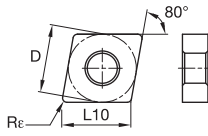

- first choice
- alternate choice

ISO catalogue number	D	L10	Re	Material Groups																								
	mm	mm	mm	KCP05	KCP10	KCP25	KCP30	KCP40	KCK05	KCK15	KCK20	KCM15	KCM25	KCM35	KU10	K313	K68	KCS10	KCU10	KC5010	KCU25	KC5025	KC5525	KC5410	KT315	KTP10		
CNMG090304MN	9,53	9,67	0,4	●	●	●	●	●																				
CNMG090308MN	9,53	9,67	0,8	●	●	●	●	●																				
CNMG090312MN	9,53	9,67	1,2	●	●	●	●	●																				
CNMG120404MN	12,70	12,90	0,4	●	●	●	●	●																				
CNMG120408MN	12,70	12,90	0,8	●	●	●	●	●																				
CNMG120412MN	12,70	12,90	1,2	●	●	●	●	●																				
CNMG120416MN	12,70	12,90	1,6	●	●	●	●	●																				
CNMG160608MN	15,88	16,12	0,8	●	●	●	●	●																				
CNMG160612MN	15,88	16,12	1,2	●	●	●	●	●																				
CNMG160616MN	15,88	16,12	1,6	●	●	●	●	●																				
CNMG190608MN	19,05	19,34	0,8	●	●	●	●	●																				
CNMG190612MN	19,05	19,34	1,2	●	●	●	●	●																				
CNMG190616MN	19,05	19,34	1,6	●	●	●	●	●																				

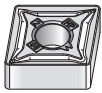

■ CNMG-MP

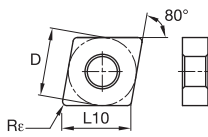

ISO catalogue number	D	L10	Re	Material Groups																									
	mm	mm	mm	KCP05	KCP10	KCP25	KCP30	KCP40	KCK05	KCK15	KCK20	KCM15	KCM25	KCM35	KU10	K313	K68	KCS10	KCU10	KC5010	KCU25	KC5025	KC5525	KC5410	KT315	KTP10			
CNMG090308MP	9,53	9,67	0,8									●	●						●	●									
CNMG120404MP	12,70	12,90	0,4									●	●	●					●	●									
CNMG120408MP	12,70	12,90	0,8	●	●							●	●	●					●	●			●	●					
CNMG120412MP	12,70	12,90	1,2	●	●							●	●	●					●	●			●	●					
CNMG120416MP	12,70	12,90	1,6									●	●						●	●									
CNMG160608MP	15,88	16,12	0,8									●	●	●					●	●									
CNMG160612MP	15,88	16,12	1,2									●	●	●					●	●			●	●					
CNMG160616MP	15,88	16,12	1,6									●	●	●					●	●									
CNMG190608MP	19,05	19,34	0,8									●	●	●					●	●									
CNMG190612MP	19,05	19,34	1,2									●	●	●					●	●			●	●					
CNMG190616MP	19,05	19,34	1,6									●	●						●	●									

Inserts

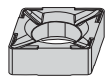

■ CNMG-RBB

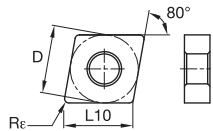

- first choice
- alternate choice

beyond **BLAST™**

ISO catalogue number	D mm	L10 mm	Re mm
CNMG120408RBB	12,70	12,90	0,8

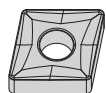

■ CNMG-RM

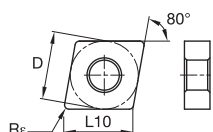

ISO catalogue number	D mm	L10 mm	Re mm
CNMG190612RM	19,05	19,34	1,2
CNMG190616RM	19,05	19,34	1,6
CNMG250924RM	25,40	25,79	2,4



■ CNMG-RN

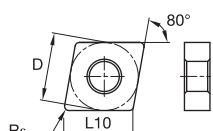

ISO catalogue number	D mm	L10 mm	Re mm
CNMG120408RN	12,70	12,90	0,8
CNMG120412RN	12,70	12,90	1,2
CNMG120416RN	12,70	12,90	1,6
CNMG160608RN	15,88	16,12	0,8
CNMG160612RN	15,88	16,12	1,2
CNMG160616RN	15,88	16,12	1,6
CNMG190608RN	19,05	19,34	0,8
CNMG190612RN	19,05	19,34	1,2
CNMG190616RN	19,05	19,34	1,6
CNMG190624RN	19,05	19,34	2,4

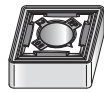

■ CNMG-RP

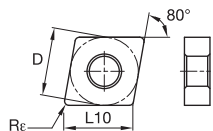

ISO catalogue number	D mm	L10 mm	Re mm
CNMG120404RP	12,70	12,90	0,4
CNMG120408RP	12,70	12,90	0,8
CNMG120412RP	12,70	12,90	1,2
CNMG120416RP	12,70	12,90	1,6
CNMG160608RP	15,88	16,12	0,8
CNMG160612RP	15,88	16,12	1,2
CNMG160616RP	15,88	16,12	1,6
CNMG190612RP	19,05	19,34	1,2
CNMG190616RP	19,05	19,34	1,6

	P	M	K	N	S	H	KCP05	KCP10	KCP25	KCP30	KCP40	KCK05	KCK15	KCK20	KCM15	KCM25	KCM35	KU10	K313	K68	KCS10	KCU10	KC5010	KC5510	KCU25	KC5025	KC5525	KC5410	KT315	KTP10			
CNMG120408RBB	●	●	●	●	●	●												●				●									●		
CNMG190612RM									●													●											
CNMG190616RM									●	●												●											
CNMG250924RM										●	●											●											
CNMG120408RN	●	●	●	●	●	●	●	●	●	●	●	●	●	●	●	●	●	●	●	●	●	●	●	●	●	●	●	●	●	●	●	●	
CNMG120412RN	●	●	●	●	●	●	●	●	●	●	●	●	●	●	●	●	●	●	●	●	●	●	●	●	●	●	●	●	●	●	●	●	
CNMG120416RN	●	●	●	●	●	●	●	●	●	●	●	●	●	●	●	●	●	●	●	●	●	●	●	●	●	●	●	●	●	●	●	●	
CNMG160608RN	●	●	●	●	●	●	●	●	●	●	●	●	●	●	●	●	●	●	●	●	●	●	●	●	●	●	●	●	●	●	●	●	
CNMG160612RN	●	●	●	●	●	●	●	●	●	●	●	●	●	●	●	●	●	●	●	●	●	●	●	●	●	●	●	●	●	●	●	●	
CNMG160616RN	●	●	●	●	●	●	●	●	●	●	●	●	●	●	●	●	●	●	●	●	●	●	●	●	●	●	●	●	●	●	●	●	
CNMG190608RN	●	●	●	●	●	●	●	●	●	●	●	●	●	●	●	●	●	●	●	●	●	●	●	●	●	●	●	●	●	●	●	●	
CNMG190612RN	●	●	●	●	●	●	●	●	●	●	●	●	●	●	●	●	●	●	●	●	●	●	●	●	●	●	●	●	●	●	●	●	
CNMG190616RN	●	●	●	●	●	●	●	●	●	●	●	●	●	●	●	●	●	●	●	●	●	●	●	●	●	●	●	●	●	●	●	●	
CNMG190624RN	●	●	●	●	●	●	●	●	●	●	●	●	●	●	●	●	●	●	●	●	●	●	●	●	●	●	●	●	●	●	●	●	
CNMG120404RP	●	●	●	●	●	●	●	●	●	●	●	●	●	●	●	●	●	●	●	●	●	●	●	●	●	●	●	●	●	●	●	●	
CNMG120408RP	●	●	●	●	●	●	●	●	●	●	●	●	●	●	●	●	●	●	●	●	●	●	●	●	●	●	●	●	●	●	●	●	
CNMG120412RP	●	●	●	●	●	●	●	●	●	●	●	●	●	●	●	●	●	●	●	●	●	●	●	●	●	●	●	●	●	●	●	●	
CNMG120416RP	●	●	●	●	●	●	●	●	●	●	●	●	●	●	●	●	●	●	●	●	●	●	●	●	●	●	●	●	●	●	●	●	
CNMG160608RP	●	●	●	●	●	●	●	●	●	●	●	●	●	●	●	●	●	●	●	●	●	●	●	●	●	●	●	●	●	●	●	●	
CNMG160612RP	●	●	●	●	●	●	●	●	●	●	●	●	●	●	●	●	●	●	●	●	●	●	●	●	●	●	●	●	●	●	●	●	
CNMG160616RP	●	●	●	●	●	●	●	●	●	●	●	●	●	●	●	●	●	●	●	●	●	●	●	●	●	●	●	●	●	●	●	●	
CNMG190612RP	●	●	●	●	●	●	●	●	●	●	●	●	●	●	●	●	●	●	●	●	●	●	●	●	●	●	●	●	●	●	●	●	
CNMG190616RP	●	●	●	●	●	●	●	●	●	●	●	●	●	●	●	●	●	●	●	●	●	●	●	●	●	●	●	●	●	●	●	●	

Inserts

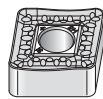

■ CNMM-RM

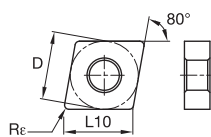

● first choice
○ alternate choice

ISO catalogue number	D mm	L10 mm	Re mm	KCP05	KCP10	KCP25	KCP30	KCP40	KCK05	KCK15	KCK20	KCM15	KCM25	KCM35	KU10	K313	K68	KCS10	KCU10	KC5010	KC5510	KCU25	KC5025	KC5525	KC5410	KT315	KTP10	
				P	M	K	N	S	H																			
CNMM120408RM	12,70	12,90	0,8	●	●	●	●	●																			●	●
CNMM120412RM	12,70	12,90	1,2	●	●	●	●	●																				
CNMM120416RM	12,70	12,90	1,6		●	●	●	●																				
CNMM160612RM	15,88	16,12	1,2		●	●	●	●																				
CNMM160616RM	15,88	16,12	1,6		●	●	●	●																				
CNMM160624RM	15,88	16,12	2,4		●	●	●	●																				
CNMM190612RM	19,05	19,34	1,2		●	●	●	●																				
CNMM190616RM	19,05	19,34	1,6		●	●	●	●																				
CNMM190624RM	19,05	19,34	2,4		●	●	●	●																				
CNMM250924RM	25,40	25,79	2,4		●	●	●	●																				



■ CNMM-RP

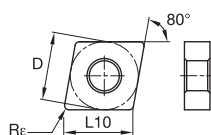

ISO catalogue number	D mm	L10 mm	Re mm	KCP05	KCP10	KCP25	KCP30	KCP40	KCK05	KCK15	KCK20	KCM15	KCM25	KCM35	KU10	K313	K68	KCS10	KCU10	KC5010	KC5510	KCU25	KC5025	KC5525	KC5410	KT315	KTP10		
				P	M	K	N	S	H																				
CNMM120408RP	12,70	12,90	0,8	●	●	●	●	●				●	●																
CNMM120412RP	12,70	12,90	1,2	●	●	●	●	●				●	●	●															
CNMM120416RP	12,70	12,90	1,6		●	●	●	●				●	●																
CNMM160608RP	15,88	16,12	0,8																										
CNMM160612RP	15,88	16,12	1,2	●	●	●	●	●				●	●	●															
CNMM160616RP	15,88	16,12	1,6	●	●	●	●	●				●	●	●															
CNMM190612RP	19,05	19,34	1,2		●	●	●	●				●	●	●															
CNMM190616RP	19,05	19,34	1,6		●	●	●	●				●	●	●															
CNMM190624RP	19,05	19,34	2,4		●	●	●	●				●	●																
CNMM250924RP	25,40	25,79	2,4		●	●	●	●																					



■ CNMP

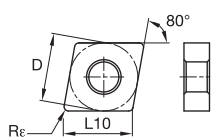

ISO catalogue number	D mm	L10 mm	Re mm	KCP05	KCP10	KCP25	KCP30	KCP40	KCK05	KCK15	KCK20	KCM15	KCM25	KCM35	KU10	K313	K68	KCS10	KCU10	KC5010	KC5510	KCU25	KC5025	KC5525	KC5410	KT315	KTP10					
				P	M	K	N	S	H																							
CNMP120404	12,70	12,90	0,4														●	●									●					
CNMP120408	12,70	12,90	0,8														●	●									●					
CNMP120412	12,70	12,90	1,2															●														
CNMP160608	15,88	16,12	0,8																●													
CNMP160612	15,88	16,12	1,2																●													
CNMP190608	19,05	19,34	0,8																●													
CNMP190612	19,05	19,34	1,2																●	●												



■ **CNMP-K**

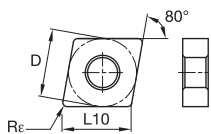

● first choice
○ alternate choice

	D	L10	Re
ISO catalogue number	mm	mm	mm
CNMP120404K	12,70	12,90	0,4
CNMP120408K	12,70	12,90	0,8
CNMP120412K	12,70	12,90	1,2



■ **CNMS**

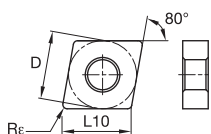

	D	L10	Re
ISO catalogue number	mm	mm	mm
CNMS120408	12,70	12,90	0,8
CNMS160608	15,88	16,12	0,8
CNMS190608	19,05	19,34	0,8
CNMS190612	19,05	19,34	1,2

Material	P	M	K	N	S	H	KCP05	KCP10	KCP25	KCP30	KCP40	KCK05	KCK15	KCK20	KCM15	KCM25	KCM35	KU10	K313	K68	KCS10	KCU10	KC5010	KC5510	KCU25	KC5025	KC5525	KC5410	KT315	KTP10
P	●	●	●	●	●	●																								
M	●	●	●	●	●	●																								
K	●	●	●	●	●	●																								
N	●	●	●	●	●	●																								
S	●	●	●	●	●	●																								
H	●	●	●	●	●	●																								



Inserts



Inserts

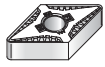

■ DNGG-FS

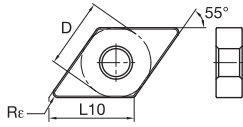

● first choice
○ alternate choice

ISO catalogue number	D mm	L10 mm	Re mm																									
				KCP05	KCP10	KCP25	KCP30	KCP40	KCK05	KCK15	KCK20	KCM15	KCM25	KCM35	KU10	K313	K68	KCS10	KCU10	KC5010	KC510	KCU25	KC5025	KC5525	KC5410	KT315	KTP10	
DNGG110402FS	9,52	11,63	0,2																									
DNGG110404FS	9,52	11,63	0,4																									
DNGG110408FS	9,52	11,63	0,8																									
DNGG150401FS	12,70	15,50	0,1																									
DNGG150402FS	12,70	15,50	0,2																									
DNGG150604FS	12,70	15,50	0,4																									
DNGG150404FS	12,70	15,50	0,4																									
DNGG150608FS	12,70	15,50	0,8																									
DNGG150408FS	12,70	15,50	0,8																									
DNGG150412FS	12,70	15,50	1,2																									
DNGG150416FS	12,70	15,50	1,6																									

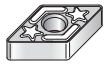

■ DNGG-LF

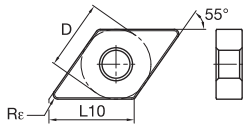

ISO catalogue number	D mm	L10 mm	Re mm																									
				KCP05	KCP10	KCP25	KCP30	KCP40	KCK05	KCK15	KCK20	KCM15	KCM25	KCM35	KU10	K313	K68	KCS10	KCU10	KC5010	KC510	KCU25	KC5025	KC5525	KC5410	KT315	KTP10	
DNGG150402LF	12,70	15,50	0,2																									
DNGG150404LF	12,70	15,50	0,4																									
DNGG150408LF	12,70	15,50	0,8																									

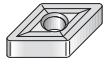

■ DNGP

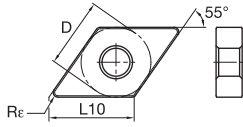

ISO catalogue number	D mm	L10 mm	Re mm																									
				KCP05	KCP10	KCP25	KCP30	KCP40	KCK05	KCK15	KCK20	KCM15	KCM25	KCM35	KU10	K313	K68	KCS10	KCU10	KC5010	KC510	KCU25	KC5025	KC5525	KC5410	KT315	KTP10	
DNGP150401	12,70	15,50	0,1																									
DNGP150402	12,70	15,50	0,2																									
DNGP150404	12,70	15,50	0,4																									
DNGP150408	12,70	15,50	0,8																									
DNGP150604	12,70	15,50	0,4																									
DNGP150608	12,70	15,50	0,8																									
DNGP150612	12,70	15,50	1,2																									

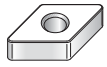
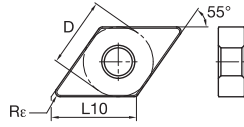

Inserts

■ DNMA

● first choice
○ alternate choice

ISO catalogue number	D mm	L10 mm	Re mm	P	M	K	N	S	H	KCP05	KCP10	KCP25	KCP30	KCP40	KCK05	KCK15	KCK20	KCM15	KCM25	KCM35	KU10	K313	K68	KCS10	KCU10	KC5010	KC5510	KCU25	KC5025	KC5525	KC5410	KT315	KTP10		
				DNMA110408	9,53	11,63	0,8	●	●	●	●																								
DNMA110412	9,53	11,63	1,2														●																		
DNMA150408	12,70	15,50	0,8												●	●	●																		
DNMA150412	12,70	15,50	1,2												●	●	●																		
DNMA150416	12,70	15,50	1,6												●	●	●																		
DNMA150608	12,70	15,50	0,8												●	●	●																		
DNMA150612	12,70	15,50	1,2												●	●	●																		
DNMA150616	12,70	15,50	1,6												●	●	●																		

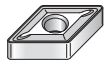
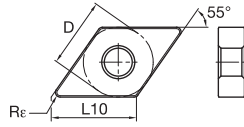
■ DNMG

ISO catalogue number	D mm	L10 mm	Re mm	P	M	K	N	S	H	KCP05	KCP10	KCP25	KCP30	KCP40	KCK05	KCK15	KCK20	KCM15	KCM25	KCM35	KU10	K313	K68	KCS10	KCU10	KC5010	KC5510	KCU25	KC5025	KC5525	KC5410	KT315	KTP10		
				DNMG150404B	12,70	15,50	0,4																					●							
DNMG150408B	12,70	15,50	0,8																					●	●										
DNMG150412B	12,70	15,50	1,2																					●											
DNMG150608B	12,70	15,50	0,8																					●											



Inserts



■ DNMG-CT

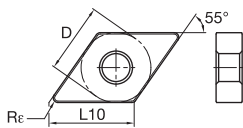

● first choice
○ alternate choice

ISO catalogue number	D mm	L10 mm	Re mm																								
				KCP05	KCP10	KCP25	KCP30	KCP40	KCK05	KCK15	KCK20	KCM15	KCM25	KCM35	KU10	K313	K68	KCS10	KCU10	KC5010	KC510	KCU25	KC5025	KC525	KC5410	KT315	KTP10
DNMG110404CT	9,53	11,63	0,4																								
DNMG110408CT	9,53	11,63	0,8	●	●														●	●							
DNMG150404CT	12,70	15,50	0,4	●	●	●													●	●							
DNMG150408CT	12,70	15,50	0,8	●	●	●													●	●							
DNMG150412CT	12,70	15,50	1,2		●														●	●							
DNMG150604CT	12,70	15,50	0,3		●														●	●							
DNMG150608CT	12,70	15,50	0,7	●	●	●													●	●							
DNMG150612CT	12,70	15,50	1,1	●	●	●													●	●							



■ DNMG-FF

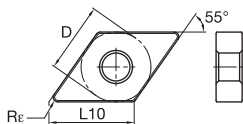

ISO catalogue number	D mm	L10 mm	Re mm																								
				KCP05	KCP10	KCP25	KCP30	KCP40	KCK05	KCK15	KCK20	KCM15	KCM25	KCM35	KU10	K313	K68	KCS10	KCU10	KC5010	KC510	KCU25	KC5025	KC525	KC5410	KT315	KTP10
DNMG110404FF	9,53	11,63	0,4	●	●														●	●							●
DNMG110408FF	9,53	11,63	0,8	●	●														●	●							●
DNMG150404FF	12,70	15,50	0,4	●	●														●	●							●
DNMG150408FF	12,70	15,50	0,8	●	●														●	●							●
DNMG150604FF	12,70	15,50	0,4	●	●														●	●							●
DNMG150608FF	12,70	15,50	0,8	●	●														●	●							●



■ DNMG-FN

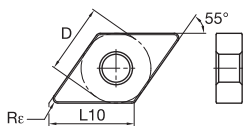

ISO catalogue number	D mm	L10 mm	Re mm																								
				KCP05	KCP10	KCP25	KCP30	KCP40	KCK05	KCK15	KCK20	KCM15	KCM25	KCM35	KU10	K313	K68	KCS10	KCU10	KC5010	KC510	KCU25	KC5025	KC525	KC5410	KT315	KTP10
DNMG110404FN	9,53	11,63	0,4	●	●	●																					●
DNMG110408FN	9,53	11,63	0,8	●	●	●																					●
DNMG110412FN	9,53	11,63	1,2	●	●																						●
DNMG150404FN	12,70	15,50	0,4	●	●	●																					●
DNMG150408FN	12,70	15,50	0,8	●	●	●																					●
DNMG150412FN	12,70	15,50	1,2	●	●																						●
DNMG150604FN	12,70	15,50	0,4	●	●	●																					●
DNMG150608FN	12,70	15,50	0,8	●	●	●																					●
DNMG150612FN	12,70	15,50	1,2	●	●	●																					●

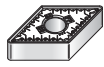

■ DNMG-FP

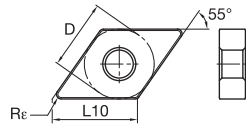

- first choice
- alternate choice

ISO catalogue number	D	L10	Re																								
	mm	mm	mm	KCP05	KCP10	KCP25	KCP30	KCP40	KCK05	KCK15	KCK20	KCM15	KCM25	KCM35	KU10	K313	K68	KCS10	KCU10	KC5010	KCU25	KC5025	KC525	KC5410	KT315	KTP10	
DNMG110404FP	9,53	11,63	0,4																								
DNMG110408FP	9,53	11,63	0,8	●								●								●	●						●
DNMG150404FP	12,70	15,50	0,4									●								●	●						●
DNMG150408FP	12,70	15,50	0,8	●	●							●								●	●						●
DNMG150412FP	12,70	15,50	1,2									●								●	●						●
DNMG150604FP	12,70	15,50	0,4									●								●	●						●
DNMG150608FP	12,70	15,50	0,8	●	●							●								●	●						●
DNMG150612FP	12,70	15,50	1,2									●								●	●						●

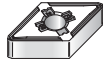

■ DNMG-FW

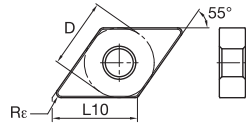

ISO catalogue number	D	L10	Re																								
	mm	mm	mm	KCP05	KCP10	KCP25	KCP30	KCP40	KCK05	KCK15	KCK20	KCM15	KCM25	KCM35	KU10	K313	K68	KCS10	KCU10	KC5010	KCU25	KC5025	KC525	KC5410	KT315	KTP10	
DNMG110404FW	9,53	11,63	0,4	●	●															●	●						●
DNMG110408FW	9,53	11,63	0,8	●	●																●	●					●
DNMG150404FW	12,70	15,50	0,4	●	●																●	●					●
DNMG150408FW	12,70	15,50	0,4	●	●																●	●					●
DNMG150604FW	12,70	15,50	0,4	●	●																●	●					●
DNMG150608FW	12,70	15,50	0,4	●	●																●	●					●



■ DNMG-MN

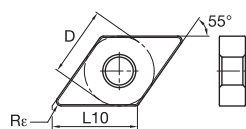

ISO catalogue number	D	L10	Re																								
	mm	mm	mm	KCP05	KCP10	KCP25	KCP30	KCP40	KCK05	KCK15	KCK20	KCM15	KCM25	KCM35	KU10	K313	K68	KCS10	KCU10	KC5010	KCU25	KC5025	KC525	KC5410	KT315	KTP10	
DNMG110404MN	9,53	11,63	0,4	●	●	●	●																				
DNMG110408MN	9,53	11,63	0,8	●	●	●	●																				
DNMG110412MN	9,53	11,63	1,2	●	●	●	●																				
DNMG150404MN	12,70	15,50	0,4	●	●	●	●																				
DNMG150408MN	12,70	15,50	0,8	●	●	●	●				●																
DNMG150412MN	12,70	15,50	1,2	●	●	●	●				●																
DNMG150416MN	12,70	15,50	1,6	●	●	●	●																				
DNMG150604MN	12,70	15,50	0,4	●	●	●	●																				
DNMG150608MN	12,70	15,50	0,8	●	●	●	●																				
DNMG150612MN	12,70	15,50	1,2	●	●	●	●																				
DNMG150616MN	12,70	15,50	1,6	●	●	●	●																				
DNMG190612MN	15,88	19,38	1,2	●	●		●																				



Inserts



■ DNMG-MP

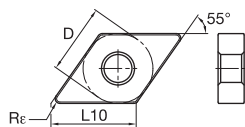

● first choice
○ alternate choice

ISO catalogue number	D mm	L10 mm	Re mm	Material Groups																							
				KCP05	KCP10	KCP25	KCP30	KCP40	KCK05	KCK15	KCK20	KCM15	KCM25	KCM35	KU10	K313	K68	KCS10	KCU10	KCS010	KCS510	KCU25	KCS025	KCS525	KCS410	KT315	KTP10
DNMG110408MP	9,53	11,63	0,8																								
DNMG110412MP	9,53	11,63	1,2																								
DNMG150404MP	12,70	15,50	0,4																								
DNMG150408MP	12,70	15,50	0,8	●	●																						
DNMG150412MP	12,70	15,50	1,2																								
DNMG150604MP	12,70	15,50	0,4																								
DNMG150608MP	12,70	15,50	0,8	●	●																						
DNMG150612MP	12,70	15,50	1,2	●																							

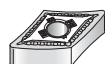

■ DNMG-MS

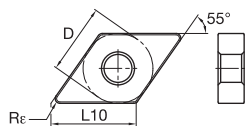

ISO catalogue number	D mm	L10 mm	Re mm	Material Groups																							
				KCP05	KCP10	KCP25	KCP30	KCP40	KCK05	KCK15	KCK20	KCM15	KCM25	KCM35	KU10	K313	K68	KCS10	KCU10	KCS010	KCS510	KCU25	KCS025	KCS525	KCS410	KT315	KTP10
DNMG110408MS	9,53	11,63	0,8														●			●		●	●		●		
DNMG150401MS	12,70	15,50	0,1																								
DNMG150402MS	12,70	15,50	0,2																								
DNMG150404MS	12,70	15,50	0,4														●			●		●	●		●		
DNMG150604MS	12,70	15,50	0,4														●			●		●	●		●		
DNMG150608MS	12,70	15,50	0,8														●			●		●	●		●		
DNMG150408MS	12,70	15,50	0,8														●			●		●	●		●		
DNMG150412MS	12,70	15,50	1,2														●			●		●	●		●		
DNMG150612MS	12,70	15,50	1,2														●			●		●	●		●		



■ DNMG-MW

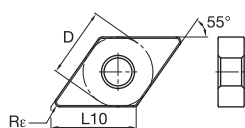

ISO catalogue number	D mm	L10 mm	Re mm	Material Groups																							
				KCP05	KCP10	KCP25	KCP30	KCP40	KCK05	KCK15	KCK20	KCM15	KCM25	KCM35	KU10	K313	K68	KCS10	KCU10	KCS010	KCS510	KCU25	KCS025	KCS525	KCS410	KT315	KTP10
DNMG150408MW	12,70	15,50	0,4	●	●	●																					
DNMG150412MW	12,70	15,50	1,2	●	●	●																					
DNMG150608MW	12,70	15,50	0,4	●	●	●																					
DNMG150612MW	12,70	15,50	1,2	●	●	●																					

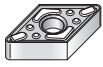
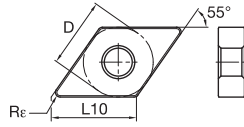

■ DNMG-P

● first choice
○ alternate choice

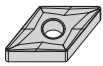
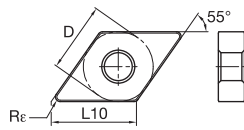
ISO catalogue number	D	L10	Re																									
	mm	mm	mm	KCP05	KCP10	KCP25	KCP30	KCP40	KCK05	KCK15	KCK20	KCM15	KCM25	KCM35	KU10	K313	K68	KCS10	KCU10	KCS010	KCS510	KCU25	KCS025	KCS525	KCS410	KT315	KTP10	
DNMG150404P	12,70	15,50	0,4																									
DNMG150408P	12,70	15,50	0,8														●			●	●							
DNMG150604P	12,70	15,50	0,4																		●	●						
DNMG150608P	12,70	15,50	0,8																	●	●							

■ DNMG-RM

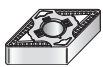
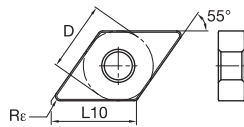
ISO catalogue number	D	L10	Re																									
	mm	mm	mm	KCP05	KCP10	KCP25	KCP30	KCP40	KCK05	KCK15	KCK20	KCM15	KCM25	KCM35	KU10	K313	K68	KCS10	KCU10	KCS010	KCS510	KCU25	KCS025	KCS525	KCS410	KT315	KTP10	
DNMG190608RM	15,88	19,38	0,8			●															●							
DNMG190612RM	15,88	19,38	1,2			●															●							

■ DNMG-RN

ISO catalogue number	D	L10	Re																									
	mm	mm	mm	KCP05	KCP10	KCP25	KCP30	KCP40	KCK05	KCK15	KCK20	KCM15	KCM25	KCM35	KU10	K313	K68	KCS10	KCU10	KCS010	KCS510	KCU25	KCS025	KCS525	KCS410	KT315	KTP10	
DNMG150408RN	12,70	15,50	0,8		●	●	●	●																				
DNMG150412RN	12,70	15,50	1,2		●	●	●	●																				
DNMG150416RN	12,70	15,50	1,6		●	●	●	●																				
DNMG150608RN	12,70	15,50	0,8	●	●	●	●	●																				
DNMG150612RN	12,70	15,50	1,2	●	●	●	●	●																				
DNMG150616RN	12,70	15,50	1,6	●	●	●	●	●																				
DNMG190608RN	15,88	19,38	0,8	●	●	●	●	●																				
DNMG190612RN	15,88	19,38	1,2	●	●	●	●	●																				



Inserts

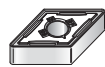

■ DNMG-RP

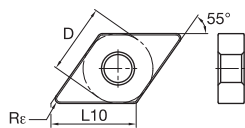

● first choice
○ alternate choice

ISO catalogue number	D mm	L10 mm	Re mm																								
				KCP05	KCP10	KCP25	KCP30	KCP40	KCK05	KCK15	KCK20	KCM15	KCM25	KCM35	KU10	K313	K68	KCS10	KCU10	KCS010	KCS510	KCU25	KCS025	KCS525	KCS410	KT315	KTP10
DNMG110408RP	9,53	11,63	0,8	●	●	●	●	●	●	●	●	●	●	●	●	●	●	●	●	●	●	●	●	●	●	●	●
DNMG110412RP	9,53	11,63	1,2	●	●	●	●	●	●	●	●	●	●	●	●	●	●	●	●	●	●	●	●	●	●	●	●
DNMG150408RP	12,70	15,50	0,8	●	●	●	●	●	●	●	●	●	●	●	●	●	●	●	●	●	●	●	●	●	●	●	●
DNMG150412RP	12,70	15,50	1,2	●	●	●	●	●	●	●	●	●	●	●	●	●	●	●	●	●	●	●	●	●	●	●	●
DNMG150416RP	12,70	15,50	1,6	●	●	●	●	●	●	●	●	●	●	●	●	●	●	●	●	●	●	●	●	●	●	●	●
DNMG150608RP	12,70	15,50	0,8	●	●	●	●	●	●	●	●	●	●	●	●	●	●	●	●	●	●	●	●	●	●	●	●
DNMG150612RP	12,70	15,50	1,2	●	●	●	●	●	●	●	●	●	●	●	●	●	●	●	●	●	●	●	●	●	●	●	●
DNMG150616RP	12,70	15,50	1,6	●	●	●	●	●	●	●	●	●	●	●	●	●	●	●	●	●	●	●	●	●	●	●	●



■ DNMG-UN

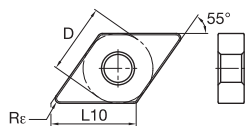

ISO catalogue number	D mm	L10 mm	Re mm																								
				KCP05	KCP10	KCP25	KCP30	KCP40	KCK05	KCK15	KCK20	KCM15	KCM25	KCM35	KU10	K313	K68	KCS10	KCU10	KCS010	KCS510	KCU25	KCS025	KCS525	KCS410	KT315	KTP10
DNMG110408UN	9,53	11,63	0,8							●	●	●															
DNMG110412UN	9,53	11,63	1,2							●	●	●															
DNMG150408UN	12,70	15,50	0,8							●	●	●															
DNMG150412UN	12,70	15,50	1,2							●	●	●															
DNMG150416UN	12,70	15,50	1,6							●	●	●															
DNMG150608UN	12,70	15,50	0,8							●	●	●															
DNMG150612UN	12,70	15,50	1,2							●	●	●															
DNMG150616UN	12,70	15,50	1,6							●	●	●															

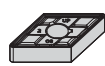

■ DNMG-UP

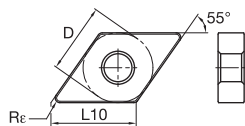

ISO catalogue number	D mm	L10 mm	Re mm																								
				KCP05	KCP10	KCP25	KCP30	KCP40	KCK05	KCK15	KCK20	KCM15	KCM25	KCM35	KU10	K313	K68	KCS10	KCU10	KCS010	KCS510	KCU25	KCS025	KCS525	KCS410	KT315	KTP10
DNMG110408UP	9,53	11,63	0,8										●	●													
DNMG110412UP	9,53	11,63	1,2										●	●													
DNMG150404UP	12,70	15,50	0,4										●	●													
DNMG150408UP	12,70	15,50	0,8										●	●													
DNMG150412UP	12,70	15,50	1,2										●	●													
DNMG150604UP	12,70	15,50	0,4										●	●													
DNMG150608UP	12,70	15,50	0,8										●	●													
DNMG150612UP	12,70	15,50	1,2										●	●													

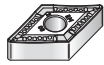
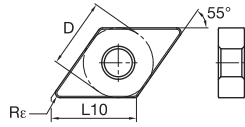

Inserts

■ DNMM-RM

 ● first choice
○ alternate choice

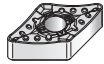
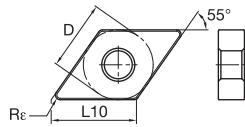
ISO catalogue number	D mm	L10 mm	Re mm	KCP05	KCP10	KCP25	KCP30	KCP40	KCK05	KCK15	KCK20	KCM15	KCM25	KCM35	KU10	K313	K68	KCS10	KCU10	KC5010	KC5510	KCU25	KC5025	KC5525	KC5410	KT315	KTP10
				DNMM150408RM	12,70	15,50	0,8																				
DNMM150412RM	12,70	15,50	1,2			●																					
DNMM150608RM	12,70	15,50	0,8	●	●	●	●																				
DNMM150612RM	12,70	15,50	1,2	●	●	●	●	●																			
DNMM150616RM	12,70	15,50	1,6	●	●																						

■ DNMM-RP

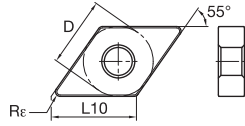
ISO catalogue number	D mm	L10 mm	Re mm	KCP05	KCP10	KCP25	KCP30	KCP40	KCK05	KCK15	KCK20	KCM15	KCM25	KCM35	KU10	K313	K68	KCS10	KCU10	KC5010	KC5510	KCU25	KC5025	KC5525	KC5410	KT315	KTP10
				DNMM150608RP	12,70	15,50	0,8	●	●								●										
DNMM150612RP	12,70	15,50	1,2	●	●								●														
DNMM150616RP	12,70	15,50	1,6	●	●																						

■ DNMP

ISO catalogue number	D mm	L10 mm	Re mm	KCP05	KCP10	KCP25	KCP30	KCP40	KCK05	KCK15	KCK20	KCM15	KCM25	KCM35	KU10	K313	K68	KCS10	KCU10	KC5010	KC5510	KCU25	KC5025	KC5525	KC5410	KT315	KTP10
				DNMP150404	12,70	15,50	0,4															●	●				
DNMP150408	12,70	15,50	0,8															●	●								
DNMP150412	12,70	15,50	1,2																●								

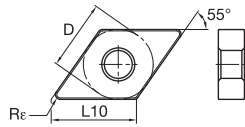
■ DNMP-K

ISO catalogue number	D mm	L10 mm	Re mm	KCP05	KCP10	KCP25	KCP30	KCP40	KCK05	KCK15	KCK20	KCM15	KCM25	KCM35	KU10	K313	K68	KCS10	KCU10	KC5010	KC5510	KCU25	KC5025	KC5525	KC5410	KT315	KTP10
				DNMP110408K	9,53	11,63	0,8	●																			
DNMP150404K	12,70	15,50	0,4																								
DNMP150408K	12,70	15,50	0,8																								
DNMP150412K	12,70	15,50	1,2																								
DNMP190608K	15,88	19,38	0,8																								

C2-C71	C72-C109	C110-C115	C116-C147	B10-B23	B24-B31	B32-B37

Inserts

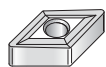

■ DNMS

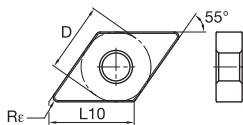

- first choice
- alternate choice

P	●	●	●	●	●																								●	●	
M	●	●	●	●	●																									●	●
K	●	●	●	●	●	●	●	●	●	●	●	●	●	●	●	●	●	●	●	●	●	●	●	●	●	●	●	●	●	●	●
N	●	●	●	●	●	●	●	●	●	●	●	●	●	●	●	●	●	●	●	●	●	●	●	●	●	●	●	●	●	●	●
S	●	●	●	●	●	●	●	●	●	●	●	●	●	●	●	●	●	●	●	●	●	●	●	●	●	●	●	●	●	●	●
H																															

			D	L10	Re	KCP05	KCP10	KCP25	KCP30	KCP40	KCK05	KCK15	KCK20	KCM15	KCM25	KCM35	KU10	K313	K68	KCS10	KCU10	KCS010	KCS510	KCU25	KCS025	KCS525	KCS410	KT315	KTP10
ISO catalogue number	mm	mm	mm																										
DNMS150408	12,70	15,50	0,8																										



■ RCGX-LF

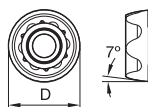

beyond BLAST™

			D	L10	Re																										
ISO catalogue number	mm	mm	mm																												
RCGX190600ELF	19,05	—	—																												



■ RNMA

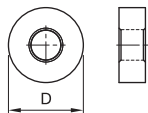

			D	L10	Re																										
ISO catalogue number	mm	mm	mm																												
RNMA090300	9,53	—	—																												
RNMA120400	12,70	—	—																												
RNMA150600	15,88	—	—																												
RNMA190600	19,05	—	—																												
RNMA250900	25,40	—	—																												



■ RNMG

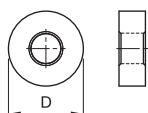

			D	L10	Re																										
ISO catalogue number	mm	mm	mm																												
RNMG190600	19,05	—	—																												
RNMG250900	25,40	—	—																												



■ RNMG-RN

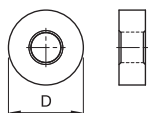

			D	L10	Re																										
ISO catalogue number	mm	mm	mm																												
RNMG090300RN	9,53	—	—																												
RNMG120400RN	12,70	—	—																												
RNMG150600RN	15,88	—	—																												
RNMG190600RN	19,05	—	—																												
RNMG250900RN	25,40	—	—																												



RNMG-UN

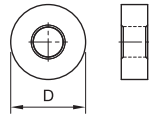

● first choice
○ alternate choice

P	●	●	●	●	●	●	●	●	●	●	●	●	●	●	●	●	●	●	●	●
M	●	●	●	●	●	●	●	●	●	●	●	●	●	●	●	●	●	●	●	●
K	●	●	●	●	●	●	●	●	●	●	●	●	●	●	●	●	●	●	●	●
N	●	●	●	●	●	●	●	●	●	●	●	●	●	●	●	●	●	●	●	●
S	●	●	●	●	●	●	●	●	●	●	●	●	●	●	●	●	●	●	●	●
H	●	●	●	●	●	●	●	●	●	●	●	●	●	●	●	●	●	●	●	●

ISO catalogue number	D	L10	R _e
	mm	mm	mm
RNMG120400UN	12,70	—	—



SNGG-FS

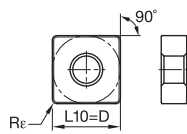

ISO catalogue number	D	L10	R _e
	mm	mm	mm
SNGG090308FS	9,53	9,53	0,8
SNGG120408FS	12,70	12,70	0,8



SNGG-LF

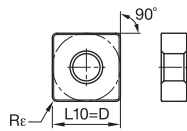

ISO catalogue number	D	L10	R _e
	mm	mm	mm
SNGG090308LF	9,53	9,53	0,8
SNGG120408LF	12,70	12,70	0,8
SNGG150612LF	15,88	15,88	1,2



SNGP

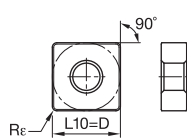

ISO catalogue number	D	L10	R _e
	mm	mm	mm
SNGP120404	12,70	12,70	0,4
SNGP120408	12,70	12,70	0,8



Inserts



■ SNMA

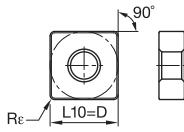

● first choice
○ alternate choice

ISO catalogue number	D	L10	Re																									
	mm	mm	mm	KCP05	KCP10	KCP25	KCP30	KCP40	KCK05	KCK15	KCK20	KCM15	KCM25	KCM35	KU10	K313	K68	KCS10	KGU10	KC5010	KC5510	KCU25	KC5025	KC5525	KC5410	KT315	KTP10	
SNMA120408	12,70	12,70	0,8																									
SNMA120412	12,70	12,70	1,2						●	●	●							●										
SNMA120416	12,70	12,70	1,6						●	●	●																	
SNMA150612	15,88	15,88	1,2						●	●	●																	
SNMA150616	15,88	15,88	1,6						●	●	●																	
SNMA190612	19,05	19,05	1,2						●	●	●							●										
SNMA190616	19,05	19,05	1,6						●	●	●							●										



■ SNMG

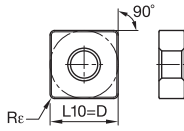

ISO catalogue number	D	L10	Re																									
	mm	mm	mm	KCP05	KCP10	KCP25	KCP30	KCP40	KCK05	KCK15	KCK20	KCM15	KCM25	KCM35	KU10	K313	K68	KCS10	KGU10	KC5010	KC5510	KCU25	KC5025	KC5525	KC5410	KT315	KTP10	
SNMG120408	12,70	12,70	0,8														●	●										
SNMG120412	12,70	12,70	1,2														●	●										
SNMG120416B	12,70	12,70	1,6														●	●										
SNMG190612	19,05	19,05	1,2			●		●									●	●	●	●								
SNMG190616B	19,05	19,05	1,6			●		●									●	●	●	●								
SNMG250924	25,40	25,40	2,4			●		●									●	●	●	●								



■ SNMG-FF

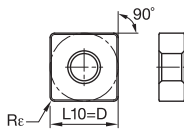

ISO catalogue number	D	L10	Re																									
	mm	mm	mm	KCP05	KCP10	KCP25	KCP30	KCP40	KCK05	KCK15	KCK20	KCM15	KCM25	KCM35	KU10	K313	K68	KCS10	KGU10	KC5010	KC5510	KCU25	KC5025	KC5525	KC5410	KT315	KTP10	
SNMG090304FF	9,53	9,53	0,4			●														●	●							●
SNMG090308FF	9,53	9,53	0,8			●														●	●							●
SNMG120404FF	12,70	12,70	0,4			●														●	●							●
SNMG120408FF	12,70	12,70	0,8			●														●	●							●



■ SNMG-FN

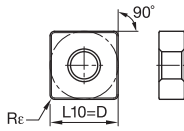

ISO catalogue number	D	L10	Re																									
	mm	mm	mm	KCP05	KCP10	KCP25	KCP30	KCP40	KCK05	KCK15	KCK20	KCM15	KCM25	KCM35	KU10	K313	K68	KCS10	KGU10	KC5010	KC5510	KCU25	KC5025	KC5525	KC5410	KT315	KTP10	
SNMG090304FN	9,53	9,53	0,4			●		●																				●
SNMG090308FN	9,53	9,53	0,8			●		●																				●
SNMG120404FN	12,70	12,70	0,4			●		●																				●
SNMG120408FN	12,70	12,70	0,8			●		●																				●
SNMG120412FN	12,70	12,70	1,2			●		●																				●
SNMG120416FN	12,70	12,70	1,6			●		●																				●

Inserts



■ SNMG-MP

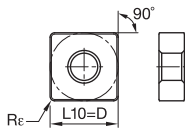

● first choice
○ alternate choice

	D	L10	Re
ISO catalogue number	mm	mm	mm
SNMG120408MP	12,70	12,70	0,8
SNMG120412MP	12,70	12,70	1,2
SNMG120416MP	12,70	12,70	1,6
SNMG150608MP	15,88	15,88	0,8
SNMG150612MP	15,88	15,88	1,2
SNMG150616MP	15,88	15,88	1,6
SNMG190612MP	19,05	19,05	1,2
SNMG190616MP	19,05	19,05	1,6



■ SNMG-MS

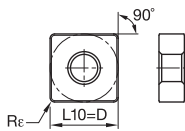

	D	L10	Re
ISO catalogue number	mm	mm	mm
SNMG120408MS	12,70	12,70	0,8
SNMG120412MS	12,70	12,70	1,2
SNMG150608MS	15,88	15,88	0,8
SNMG150612MS	15,88	15,88	1,2
SNMG190612MS	19,05	19,05	1,2



■ SNMG-MW

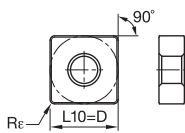

	D	L10	Re
ISO catalogue number	mm	mm	mm
SNMG120408MW	12,70	12,70	0,8
SNMG120412MW	12,70	12,70	1,2



■ SNMG-P

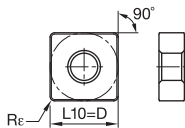

	D	L10	Re
ISO catalogue number	mm	mm	mm
SNMG120408P	12,70	12,70	0,8
SNMG120412P	12,70	12,70	1,2

	P	M	K	N	S	H	KCP05	KCP10	KCP25	KCP30	KCP40	KCK05	KCK15	KCK20	KCM15	KCM25	KCM35	KU10	K313	K68	KCS10	KCU10	KCS010	KCS510	KCU25	KCS025	KCS525	KCS410	KT315	KTP10
SNMG-MP	●	●	●	●	●	●	●	●	●	●	●	●	●	●	●	●	●	●	●	●	●	●	●	●	●	●	●	●	●	●
SNMG-MS	●	●	●	●	●	●	●	●	●	●	●	●	●	●	●	●	●	●	●	●	●	●	●	●	●	●	●	●	●	●
SNMG-MW	●	●	●	●	●	●	●	●	●	●	●	●	●	●	●	●	●	●	●	●	●	●	●	●	●	●	●	●	●	●
SNMG-P	●	●	●	●	●	●	●	●	●	●	●	●	●	●	●	●	●	●	●	●	●	●	●	●	●	●	●	●	●	●

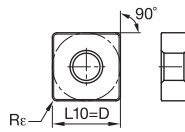

■ SNMG-RM

● first choice
○ alternate choice

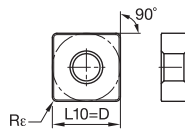
ISO catalogue number	D mm	L10 mm	Rr mm																							
				KCP05	KCP10	KCP25	KCP30	KCP40	KCK05	KCK15	KCK20	KCM15	KCM25	KCM35	KU10	K313	K68	KCS10	KCU10	KC5010	KC5510	KCU25	KC5025	KC5525	KC5410	KT315
SNMG190612RM	19,05	19,05	1,2															●	●							
SNMG190616RM	19,05	19,05	1,6			●	●											●								
SNMG250924RM	25,40	25,40	2,4			●		●											●							

■ SNMG-RN

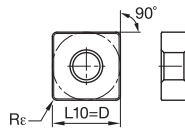
ISO catalogue number	D mm	L10 mm	Rr mm																							
				KCP05	KCP10	KCP25	KCP30	KCP40	KCK05	KCK15	KCK20	KCM15	KCM25	KCM35	KU10	K313	K68	KCS10	KCU10	KC5010	KC5510	KCU25	KC5025	KC5525	KC5410	KT315
SNMG090412RN	9,53	9,53	1,2	●																						
SNMG120408RN	12,70	12,70	0,8	●	●	●	●																			
SNMG120412RN	12,70	12,70	1,2	●	●	●	●																			
SNMG120416RN	12,70	12,70	1,6	●	●	●	●																			
SNMG150608RN	15,88	15,88	0,8	●	●	●	●																			
SNMG150612RN	15,88	15,88	1,2	●	●	●	●																			
SNMG150616RN	15,88	15,88	1,6	●	●	●	●																			
SNMG190608RN	19,05	19,05	0,8	●	●	●	●																			
SNMG190612RN	19,05	19,05	1,2	●	●	●	●																			
SNMG190616RN	19,05	19,05	1,6	●	●	●	●																			
SNMG190624RN	19,05	19,05	2,4		●	●																				
SNMG250924RN	25,40	25,40	2,4		●	●																				

■ SNMG-RP

ISO catalogue number	D mm	L10 mm	Rr mm																							
				KCP05	KCP10	KCP25	KCP30	KCP40	KCK05	KCK15	KCK20	KCM15	KCM25	KCM35	KU10	K313	K68	KCS10	KCU10	KC5010	KC5510	KCU25	KC5025	KC5525	KC5410	KT315
SNMG120408RP	12,70	12,70	0,8	●	●	●	●	●	●	●	●	●	●	●	●	●	●	●	●	●	●	●	●	●	●	●
SNMG120412RP	12,70	12,70	1,2	●	●	●	●	●	●	●	●	●	●	●	●	●	●	●	●	●	●	●	●	●	●	●
SNMG120416RP	12,70	12,70	1,6	●	●	●	●	●	●	●	●	●	●	●	●	●	●	●	●	●	●	●	●	●	●	●
SNMG150612RP	15,88	15,88	1,2	●	●	●	●	●	●	●	●	●	●	●	●	●	●	●	●	●	●	●	●	●	●	●
SNMG150616RP	15,88	15,88	1,6	●	●	●	●	●	●	●	●	●	●	●	●	●	●	●	●	●	●	●	●	●	●	●
SNMG190612RP	19,05	19,05	1,2	●	●	●	●	●	●	●	●	●	●	●	●	●	●	●	●	●	●	●	●	●	●	●
SNMG190616RP	19,05	19,05	1,6	●	●	●	●	●	●	●	●	●	●	●	●	●	●	●	●	●	●	●	●	●	●	●

C2-C71	C72-C109	C110-C115	C116-C147	B10-B23	B24-B31	B32-B37

Inserts



■ SNMG-UN

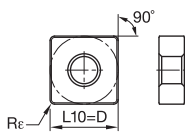

● first choice
○ alternate choice

ISO catalogue number	D	L10	Re
	mm	mm	mm
SNMG120408UN	12,70	12,70	0,8
SNMG120412UN	12,70	12,70	1,2
SNMG120416UN	12,70	12,70	1,6
SNMG150612UN	15,88	15,88	1,2
SNMG150616UN	15,88	15,88	1,6
SNMG190612UN	19,05	19,05	1,2
SNMG190616UN	19,05	19,05	1,6



■ SNMG-UP

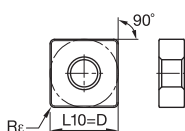

ISO catalogue number	D	L10	Re
	mm	mm	mm
SNMG120408UP	12,70	12,70	0,8
SNMG120412UP	12,70	12,70	1,2
SNMG120416UP	12,70	12,70	1,6
SNMG150612UP	15,88	15,88	1,2
SNMG190612UP	19,05	19,05	1,2



■ SNMM-RH

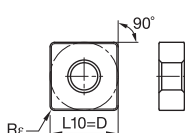

ISO catalogue number	D	L10	Re
	mm	mm	mm
SNMM190612RH	19,05	19,05	1,2
SNMM190616RH	19,05	19,05	1,6
SNMM190624RH	19,05	19,05	2,4
SNMM250724RH	25,40	25,40	2,4
SNMM250732RH	25,40	25,40	3,2
SNMM250924RH	25,40	25,40	2,4

	P	M	K	N	S	H	KCP05	KCP10	KCP25	KCP30	KCP40	KCK05	KCK15	KCK20	KCM15	KCM25	KCM35	KU10	K313	K68	KCS10	KCU10	KC5010	KC5510	KCU25	KC5025	KC5525	KC6410	KT315	KTP10	
SNMG-UN	●	●	●	●	●	●						●	●	●																	
SNMG-UP																															
SNMM-RH																															



■ SNMM-RM

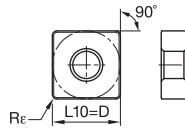

● first choice
○ alternate choice

P	●	●	●	●																				●	●	
M	●																									
K																										
N																										
S																										
H																										

ISO catalogue number	D	L10	Re	KCP05	KCP10	KCP25	KCP30	KCP40	KCK05	KCK15	KCK20	KCM15	KCM25	KCM35	KU10	K313	K68	KCS10	KCU10	KCS010	KCS510	KCU25	KCS025	KCS525	KCS410	KT315	KTP10	
	mm	mm	mm																									
SNMM120408RM	12,70	12,70	0,8																									
SNMM120412RM	12,70	12,70	1,2			●																						
SNMM120416RM	12,70	12,70	1,6			●	●																					
SNMM150612RM	15,88	15,88	1,2		●	●																						
SNMM150616RM	15,88	15,88	1,6		●	●	●																					
SNMM190612RM	19,05	19,05	1,2		●	●	●	●																				
SNMM190616RM	19,05	19,05	1,6		●	●	●																					
SNMM190624RM	19,05	19,05	2,4		●	●	●																					
SNMM250724RM	25,40	25,40	2,4		●	●	●																					
SNMM250924RM	25,40	25,40	2,4		●	●	●	●																				



■ SNMM-RP

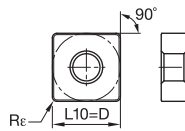

ISO catalogue number	D	L10	Re	KCP05	KCP10	KCP25	KCP30	KCP40	KCK05	KCK15	KCK20	KCM15	KCM25	KCM35	KU10	K313	K68	KCS10	KCU10	KCS010	KCS510	KCU25	KCS025	KCS525	KCS410	KT315	KTP10	
	mm	mm	mm																									
SNMM120408RP	12,70	12,70	0,8			●						●	●	●														
SNMM120412RP	12,70	12,70	1,2			●						●	●	●														
SNMM150612RP	15,88	15,88	1,2			●						●	●	●														
SNMM150616RP	15,88	15,88	1,6		●							●	●	●														
SNMM190612RP	19,05	19,05	1,2			●						●	●	●														
SNMM190616RP	19,05	19,05	1,6			●						●	●	●														
SNMM190624RP	19,05	19,05	2,4			●						●	●	●														
SNMM250724RP	25,40	25,40	2,4			●						●	●	●														
SNMM250924RP	25,40	25,40	2,4			●						●	●	●														



■ SNMP

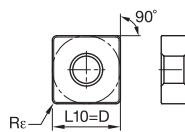

ISO catalogue number	D	L10	Re	KCP05	KCP10	KCP25	KCP30	KCP40	KCK05	KCK15	KCK20	KCM15	KCM25	KCM35	KU10	K313	K68	KCS10	KCU10	KCS010	KCS510	KCU25	KCS025	KCS525	KCS410	KT315	KTP10	
	mm	mm	mm																									
SNMP120408	12,70	12,70	0,8																									
SNMP150612	15,88	15,88	1,2																									
SNMP190612	19,05	19,05	1,2																									

C2-C71	C72-C109	C110-C115	C116-C147	B10-B23	B24-B31	B32-B37

Inserts



■ SNMP-K

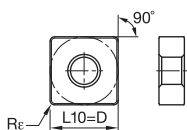

● first choice
○ alternate choice

ISO catalogue number	D mm	L10 mm	Re mm
SNMP120408K	12,70	12,70	0,8



■ SNMS

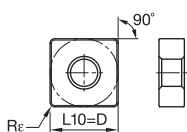

ISO catalogue number	D mm	L10 mm	Re mm
SNMS120408	12,70	12,70	0,8
SNMS120412	12,70	12,70	1,2
SNMS190612	19,05	19,05	1,2



■ TNGG-FS

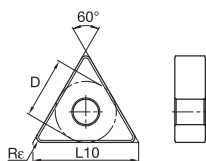

ISO catalogue number	D mm	L10 mm	Re mm
TNGG160402FS	9,53	16,50	0,2
TNGG160404FS	9,53	16,50	0,4
TNGG160408FS	9,53	16,50	0,8
TNGG220408FS	12,70	22,00	0,8



■ TNGG-LF

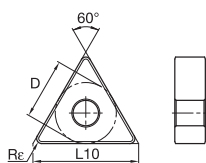

ISO catalogue number	D mm	L10 mm	Re mm
TNGG160402LF	9,53	16,50	0,2
TNGG160404LF	9,53	16,50	0,4
TNGG160408LF	9,53	16,50	0,8

	P	M	K	N	S	H	KCP05	KCP10	KCP25	KCP30	KCP40	KCK05	KCK15	KCK20	KCM15	KCM25	KCM35	KU10	K313	K68	KCS10	KCU10	KCS010	KCS510	KCU25	KCS025	KCS525	KCS410	KT315	KTP10			
SNMP-K	●	●	●	●	●	●	●	●	●																								
SNMS																																	
TNGG-FS																																	
TNGG-LF																																	

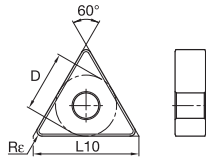

TNGP

● first choice
○ alternate choice

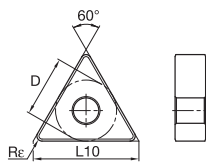
ISO catalogue number	D mm	L10 mm	Re mm	Material Groups																					
				KCP05	KCP10	KCP25	KCP30	KCP40	KCK05	KCK15	KCK20	KCM15	KCM25	KCM35	KU10	K313	K68	KCS10	KCU10	KC5010	KCU25	KC5025	KC5525	KC5410	KT315
TNGP160402	9,53	16,50	0,2																						
TNGP160404	9,53	16,50	0,4															●	●						
TNGP160408	9,53	16,50	0,8															●	●					●	

TNMA

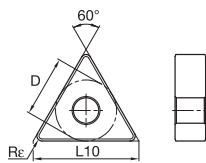
ISO catalogue number	D mm	L10 mm	Re mm	Material Groups																					
				KCP05	KCP10	KCP25	KCP30	KCP40	KCK05	KCK15	KCK20	KCM15	KCM25	KCM35	KU10	K313	K68	KCS10	KCU10	KC5010	KCU25	KC5025	KC5525	KC5410	KT315
TNMA160408	9,53	16,50	0,8						●	●	●						●								
TNMA160412	9,53	16,50	1,2						●	●	●														
TNMA160416	9,53	16,50	1,6						●	●	●														
TNMA220408	12,70	22,00	0,8						●	●	●						●								
TNMA220412	12,70	22,00	1,2						●	●	●						●								
TNMA220416	12,70	22,00	1,6						●	●	●														
TNMA270616	15,88	27,50	1,6						●	●							●								

TNMG

ISO catalogue number	D mm	L10 mm	Re mm	Material Groups																					
				KCP05	KCP10	KCP25	KCP30	KCP40	KCK05	KCK15	KCK20	KCM15	KCM25	KCM35	KU10	K313	K68	KCS10	KCU10	KC5010	KCU25	KC5025	KC5525	KC5410	KT315
TNMG160408B	9,53	16,50	0,8														●								
TNMG160412	9,53	16,50	1,2														●								
TNMG220408	12,70	22,00	0,8														●								
TNMG220412	12,70	22,00	1,2														●								
TNMG220416	12,70	22,00	1,6														●								
TNMG330924	19,05	33,00	2,4			●		●												●					



Inserts



■ TNMG-CT

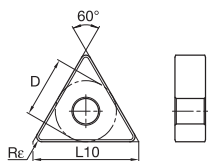

● first choice
○ alternate choice

	D	L10	Re
ISO catalogue number	mm	mm	mm
TNMG220408CT	12,70	22,00	0,8
TNMG220412CT	12,70	22,00	1,2



■ TNMG-FF

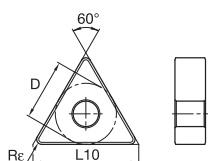

	D	L10	Re
ISO catalogue number	mm	mm	mm
TNMG110304FF	6,35	11,00	0,4
TNMG110308FF	6,35	11,00	0,8
TNMG160404FF	9,53	16,50	0,4
TNMG160408FF	9,53	16,50	0,8



■ TNMG-FN

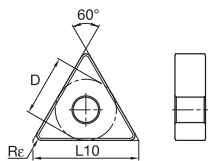

	D	L10	Re
ISO catalogue number	mm	mm	mm
TNMG110304FN	6,35	11,00	0,4
TNMG110308FN	6,35	11,00	0,8
TNMG160404FN	9,53	16,50	0,4
TNMG160408FN	9,53	16,50	0,8
TNMG160412FN	9,53	16,50	1,2
TNMG220404FN	12,70	22,00	0,4
TNMG220408FN	12,70	22,00	0,8
TNMG220412FN	12,70	22,00	1,2



■ TNMG-FP

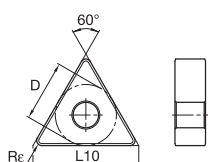

	D	L10	Re
ISO catalogue number	mm	mm	mm
TNMG160404FP	9,53	16,50	0,4
TNMG160408FP	9,53	16,50	0,8
TNMG160412FP	9,53	16,50	1,2
TNMG220404FP	12,70	22,00	0,4
TNMG220408FP	12,70	22,00	0,8

	P	M	K	N	S	H	KCP05	KCP10	KCP25	KCP30	KCP40	KCK05	KCK15	KCK20	KCM15	KCM25	KCM35	KU10	K313	K68	KCS10	KCU10	KC5010	KC5510	KCU25	KC5025	KC5525	KC5410	KT315	KTP10															
TNMG220408CT	●	●	●	●	●																																								
TNMG220412CT	●	●					●	●															●																						
TNMG110304FF																							●	●																					
TNMG110308FF																							●	●																					
TNMG160404FF							●	●															●	●									●	●											
TNMG160408FF							●	●															●	●									●	●											
TNMG110304FN								●	●			●																									●								
TNMG110308FN								●	●			●																																	
TNMG160404FN							●	●	●			●																																	
TNMG160408FN							●	●	●			●																																	
TNMG160412FN							●	●	●			●																																	
TNMG220404FN								●	●			●																																	
TNMG220408FN							●	●	●																																				
TNMG220412FN								●	●																																				
TNMG160404FP								●								●							●	●																					
TNMG160408FP								●								●							●	●																					
TNMG160412FP																●							●	●																					
TNMG220404FP																●							●	●																					
TNMG220408FP																●							●	●																					

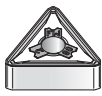

■ TNMG-FW

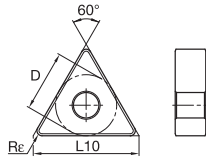

● first choice
○ alternate choice

ISO catalogue number	D mm	L10 mm	Re mm	Material Groups																							
				KCP05	KCP10	KCP25	KCP30	KCP40	KCK05	KCK15	KCK20	KCM15	KCM25	KCM35	KU10	K313	K68	KCS10	KCU10	KC5010	KC5510	KCU25	KC5025	KC5525	KC5410	KT315	KTP10
TNMG160404FW	9,53	16,50	0,2	●	●																						
TNMG160408FW	9,53	16,50	0,4	●	●																						
TNMG160412FW	9,53	16,50	1,2	●	●																						



■ TNMG-MN

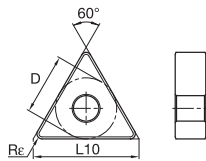

ISO catalogue number	D mm	L10 mm	Re mm	Material Groups																							
				KCP05	KCP10	KCP25	KCP30	KCP40	KCK05	KCK15	KCK20	KCM15	KCM25	KCM35	KU10	K313	K68	KCS10	KCU10	KC5010	KC5510	KCU25	KC5025	KC5525	KC5410	KT315	KTP10
TNMG160404MN	9,53	16,50	0,4	●	●	●	●																				
TNMG160408MN	9,53	16,50	0,8	●	●	●	●																				
TNMG160412MN	9,53	16,50	1,2	●	●	●	●																				
TNMG220404MN	12,70	22,00	0,4	●	●	●	●																				
TNMG220408MN	12,70	22,00	0,8	●	●	●	●																				
TNMG220412MN	12,70	22,00	1,2	●	●	●	●																				
TNMG220416MN	12,70	22,00	1,6			●																					



■ TNMG-MP

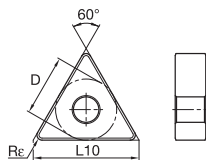

ISO catalogue number	D mm	L10 mm	Re mm	Material Groups																							
				KCP05	KCP10	KCP25	KCP30	KCP40	KCK05	KCK15	KCK20	KCM15	KCM25	KCM35	KU10	K313	K68	KCS10	KCU10	KC5010	KC5510	KCU25	KC5025	KC5525	KC5410	KT315	KTP10
TNMG160404MP	9,53	16,50	0,4																								
TNMG160408MP	9,53	16,50	0,8		●	●																					
TNMG160412MP	9,53	16,50	1,2																								
TNMG220408MP	12,70	22,00	0,8																								
TNMG220412MP	12,70	22,00	1,2																								
TNMG220416MP	12,70	22,00	1,6																								



Inserts



■ TNMG-MS

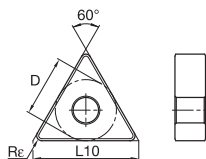

● first choice
○ alternate choice

ISO catalogue number	D mm	L10 mm	Re mm	KCP05	KCP10	KCP25	KCP30	KCP40	KCK05	KCK15	KCK20	KCM15	KCM25	KCM35	KU10	K313	K68	KCS10	KCU10	KCS010	KCS510	KCU25	KCS025	KCS525	KCS410	KT315	KTP10
				TNMG160402MS	9,53	16,50	0,2																				
TNMG160404MS	9,53	16,50	0,4													●			●		●	●		●			
TNMG160408MS	9,53	16,50	0,8																●		●	●		●			
TNMG220404MS	12,70	22,00	0,4																	●		●	●		●		
TNMG220408MS	12,70	22,00	0,8													●			●		●	●		●			
TNMG220412MS	12,70	22,00	1,2													●			●		●	●		●			
TNMG270608MS	15,88	27,50	0,8													●					●	●		●			
TNMG270616MS	15,88	27,50	1,6													●					●	●		●			

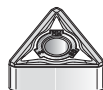

■ TNMG-MW

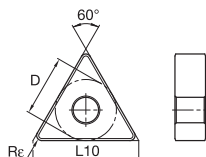

ISO catalogue number	D mm	L10 mm	Re mm	KCP05	KCP10	KCP25	KCP30	KCP40	KCK05	KCK15	KCK20	KCM15	KCM25	KCM35	KU10	K313	K68	KCS10	KCU10	KCS010	KCS510	KCU25	KCS025	KCS525	KCS410	KT315	KTP10	
				TNMG160408MW	9,53	16,50	0,8	●	●	●																		
TNMG160412MW	9,53	16,50	1,2	●	●	●																						



■ TNMG-P

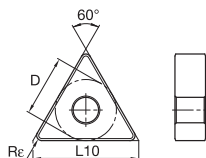

ISO catalogue number	D mm	L10 mm	Re mm	KCP05	KCP10	KCP25	KCP30	KCP40	KCK05	KCK15	KCK20	KCM15	KCM25	KCM35	KU10	K313	K68	KCS10	KCU10	KCS010	KCS510	KCU25	KCS025	KCS525	KCS410	KT315	KTP10
				TNMG160404P	9,53	16,50	0,4																	●	●		
TNMG160408P	9,53	16,50	0,8													●			●	●							
TNMG220404P	12,70	22,00	0,4																	●	●						
TNMG220408P	12,70	22,00	0,8																	●	●						
TNMG220412P	12,70	22,00	1,2																	●	●					●	

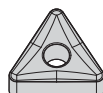

■ TNMG-RM

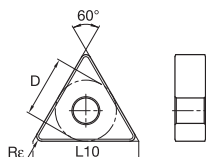

ISO catalogue number	D mm	L10 mm	Re mm	KCP05	KCP10	KCP25	KCP30	KCP40	KCK05	KCK15	KCK20	KCM15	KCM25	KCM35	KU10	K313	K68	KCS10	KCU10	KCS010	KCS510	KCU25	KCS025	KCS525	KCS410	KT315	KTP10
				TNMG330924RM	19,05	32,99	2,4			●	●													●			

Inserts



■ TNMG-UP

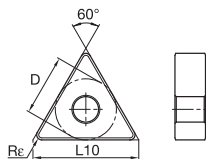

● first choice
○ alternate choice

ISO catalogue number	D mm	L10 mm	Re mm	Material Groups																					
				KCP05	KCP10	KCP25	KCP30	KCP40	KCK05	KCK15	KCK20	KCM15	KCM25	KCM35	KU10	K313	K68	KCS10	KCU10	KC5010	KC5510	KC5025	KC5525	KC5410	KT315
TNMG160404UP	9,53	16,50	0,4																						
TNMG160408UP	9,53	16,50	0,8																						
TNMG160412UP	9,53	16,50	1,2																						
TNMG220408UP	12,70	22,00	0,8																						
TNMG220412UP	12,70	22,00	1,2																						

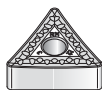

■ TNMM-RM

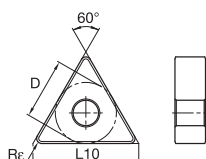

ISO catalogue number	D mm	L10 mm	Re mm	Material Groups																					
				KCP05	KCP10	KCP25	KCP30	KCP40	KCK05	KCK15	KCK20	KCM15	KCM25	KCM35	KU10	K313	K68	KCS10	KCU10	KC5010	KC5510	KC5025	KC5525	KC5410	KT315
TNMM160408RM	9,53	16,50	0,8																						
TNMM160412RM	9,53	16,50	1,2																						
TNMM220408RM	12,70	22,00	0,8																						
TNMM220412RM	12,70	22,00	1,2																						
TNMM220416RM	12,70	22,00	1,6																						
TNMM270612RM	15,88	27,50	1,2																						
TNMM270616RM	15,88	27,50	1,6																						

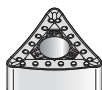

■ TNMM-RP

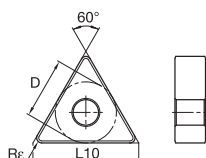

ISO catalogue number	D mm	L10 mm	Re mm	Material Groups																					
				KCP05	KCP10	KCP25	KCP30	KCP40	KCK05	KCK15	KCK20	KCM15	KCM25	KCM35	KU10	K313	K68	KCS10	KCU10	KC5010	KC5510	KC5025	KC5525	KC5410	KT315
TNMM160408RP	9,53	16,50	0,8																						
TNMM160412RP	9,53	16,50	1,2																						
TNMM220408RP	12,70	22,00	0,8																						
TNMM220412RP	12,70	22,00	1,2																						
TNMM220416RP	12,70	22,00	1,6																						
TNMM270616RP	15,88	27,50	1,6																						



■ TNMP

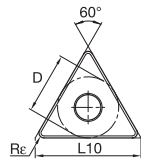

● first choice
○ alternate choice



P	●	●	●	●	●																	●	●	
M	●																							
K	●																							
N	●																							
S																								
H																								

ISO catalogue number	D	L10	Re	KCP05	KCP10	KCP25	KCP30	KCP40	KCK05	KCK15	KCK20	KCM15	KCM25	KCM35	KU10	K313	K68	KCS10	KCU10	KC5010	KC5510	KCU25	KC5025	KC5525	KC5410	KT315	KTP10
	mm	mm	mm																								
TNMP160404	9,53	16,50	0,4																								
TNMP160408	9,53	16,50	0,8															●	●								
TNMP160416	9,53	16,50	1,6																●								
TNMP220404	12,70	22,00	0,4																●								
TNMP220408	12,70	22,00	0,8																●								
TNMP220412	12,70	22,00	1,2																●							●	
TNMP220416	12,70	22,00	1,6																●								
TNMP220424	12,70	22,00	2,4																●								

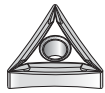

■ TNMP-K

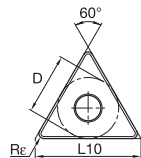

ISO catalogue number	D	L10	Re																							
	mm	mm	mm																							
TNMP160404K	9,53	16,50	0,4			●																				
TNMP160408K	9,53	16,50	0,8		●	●																				
TNMP220408K	12,70	22,00	0,8			●																				

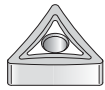

■ TNMS

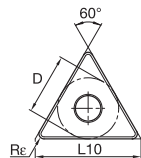

ISO catalogue number	D	L10	Re																							
	mm	mm	mm																							
TNMS160404	9,53	16,50	0,4															●								●
TNMS160408	9,53	16,50	0,8															●								●
TNMS220404	12,70	22,00	0,4															●								●
TNMS220408	12,70	22,00	0,8															●								●
TNMS220412	12,70	22,00	1,2															●								●
TNMS270608	15,88	27,50	0,8															●								●

						
C2-C71	C72-C109	C110-C115	C116-C147	B10-B23	B24-B31	B32-B37

Inserts



■ VNGG-FS

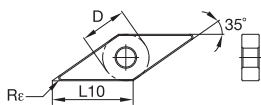

● first choice
○ alternate choice

	D	L10	Re	P	M	K	N	S	H
ISO catalogue number	mm	mm	mm						
VNGG160401FS	9,53	16,61	0,1	●	●	●	●	●	●
VNGG160402FS	9,53	16,61	0,2				●	●	●
VNGG160404FS	9,53	16,61	0,4					●	●
VNGG160408FS	9,53	16,61	0,8					●	●
VNGG160412FS	9,53	16,61	1,2					●	●



■ VNGG-LF

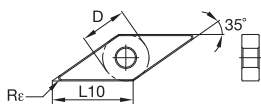

	D	L10	Re	P	M	K	N	S	H
ISO catalogue number	mm	mm	mm						
VNGG160402LF	9,53	16,61	0,2				●	●	●
VNGG160404LF	9,53	16,61	0,4				●	●	●
VNGG160408LF	9,53	16,61	0,8				●	●	●
VNGG220408LF	12,70	22,14	0,8				●	●	●



■ VNGP

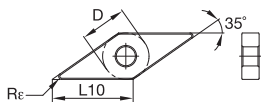

	D	L10	Re	P	M	K	N	S	H
ISO catalogue number	mm	mm	mm						
VNGP160401	9,53	16,61	0,1				●	●	●
VNGP160402	9,53	16,61	0,2				●	●	●
VNGP220404	12,70	22,14	0,4				●	●	●
VNGP220408	12,70	22,14	0,8				●	●	●
VNGP220412	12,70	22,14	1,2				●	●	●

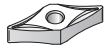

■ **VNMG-K**

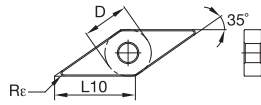

● first choice
○ alternate choice

ISO catalogue number	D mm	L10 mm	R _e mm	Material Compatibility Legend																														
				P	M	K	N	S	H	KCP05	KCP10	KCP25	KCP30	KCP40	KCK05	KCK15	KCK20	KCM15	KCM25	KCM35	KU10	K313	K68	KCS10	KCU10	KC5010	KCU25	KCU510	KC5025	KC5525	KC5410	KT315	KTP10	
				●	●	●	●	●								●	●	●				●	●	●	●	●	●	●	●	●	●	●	●	●
VNMG160404K	9,53	16,61	0,4																															
VNMG160408K	9,53	16,61	0,8																															

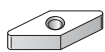

■ **VNMA**

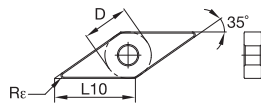

ISO catalogue number	D mm	L10 mm	R _e mm	Material Compatibility Legend																														
VNMA160408	9,53	16,61	0,8																															
VNMA160408	9,53	16,61	0,8																															



■ **VNMG**

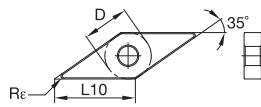

ISO catalogue number	D mm	L10 mm	R _e mm	Material Compatibility Legend																															
VNMG160408	9,53	16,61	0,8																																
VNMG160412	9,53	16,61	1,2																																
VNMG220408	12,70	22,14	0,8																																
VNMG220412	12,70	22,14	1,2																																



■ **VNMG-FF**

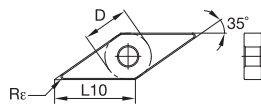

ISO catalogue number	D mm	L10 mm	R _e mm	Material Compatibility Legend																														
VNMG160404FF	9,53	16,61	0,4	●	●																													
VNMG160408FF	9,53	16,61	0,8	●	●																													



Inserts



■ VNMG-FN

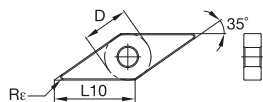

● first choice
○ alternate choice

ISO catalogue number	D mm	L10 mm	Re mm																					
				KCP05	KCP10	KCP25	KCP30	KCP40	KCK05	KCK15	KCK20	KCM15	KCM25	KCM35	KU10	K313	K68	KCS10	KCU10	KC5010	KCU25	KC5025	KC5525	KC5410
VNMG160404FN	9,53	16,61	0,4	●	●	●	●	●	●	●	●	●	●	●	●	●	●	●	●	●	●	●	●	●
VNMG160408FN	9,53	16,61	0,8	●	●	●	●	●	●	●	●	●	●	●	●	●	●	●	●	●	●	●	●	●



■ VNMG-FP

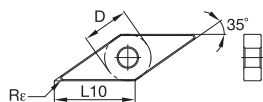

ISO catalogue number	D mm	L10 mm	Re mm																					
				KCP05	KCP10	KCP25	KCP30	KCP40	KCK05	KCK15	KCK20	KCM15	KCM25	KCM35	KU10	K313	K68	KCS10	KCU10	KC5010	KCU25	KC5025	KC5525	KC5410
VNMG160404FP	9,53	16,61	0,4	●	●	●	●	●	●	●	●	●	●	●	●	●	●	●	●	●	●	●	●	●
VNMG160408FP	9,53	16,61	0,8	●	●	●	●	●	●	●	●	●	●	●	●	●	●	●	●	●	●	●	●	●



■ VNMG-MN

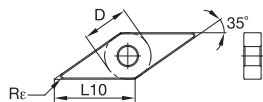

ISO catalogue number	D mm	L10 mm	Re mm																					
				KCP05	KCP10	KCP25	KCP30	KCP40	KCK05	KCK15	KCK20	KCM15	KCM25	KCM35	KU10	K313	K68	KCS10	KCU10	KC5010	KCU25	KC5025	KC5525	KC5410
VNMG160404MN	9,53	16,61	0,4	●	●	●	●	●	●	●	●	●	●	●	●	●	●	●	●	●	●	●	●	●
VNMG160408MN	9,53	16,61	0,8	●	●	●	●	●	●	●	●	●	●	●	●	●	●	●	●	●	●	●	●	●
VNMG160412MN	9,53	16,61	1,2	●	●	●	●	●	●	●	●	●	●	●	●	●	●	●	●	●	●	●	●	●



■ VNMG-MP

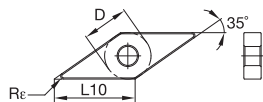

ISO catalogue number	D mm	L10 mm	Re mm																					
				KCP05	KCP10	KCP25	KCP30	KCP40	KCK05	KCK15	KCK20	KCM15	KCM25	KCM35	KU10	K313	K68	KCS10	KCU10	KC5010	KCU25	KC5025	KC5525	KC5410
VNMG160404MP	9,53	16,61	0,4	●	●	●	●	●	●	●	●	●	●	●	●	●	●	●	●	●	●	●	●	●
VNMG160408MP	9,53	16,61	0,8	●	●	●	●	●	●	●	●	●	●	●	●	●	●	●	●	●	●	●	●	●
VNMG160412MP	9,53	16,61	1,2	●	●	●	●	●	●	●	●	●	●	●	●	●	●	●	●	●	●	●	●	●



■ VNMG-MS

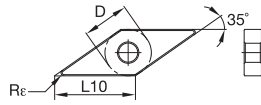

- first choice
- alternate choice

ISO catalogue number	D mm	L10 mm	Re mm																								
				KCP05	KCP10	KCP25	KCP30	KCP40	KCK05	KCK15	KCK20	KCM15	KCM25	KCM35	KU10	K313	K68	KCS10	KCU10	KC5010	KC5510	KCU25	KC5025	KC5525	KC5410	KT315	KTP10
VNMG160401MS	9,53	16,61	0,1																								
VNMG160402MS	9,53	16,61	0,2															●									
VNMG160404MS	9,53	16,61	0,4															●									
VNMG160408MS	9,53	16,61	0,8															●									
VNMG220404MS	12,70	22,14	0,4																								
VNMG220408MS	12,70	22,14	0,8																								

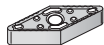

■ VNMG-P

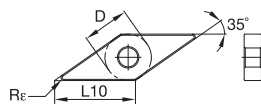

ISO catalogue number	D mm	L10 mm	Re mm																								
				KCP05	KCP10	KCP25	KCP30	KCP40	KCK05	KCK15	KCK20	KCM15	KCM25	KCM35	KU10	K313	K68	KCS10	KCU10	KC5010	KC5510	KCU25	KC5025	KC5525	KC5410	KT315	KTP10
VNMG160404P	9,53	16,61	0,4															●									
VNMG160408P	9,53	16,61	0,8															●									

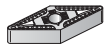

■ VNMG-RN

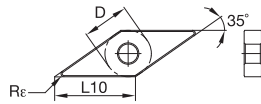

ISO catalogue number	D mm	L10 mm	Re mm																								
				KCP05	KCP10	KCP25	KCP30	KCP40	KCK05	KCK15	KCK20	KCM15	KCM25	KCM35	KU10	K313	K68	KCS10	KCU10	KC5010	KC5510	KCU25	KC5025	KC5525	KC5410	KT315	KTP10
VNMG160408RN	9,53	16,61	0,8	●	●																						
VNMG160412RN	9,53	16,61	1,2	●	●																						
VNMG220408RN	12,70	22,14	0,8	●	●	●	●																				
VNMG220412RN	12,70	22,14	1,2	●	●	●	●																				



■ VNMG-RP

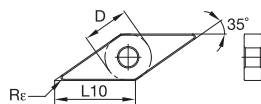

ISO catalogue number	D mm	L10 mm	Re mm																								
				KCP05	KCP10	KCP25	KCP30	KCP40	KCK05	KCK15	KCK20	KCM15	KCM25	KCM35	KU10	K313	K68	KCS10	KCU10	KC5010	KC5510	KCU25	KC5025	KC5525	KC5410	KT315	KTP10
VNMG160408RP	9,53	16,61	0,8	●	●					●	●	●															●
VNMG160412RP	9,53	16,61	1,2	●	●					●	●	●	●														●



C2-C71 | C72-C109 | C110-C115 | C116-C147 | B10-B23 | B24-B31 | B32-B37

Inserts

VNMG-UN

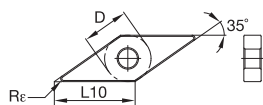

● first choice
○ alternate choice

ISO catalogue number	D mm	L10 mm	Re mm
VNMG160404UN	9,53	16,61	0,4
VNMG160408UN	9,53	16,61	0,8

VNMG-UP

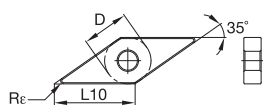

ISO catalogue number	D mm	L10 mm	Re mm
VNMG160404UP	9,53	16,61	0,4
VNMG160408UP	9,53	16,61	0,8
VNMG160412UP	9,53	16,61	1,2

VNMP

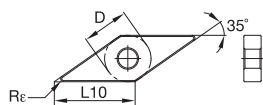

ISO catalogue number	D mm	L10 mm	Re mm
VNMP160404	9,53	16,61	0,4
VNMP160408	9,53	16,61	0,8

VNMP-K

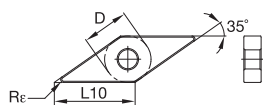

ISO catalogue number	D mm	L10 mm	Re mm
VNMP160404K	9,53	16,61	0,4
VNMP160408K	9,53	16,61	0,8

VNMS

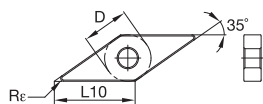

ISO catalogue number	D mm	L10 mm	Re mm
VNMS160404	9,53	16,61	0,4
VNMS160408	9,53	16,61	0,8

	P	M	K	N	S	H	KCP05	KCP10	KCP25	KCP30	KCP40	KCK05	KCK15	KCK20	KCM15	KCM25	KCM35	KU10	K313	K68	KCS10	KCU10	KC5010	KC5510	KCU25	KC5025	KC5525	KC5410	KT315	KTP10	
VNMG-UN	●	●	●	●	●	●						●	●	●																	
VNMG-UP															●	●						●	●								
VNMP																				●	●										
VNMP-K									●	●											●										
VNMS																					●								●		

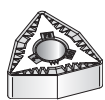

■ WNGG-FS

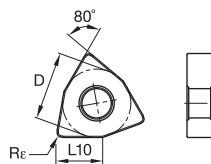

- first choice
- alternate choice

ISO catalogue number	D	L10	Re
mm	mm	mm	mm
WNGG080404FS	12,70	8,69	0,4
WNGG080408FS	12,70	8,69	0,8



■ WNGG-LF

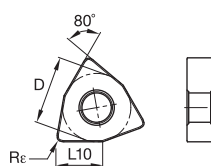

ISO catalogue number	D	L10	Re
mm	mm	mm	mm
WNGG080401LF	12,70	8,69	0,1
WNGG080402LF	12,70	8,69	0,2
WNGG080404LF	12,70	8,69	0,4
WNGG080408LF	12,70	8,69	0,8

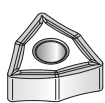

■ WNGP-K

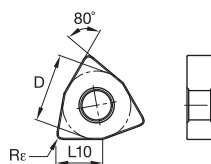

ISO catalogue number	D	L10	Re
mm	mm	mm	mm
WNGP080408K	12,70	8,69	0,8

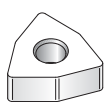

■ WNMA

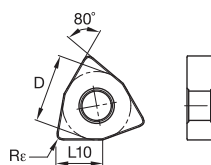

ISO catalogue number	D	L10	Re
mm	mm	mm	mm
WNMA060408	9,53	6,52	0,8
WNMA060412	9,53	6,52	1,2
WNMA080408	12,70	8,69	0,8
WNMA080412	12,70	8,69	1,2
WNMA080416	12,70	8,69	1,6

	P	M	K	N	S	H	KCP05	KCP10	KCP25	KCP30	KCP40	KCK05	KCK15	KCK20	KCM15	KCM25	KCM35	KU10	K313	K68	KCS10	KCU10	KC5010	KC5510	KCU25	KC5025	KC5525	KC5410	KT315	KTP10	
WNGG-FS	●	●	●	●	●	●																									
WNGG-LF																						●	●								
WNGP-K																															●
WNMA												●	●	●																	

C2-C71	C72-C109	C110-C115	C116-C147	B10-B23	B24-B31	B32-B37

Inserts



■ WNMG-FF

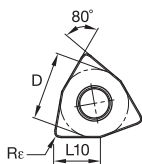

● first choice
○ alternate choice

ISO catalogue number	D	L10	Re
	mm	mm	mm
WNMG060404FF	9,53	6,52	0,4
WNMG060408FF	9,53	6,52	0,8
WNMG080404FF	12,70	8,69	0,4
WNMG080408FF	12,70	8,69	0,8

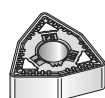

■ WNMG-FN

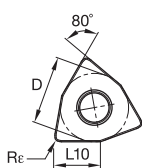

ISO catalogue number	D	L10	Re
	mm	mm	mm
WNMG060404FN	9,53	6,52	0,4
WNMG060408FN	9,53	6,52	0,8
WNMG080404FN	12,70	8,69	0,4
WNMG080408FN	12,70	8,69	0,8
WNMG080412FN	12,70	8,69	1,2



■ WNMG-FP

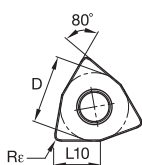

ISO catalogue number	D	L10	Re
	mm	mm	mm
WNMG060404FP	9,53	6,52	0,4
WNMG060408FP	9,53	6,52	0,8
WNMG080404FP	12,70	8,69	0,4
WNMG080408FP	12,70	8,69	0,8
WNMG080412FP	12,70	8,69	1,2

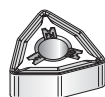

■ WNMG-FW

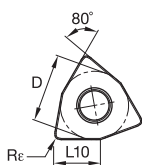

ISO catalogue number	D	L10	Re
	mm	mm	mm
WNMG060404FW	9,53	6,52	0,4
WNMG060408FW	9,53	6,52	0,8
WNMG060412FW	9,53	6,52	1,2
WNMG080404FW	12,70	8,69	0,4
WNMG080408FW	12,70	8,69	0,8
WNMG080412FW	12,70	8,69	1,2

P	M	K	N	S	H	KCP05	KCP10	KCP25	KCP30	KCP40	KCK05	KCK15	KCK20	KCM15	KCM25	KCM35	KU10	K313	K68	KCS10	KCU10	KC5010	KC5510	KCU25	KC5025	KC5525	KC5410	KT315	KTP10
●	●	●	●	●	●																								
●	●	●	●	●	●																								
●	●	●	●	●	●																								
●	●	●	●	●	●																								
●	●	●	●	●	●																								

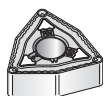

■ WNMG-MN

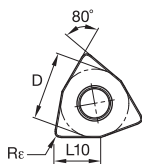

● first choice
○ alternate choice

P	●	●	●	●	●																			●	●
M	●											●	●				●	●							●
K											●	●	●												●
N																								●	
S																									
H																									

ISO catalogue number	D	L10	Re																									
	mm	mm	mm	KCP05	KCP10	KCP25	KCP30	KCP40	KCK05	KCK15	KCK20	KCM15	KCM25	KCM35	KU10	K313	K68	KCS10	KCU10	KC5010	KC5510	KCU25	KC5025	KC5525	KC5410	KT315	KTP10	
WNMG060404MN	9,53	6,52	0,4																									
WNMG060408MN	9,53	6,52	0,8	●	●	●																						
WNMG060412MN	9,53	6,52	1,2	●	●	●																						
WNMG080408MN	12,70	8,69	0,8	●	●	●	●																					
WNMG080412MN	12,70	8,69	1,2	●	●	●		●																				
WNMG080416MN	12,70	8,69	1,6			●																						



■ WNMG-MP

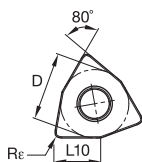

ISO catalogue number	D	L10	Re																									
	mm	mm	mm	KCP05	KCP10	KCP25	KCP30	KCP40	KCK05	KCK15	KCK20	KCM15	KCM25	KCM35	KU10	K313	K68	KCS10	KCU10	KC5010	KC5510	KCU25	KC5025	KC5525	KC5410	KT315	KTP10	
WNMG060404MP	9,53	6,52	0,4									●	●															
WNMG060408MP	9,53	6,52	0,8	●	●							●	●	●						●	●							
WNMG060412MP	9,53	6,52	1,2									●																
WNMG080408MP	12,70	8,69	0,8	●	●							●	●	●						●	●							
WNMG080412MP	12,70	8,69	1,2	●								●	●	●						●	●							

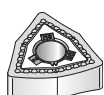

■ WNMG-MS

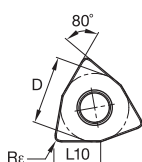

ISO catalogue number	D	L10	Re																									
	mm	mm	mm	KCP05	KCP10	KCP25	KCP30	KCP40	KCK05	KCK15	KCK20	KCM15	KCM25	KCM35	KU10	K313	K68	KCS10	KCU10	KC5010	KC5510	KCU25	KC5025	KC5525	KC5410	KT315	KTP10	
WNMG060408MS	9,53	6,52	0,8																									
WNMG080401MS	12,70	8,69	0,1																									
WNMG080402MS	12,70	8,69	0,2																									
WNMG080404MS	12,70	8,69	0,4																									
WNMG080408MS	12,70	8,69	0,8																									



Inserts

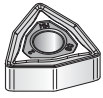

■ WNMG-MW

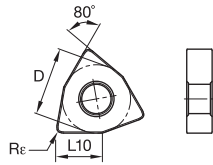

● first choice
○ alternate choice

	D	L10	Re
ISO catalogue number	mm	mm	mm
WNMG060408MW	9,53	6,52	0,8
WNMG060412MW	9,53	6,52	1,2
WNMG080408MW	12,70	8,69	0,8
WNMG080412MW	12,70	8,69	1,2

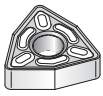

■ WNMG-P

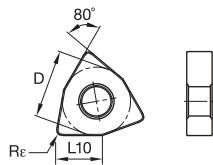

	D	L10	Re
ISO catalogue number	mm	mm	mm
WNMG080404P	12,70	8,69	0,4
WNMG080408P	12,70	8,69	0,8

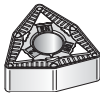

■ WNMG-RN

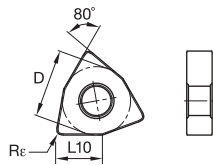

	D	L10	Re
ISO catalogue number	mm	mm	mm
WNMG060408RN	9,53	6,52	0,8
WNMG060412RN	9,53	6,52	1,2
WNMG080408RN	12,70	8,69	0,8
WNMG080412RN	12,70	8,69	1,2
WNMG080416RN	12,70	8,69	1,6

	P	M	K	N	S	H	KCP05	KCP10	KCP25	KCP30	KCP40	KCK05	KCK15	KCK20	KCM15	KCM25	KCM35	KU10	K313	K68	KCS10	KCU10	KC5010	KCU25	KC5510	KC5025	KC5525	KC5410	KT315	KTP10
WNMG060408MW	●	●	●	●	●	●	●	●	●	●	●	●	●	●	●	●	●	●	●	●	●	●	●	●	●	●	●	●	●	●
WNMG060412MW	●	●	●	●	●	●	●	●	●	●	●	●	●	●	●	●	●	●	●	●	●	●	●	●	●	●	●	●	●	●
WNMG080408MW	●	●	●	●	●	●	●	●	●	●	●	●	●	●	●	●	●	●	●	●	●	●	●	●	●	●	●	●	●	●
WNMG080412MW	●	●	●	●	●	●	●	●	●	●	●	●	●	●	●	●	●	●	●	●	●	●	●	●	●	●	●	●	●	●
WNMG080404P																						●	●							
WNMG080408P																						●	●					●		
WNMG060408RN							●	●																						
WNMG060412RN							●	●																						
WNMG080408RN							●	●	●	●	●																			
WNMG080412RN							●	●	●	●	●																			
WNMG080416RN							●	●	●																					

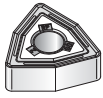
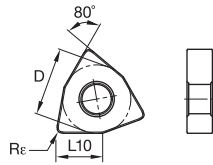

WNMG-RP

● first choice
○ alternate choice

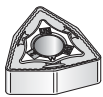
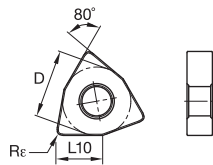
ISO catalogue number	D mm	L10 mm	Re mm	Material Groups																						
				KCP05	KCP10	KCP25	KCP30	KCP40	KCK05	KCK15	KCK20	KCM15	KCM25	KCM35	KU10	K313	K68	KCS10	KCU10	KC5010	KC5510	KCU25	KC5025	KC5525	KC5410	KT315
WNMG060408RP	9,53	6,52	0,8	●	●	●	●	●	●	●	●	●	●	●	●	●	●	●	●	●	●	●	●	●	●	●
WNMG060412RP	9,53	6,52	1,2	●	●	●	●	●	●	●	●	●	●	●	●	●	●	●	●	●	●	●	●	●	●	●
WNMG080408RP	12,70	8,69	0,8	●	●	●	●	●	●	●	●	●	●	●	●	●	●	●	●	●	●	●	●	●	●	●
WNMG080412RP	12,70	8,69	1,2	●	●	●	●	●	●	●	●	●	●	●	●	●	●	●	●	●	●	●	●	●	●	●
WNMG080416RP	12,70	8,69	1,6	●	●	●	●	●	●	●	●	●	●	●	●	●	●	●	●	●	●	●	●	●	●	●

WNMG-UN

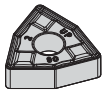
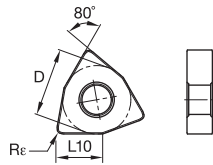
ISO catalogue number	D mm	L10 mm	Re mm	Material Groups																						
				KCP05	KCP10	KCP25	KCP30	KCP40	KCK05	KCK15	KCK20	KCM15	KCM25	KCM35	KU10	K313	K68	KCS10	KCU10	KC5010	KC5510	KCU25	KC5025	KC5525	KC5410	KT315
WNMG060404UN	9,53	6,52	0,4							●	●	●														
WNMG060408UN	9,53	6,52	0,8							●	●	●														
WNMG060412UN	9,53	6,52	1,2							●	●	●														
WNMG080404UN	12,70	8,69	0,4							●	●	●														
WNMG080408UN	12,70	8,69	0,8							●	●	●														
WNMG080412UN	12,70	8,69	1,2							●	●	●														
WNMG080416UN	12,70	8,69	1,6							●	●															

MG-UP

ISO catalogue number	D mm	L10 mm	Re mm	Material Groups																						
				KCP05	KCP10	KCP25	KCP30	KCP40	KCK05	KCK15	KCK20	KCM15	KCM25	KCM35	KU10	K313	K68	KCS10	KCU10	KC5010	KC5510	KCU25	KC5025	KC5525	KC5410	KT315
WNMG060408UP	9,53	6,52	0,8																							
WNMG080408UP	12,70	8,69	0,8																							
WNMG080412UP	12,70	8,69	1,2																							



Inserts

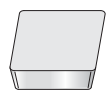

■ CPGN

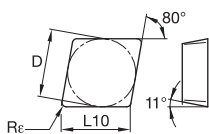

● first choice
○ alternate choice

ISO catalogue number	D	L10	Re	KCP05	KGP10	KCP25	KCP30	KCP40	KCK05	KCK15	KCK20	KCM15	KCM25	KCM35	KUJ10	K313	K68	KCS10	KCU10	KC5010	KC5510	KCU25	KC5025	KC5525	KC5410	KT315	KTP10
	mm	mm	mm																								
CPGN120304	12,70	12,90	0,4													●	●										
CPGN120308	12,70	12,90	0,8													●	●										

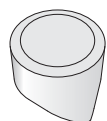

■ RCGV

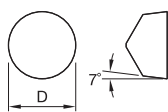

ISO catalogue number	D	L10	Re	KCP05	KGP10	KCP25	KCP30	KCP40	KCK05	KCK15	KCK20	KCM15	KCM25	KCM35	KUJ10	K313	K68	KCS10	KCU10	KC5010	KC5510	KCU25	KC5025	KC5525	KC5410	KT315	KTP10
	mm	mm	mm																								
RCGV060400	6,35	—	—													●			●	●							
RCGV090700	9,53	—	—													●			●	●							
RCGV120700	12,70	—	—													●			●	●							

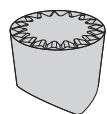

■ RCGV-MP

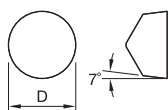

ISO catalogue number	D	L10	Re	KCP05	KGP10	KCP25	KCP30	KCP40	KCK05	KCK15	KCK20	KCM15	KCM25	KCM35	KUJ10	K313	K68	KCS10	KCU10	KC5010	KC5510	KCU25	KC5025	KC5525	KC5410	KT315	KTP10
	mm	mm	mm																								
RCGX060400MP	6,35	—	—																●								
RCGX090700MP	9,53	—	—																●								
RCGX120700MP	12,70	—	—																●								

Inserts



■ SPGR-K

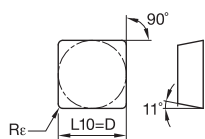

● first choice
○ alternate choice

ISO catalogue number	D mm	L10 mm	Re mm	P	M	K	N	S	H	KCP05	KCP10	KCP25	KCP30	KCP40	KCK05	KCK15	KCK20	KCM15	KCM25	KCM35	KU10	K313	K68	KCS10	KCU10	KC5010	KC5510	KCU25	KC5025	KC5525	KC5410	KT315	KTP10				
				●	●	●	●	●	●	●	●	●	●	●	●	●	●	●	●	●	●	●	●	●	●	●	●	●	●	●	●	●	●	●	●	●	●
SPGR090308K	9,53	9,53	0,8																																		
SPGR120308K	12,70	12,70	0,8																																		



■ SPUN

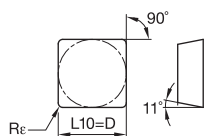

ISO catalogue number	D mm	L10 mm	Re mm	P	M	K	N	S	H	KCP05	KCP10	KCP25	KCP30	KCP40	KCK05	KCK15	KCK20	KCM15	KCM25	KCM35	KU10	K313	K68	KCS10	KCU10	KC5010	KC5510	KCU25	KC5025	KC5525	KC5410	KT315	KTP10				
				●	●	●	●	●	●	●	●	●	●	●	●	●	●	●	●	●	●	●	●	●	●	●	●	●	●	●	●	●	●	●	●	●	●
SPUN120304	12,70	12,70	0,4																																		
SPUN120308	12,70	12,70	0,8																																		
SPUN120312	12,70	12,70	1,2																																		
SPUN190412	19,05	19,05	1,2																																		



■ TPGN

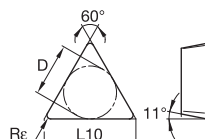

ISO catalogue number	D mm	L10 mm	Re mm	P	M	K	N	S	H	KCP05	KCP10	KCP25	KCP30	KCP40	KCK05	KCK15	KCK20	KCM15	KCM25	KCM35	KU10	K313	K68	KCS10	KCU10	KC5010	KC5510	KCU25	KC5025	KC5525	KC5410	KT315	KTP10				
				●	●	●	●	●	●	●	●	●	●	●	●	●	●	●	●	●	●	●	●	●	●	●	●	●	●	●	●	●	●	●	●	●	●
TPGN060104	3,97	6,88	0,4																																		
TPGN110304	6,35	11,00	0,4																																		
TPGN110308	6,35	11,00	0,8																																		
TPGN160302	9,53	16,50	0,2																																		
TPGN160304	9,53	16,50	0,4																																		
TPGN160308	9,53	16,50	0,8																																		
TPGN160312	9,53	16,50	1,2																																		
TPGN160316	9,53	16,50	1,6																																		
TPGN220404	12,70	22,00	0,4																																		
TPGN220408	12,70	22,00	0,8																																		
TPGN220412	12,70	22,00	1,2																																		
TPGN220416	12,70	22,00	1,6																																		
TPGN220432	12,70	22,00	3,2																																		

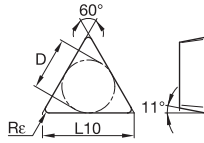

● first choice
○ alternate choice

P	●	●	●	●	●																				●	●
M	●																									
K	●																									
N	●																									
S	●																									
H																										

ISO catalogue number	D	L10	Re																									
	mm	mm	mm	KCP05	KCP10	KCP25	KCP30	KCP40	KCK05	KCK15	KCK20	KCM15	KCM25	KCM35	KU10	K313	K68	KCS10	KCU10	KC5010	KC5510	KCU25	KC5025	KC5525	KC5410	KT315	KTP10	
TPGR110304K	6,35	11,00	0,4																									
TPGR110308K	6,35	11,00	0,8																									
TPGR160304K	9,53	16,50	0,4																									
TPGR160308K	9,53	16,50	0,8																									
TPGR220404K	12,70	22,00	0,4																									
TPGR220408K	12,70	22,00	0,8																									

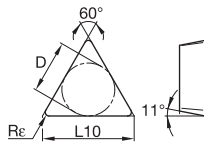

ISO catalogue number	D	L10	Re																									
	mm	mm	mm	KCP05	KCP10	KCP25	KCP30	KCP40	KCK05	KCK15	KCK20	KCM15	KCM25	KCM35	KU10	K313	K68	KCS10	KCU10	KC5010	KC5510	KCU25	KC5025	KC5525	KC5410	KT315	KTP10	
TPUN110304	6,35	11,00	0,4																									
TPUN110308	6,35	11,00	0,8																									
TPUN160304	9,53	16,50	0,4																									
TPUN160308	9,53	16,50	0,8																									
TPUN220408	12,70	22,00	0,8																									
TPUN220412	12,70	22,00	1,2																									



Inserts

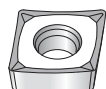

■ CCGT-HP

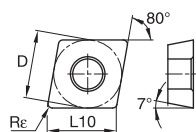

● first choice
○ alternate choice

ISO catalogue number	D mm	L10 mm	Re mm	Material Grades																								
				KCP05	KCP10	KCP25	KCP30	KCP40	KCK05	KCK15	KCK20	KCM15	KCM25	KCM35	KU10	K313	K68	KCS10	KCU10	KCS010	KCU25	KCU5025	KCS525	KCS410	KT315	KTP10		
CCGT060202HP	6,35	6,45	0,2																									
CCGT060204HP	6,35	6,45	0,4																									
CCGT060208HP	6,35	6,45	0,8																									
CCGT09T302HP	9,53	9,67	0,2																									
CCGT09T304HP	9,53	9,67	0,4																									
CCGT09T308HP	9,53	9,67	0,8																									
CCGT09T316HP	9,53	9,67	1,6																									
CCGT120401HP	12,70	12,90	0,1																									
CCGT120402HP	12,70	12,90	0,2																									
CCGT120404HP	12,70	12,90	0,4																									
CCGT120408HP	12,70	12,90	0,8																									



■ CCGT-LF

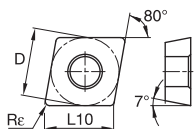

ISO catalogue number	D mm	L10 mm	Re mm	Material Grades																								
				KCP05	KCP10	KCP25	KCP30	KCP40	KCK05	KCK15	KCK20	KCM15	KCM25	KCM35	KU10	K313	K68	KCS10	KCU10	KCS010	KCU25	KCU5025	KCS525	KCS410	KT315	KTP10		
CCGT0602X0LF	6,35	6,45	0,0																									
CCGT060201LF	6,35	6,45	0,1																									
CCGT060202LF	6,35	6,45	0,2																									
CCGT060204LF	6,35	6,45	0,4																									
CCGT060208LF	6,35	6,45	0,8																									
CCGT09T3X0LF	9,53	9,67	0,0																									
CCGT09T301LF	9,53	9,67	0,1																									
CCGT09T302LF	9,53	9,67	0,2																									
CCGT09T304LF	9,53	9,67	0,4																									
CCGT09T308LF	9,53	9,67	0,8																									

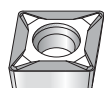

■ CCMT-11

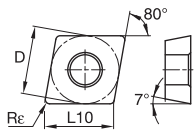

ISO catalogue number	D mm	L10 mm	Re mm	Material Grades																								
				KCP05	KCP10	KCP25	KCP30	KCP40	KCK05	KCK15	KCK20	KCM15	KCM25	KCM35	KU10	K313	K68	KCS10	KCU10	KCS010	KCU25	KCU5025	KCS525	KCS410	KT315	KTP10		
CCMT06020411	6,35	6,45	0,4																									
CCMT09T30411	9,53	9,67	0,4																									
CCMT09T30811	9,53	9,67	0,8																									
CCMT12040411	12,70	12,90	0,4																									
CCMT12040811	12,70	12,90	0,8																									

Inserts



■ **CCMT-MF**

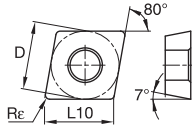

● first choice
○ alternate choice

ISO catalogue number	D mm	L10 mm	Re mm																							
				KCP05	KCP10	KCP25	KCP30	KCP40	KCK05	KCK15	KCK20	KCM15	KCM25	KCM35	KU10	K313	K68	KCS10	KCU10	KC5010	KC5510	KCU25	KC5025	KC5525	KC5410	KT315
CCMT060204MF	6,35	6,45	0,4	●	●	●	●																			
CCMT09T304MF	9,53	9,67	0,4	●	●	●	●																			
CCMT09T308MF	9,53	9,67	0,8	●	●	●																				
CCMT09T312MF	9,53	9,67	1,2	●	●	●																				
CCMT120408MF	12,70	12,90	0,8	●	●	●																				
CCMT120412MF	12,70	12,90	1,2	●	●	●																				



■ **CCMT-MP**

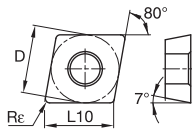

ISO catalogue number	D mm	L10 mm	Re mm																							
				KCP05	KCP10	KCP25	KCP30	KCP40	KCK05	KCK15	KCK20	KCM15	KCM25	KCM35	KU10	K313	K68	KCS10	KCU10	KC5010	KC5510	KCU25	KC5025	KC5525	KC5410	KT315
CCMT060204MP	6,35	6,45	0,4	●	●																					
CCMT09T304MP	9,53	9,67	0,4	●	●																					
CCMT09T308MP	9,53	9,67	0,8	●	●																					
CCMT09T312MP	9,53	9,67	1,2	●	●																					
CCMT120408MP	12,70	12,90	0,8	●	●																					
CCMT120412MP	12,70	12,90	1,2	●	●																					



■ **CCMT-MW**

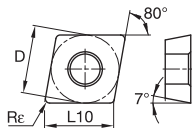

ISO catalogue number	D mm	L10 mm	Re mm																							
				KCP05	KCP10	KCP25	KCP30	KCP40	KCK05	KCK15	KCK20	KCM15	KCM25	KCM35	KU10	K313	K68	KCS10	KCU10	KC5010	KC5510	KCU25	KC5025	KC5525	KC5410	KT315
CCMT09T304MW	9,53	9,67	0,40	●	●																					
CCMT09T308MW	9,53	9,67	0,80	●	●																					
CCMT120404MW	12,70	12,90	0,40	●	●																					
CCMT120408MW	12,70	12,90	0,80	●	●																					



■ **CCMT-UF**

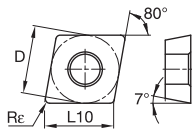

ISO catalogue number	D mm	L10 mm	Re mm																							
				KCP05	KCP10	KCP25	KCP30	KCP40	KCK05	KCK15	KCK20	KCM15	KCM25	KCM35	KU10	K313	K68	KCS10	KCU10	KC5010	KC5510	KCU25	KC5025	KC5525	KC5410	KT315
CCMT060204UF	6,35	6,45	0,4	●	●	●																				
CCMT09T302UF	9,53	9,67	0,2	●	●																					
CCMT09T304UF	9,53	9,67	0,4	●	●	●																				
CCMT09T308UF	9,53	9,67	0,8	●	●	●																				

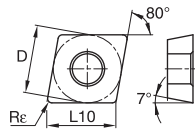

● first choice
 ○ alternate choice

P	●	●	●	●	●																		●	●
M	●								●	●					●	●								●
K	●	●	●	●					●	●	●													●
N																								
S																								
H																								

ISO catalogue number	D mm	L10 mm	Re mm	KCP05	KCP10	KCP25	KCP30	KCP40	KCK05	KCK15	KCK20	KCM15	KCM25	KCM35	KU10	K313	K68	KCS10	KCU10	KCS010	KCS510	KCU25	KCS025	KCS525	KCS410	KT315	KTP10	
CCMW060204	6,35	6,45	0,4								●																	
CCMW09T304	9,53	9,67	0,4								●																	
CCMW09T308	9,53	9,67	0,8								●																	
CCMW120408	12,70	12,90	0,8								●																	
CCMW120412	12,70	12,90	1,2								●																	

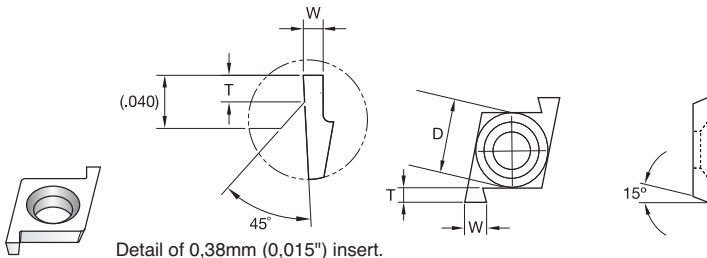

ISO catalogue number	D mm	T mm	W mm	right hand	CDG127050R	CDG127064R	CDG127076R	CDG127102R
right hand								
CDG127050R	3,96	0,64	0,51					
CDG127064R	3,96	1,02	0,64				●	
CDG127076R	3,96	1,02	0,76				●	●
CDG127102R	3,96	1,02	1,02				●	●

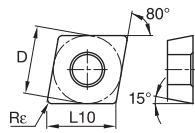

ISO catalogue number	D mm	L10 mm	Re mm	CDHBS4T0S0	CDHBS4T0X0	CDHBS4T002	CDHBS4T004
CDHBS4T0S0	3,97	4,03	0,1			●	●
CDHBS4T0X0	3,97	4,03	0,1				
CDHBS4T002	3,97	4,03	0,2			●	●
CDHBS4T004	3,97	4,03	0,4			●	●



Inserts



CDHH

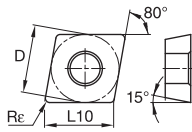

● first choice
○ alternate choice

ISO catalogue number	D mm	L10 mm	Re mm	KCP05	KCP10	KCP25	KCP30	KCP40	KCK05	KCK15	KCK20	KCM15	KCM25	KCM35	KU10	K313	K68	KCS10	KGU10	KCS010	KCS510	KCU25	KCS025	KCS525	KCS410	KT315	KTP10
right hand CDHHS4T002R	3,97	4,03	0,2																	●	●		●	●		●	
CDHHS4T004R left hand	3,97	4,03	0,4																	●	●		●	●		●	
CDHHS4T002L	3,97	4,03	0,2																	●	●		●	●		●	
CDHHS4T004L	3,97	4,03	0,4																	●	●		●	●		●	

NOTE: Right-hand insert uses left-hand bars. Left-hand insert uses right-hand bars.



CDT

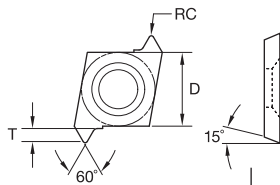

ISO catalogue number	D mm	T mm	RC mm	KCP05	KCP10	KCP25	KCP30	KCP40	KCK05	KCK15	KCK20	KCM15	KCM25	KCM35	KU10	K313	K68	KCS10	KGU10	KCS010	KCS510	KCU25	KCS025	KCS525	KCS410	KT315	KTP10
right hand CDT127005R	3,96	0,64	0,05																	●	●						

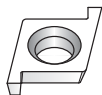

CPG

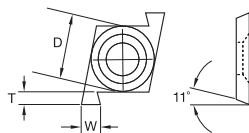

ISO catalogue number	D mm	T mm	W mm	KCP05	KCP10	KCP25	KCP30	KCP40	KCK05	KCK15	KCK20	KCM15	KCM25	KCM35	KU10	K313	K68	KCS10	KGU10	KCS010	KCS510	KCU25	KCS025	KCS525	KCS410	KT315	KTP10
right hand CPG190150R	6,35	1,65	1,52																	●							
left hand CPG190150L	6,35	1,65	1,52																	●							

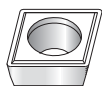

CPGH (T)

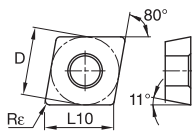

ISO catalogue number	D mm	L10 mm	Re mm	KCP05	KCP10	KCP25	KCP30	KCP40	KCK05	KCK15	KCK20	KCM15	KCM25	KCM35	KU10	K313	K68	KCS10	KGU10	KCS010	KCS510	KCU25	KCS025	KCS525	KCS410	KT315	KTP10
CPGT060202K	6,35	6,45	0,2																	●	●						
CPGT060204K	6,35	6,45	0,4																	●	●					●	
CPGT060208K	6,35	6,45	0,8																	●	●					●	
CPGH09T301	9,53	9,67	0,1																	●	●		●	●		●	
CPGH09T302	9,53	9,67	0,2																	●	●		●	●		●	
CPGH09T304	9,53	9,67	0,4																	●	●		●	●		●	
CPGH09T308	9,53	9,67	0,8																	●	●		●	●		●	



● first choice
○ alternate choice



■ CPGT-HP

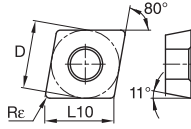

ISO catalogue number	D mm	L10 mm	Re mm	P	M	K	N	S	H	KCP05	KCP10	KCP25	KCP30	KCP40	KCK05	KCK15	KCK20	KCM15	KCM25	KCM35	KU10	K313	K68	KCS10	KCU10	KC5010	KC510	KCU25	KC5025	KC5525	KC5410	KT315	KTP10	
				●	●	●	●	●	●	●	●	●	●	●	●	●	●	●	●	●	●	●	●	●	●	●	●	●	●	●	●	●	●	●
CPGT060202HP	6,35	6,45	0,2																															
CPGT060204HP	6,35	6,45	0,4																															
CPGT060208HP	6,35	6,45	0,8																															
CPGT09T302HP	9,53	9,67	0,2																															
CPGT09T304HP	9,53	9,67	0,4																															
CPGT09T308HP	9,53	9,67	0,8																															



■ CPGT-LF

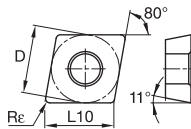

ISO catalogue number	D mm	L10 mm	Re mm	P	M	K	N	S	H	KCP05	KCP10	KCP25	KCP30	KCP40	KCK05	KCK15	KCK20	KCM15	KCM25	KCM35	KU10	K313	K68	KCS10	KCU10	KC5010	KC510	KCU25	KC5025	KC5525	KC5410	KT315	KTP10	
				●	●	●	●	●	●	●	●	●	●	●	●	●	●	●	●	●	●	●	●	●	●	●	●	●	●	●	●	●	●	●
CPGT060201LF	6,35	6,45	0,1																															
CPGT060202LF	6,35	6,45	0,2																															
CPGT060204LF	6,35	6,45	0,4																															
CPGT060208LF	6,35	6,45	0,8																															
CPGT09T302LF	9,53	9,67	0,2																															
CPGT09T304LF	9,53	9,67	0,4																															
CPGT09T308LF	9,53	9,67	0,8																															



■ CPMT-FP

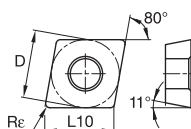

ISO catalogue number	D mm	L10 mm	Re mm	P	M	K	N	S	H	KCP05	KCP10	KCP25	KCP30	KCP40	KCK05	KCK15	KCK20	KCM15	KCM25	KCM35	KU10	K313	K68	KCS10	KCU10	KC5010	KC510	KCU25	KC5025	KC5525	KC5410	KT315	KTP10	
				●	●	●	●	●	●	●	●	●	●	●	●	●	●	●	●	●	●	●	●	●	●	●	●	●	●	●	●	●	●	●
CPMT050202FP	5,56	5,65	0,2																															
CPMT050204FP	5,56	5,65	0,4																															
CPMT060202FP	6,35	6,45	0,2																															
CPMT060204FP	6,35	6,45	0,4																															
CPMT060208FP	6,35	6,45	0,8																															
CPMT09T302FP	9,53	9,67	0,2																															
CPMT09T304FP	9,53	9,67	0,4																															
CPMT09T308FP	9,53	9,67	0,8																															

						
C2-C71	C72-C109	C110-C115	C116-C147	B10-B23	B24-B31	B32-B37

Inserts

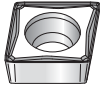

■ CPMT-FW

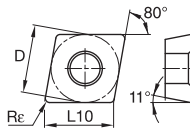

● first choice
○ alternate choice

ISO catalogue number	D mm	L10 mm	Re mm																								
				KCP05	KCP10	KCP25	KCP30	KCP40	KCK05	KCK15	KCK20	KCM15	KCM25	KCM35	KU10	K313	K68	KCS10	KCU10	KCS010	KCS510	KCU25	KCS025	KCS525	KCS410	KT315	KTP10
CPMT060202FW	6,35	6,45	0,2																								
CPMT060204FW	6,35	6,45	0,4			●																					
CPMT060208FW	6,35	6,45	0,8			●																					
CPMT09T304FW	9,53	9,67	0,4			●																					
CPMT09T308FW	9,53	9,67	0,8			●																					

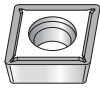

■ CPMT-LF

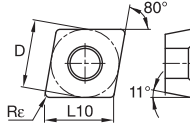

ISO catalogue number	D mm	L10 mm	Re mm																								
				KCP05	KCP10	KCP25	KCP30	KCP40	KCK05	KCK15	KCK20	KCM15	KCM25	KCM35	KU10	K313	K68	KCS10	KCU10	KCS010	KCS510	KCU25	KCS025	KCS525	KCS410	KT315	KTP10
CPMT050202LF	5,56	5,65	0,2																								
CPMT050204LF	5,56	5,65	0,4																								
CPMT060202LF	6,35	6,45	0,2																								
CPMT060204LF	6,35	6,45	0,4	●	●	●	●			●	●	●	●			●	●			●	●		●	●		●	
CPMT060208LF	6,35	6,45	0,8	●	●	●	●			●	●	●	●			●	●			●	●		●	●		●	
CPMT09T302LF	9,53	9,67	0,2																								
CPMT09T304LF	9,53	9,67	0,4	●	●	●	●			●	●	●	●			●	●			●	●		●	●		●	
CPMT09T308LF	9,53	9,67	0,8	●	●	●	●			●	●	●	●			●	●			●	●		●	●		●	



■ CPMT-MF

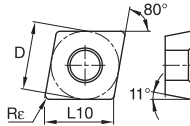

ISO catalogue number	D mm	L10 mm	Re mm																								
				KCP05	KCP10	KCP25	KCP30	KCP40	KCK05	KCK15	KCK20	KCM15	KCM25	KCM35	KU10	K313	K68	KCS10	KCU10	KCS010	KCS510	KCU25	KCS025	KCS525	KCS410	KT315	KTP10
CPMT060208MF	6,35	6,45	0,8			●	●																				
CPMT09T308MF	9,53	9,67	0,8			●	●	●																			
CPMT09T312MF	9,53	9,67	1,2			●	●																				

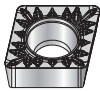

■ CPMT-MP

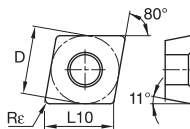

ISO catalogue number	D mm	L10 mm	Re mm																								
				KCP05	KCP10	KCP25	KCP30	KCP40	KCK05	KCK15	KCK20	KCM15	KCM25	KCM35	KU10	K313	K68	KCS10	KCU10	KCS010	KCS510	KCU25	KCS025	KCS525	KCS410	KT315	KTP10
CPMT060208MP	6,35	6,45	0,8			●	●																				
CPMT09T308MP	9,53	9,67	0,8			●	●																				
CPMT09T312MP	9,53	9,67	1,2																								

● first choice
○ alternate choice

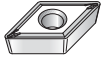

■ DCGT-LF

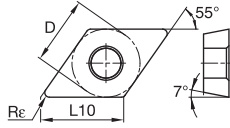

	D	L10	Re	KCP05	KCP10	KCP25	KCP30	KCP40	KCK05	KCK15	KCK20	KCM15	KCM25	KCM35	KU10	K313	K68	KCS10	KCU10	KCS010	KCS510	KCU25	KC5025	KCS525	KCS410	KT315	KTP10
ISO catalogue number	mm	mm	mm																								
DCGT0702X0LF	6,35	7,75	0,0																								
DCGT070201LF	6,35	7,75	0,1																	●	●			●			
DCGT11T3X0LF	9,53	11,63	0,0																								
DCGT11T301LF	9,53	11,63	0,1																	●	●			●			
DCGT150408LF	12,70	15,50	0,8																	●	●			●			

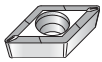

■ DCMT-11

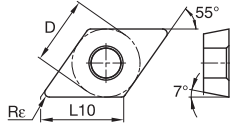

	D	L10	Re	KCP05	KCP10	KCP25	KCP30	KCP40	KCK05	KCK15	KCK20	KCM15	KCM25	KCM35	KU10	K313	K68	KCS10	KCU10	KCS010	KCS510	KCU25	KC5025	KCS525	KCS410	KT315	KTP10
ISO catalogue number	mm	mm	mm																								
DCMT07020211	6,35	7,75	0,2																								●
DCMT07020411	6,35	7,75	0,4																								●
DCMT11T30411	9,53	11,63	0,4																								●
DCMT11T30811	9,53	11,63	0,8																								●

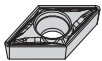

■ DCMT-FP

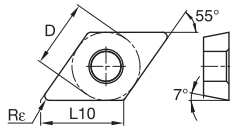

	D	L10	Re	KCP05	KCP10	KCP25	KCP30	KCP40	KCK05	KCK15	KCK20	KCM15	KCM25	KCM35	KU10	K313	K68	KCS10	KCU10	KCS010	KCS510	KCU25	KC5025	KCS525	KCS410	KT315	KTP10
ISO catalogue number	mm	mm	mm																								
DCMT070202FP	6,35	7,75	0,2	●	●						●	●			●				●			●					●
DCMT070204FP	6,35	7,75	0,4	●	●						●	●			●				●			●					●
DCMT070208FP	6,35	7,75	0,8	●	●						●	●			●				●			●					●
DCMT11T302FP	9,53	11,63	0,2			●	●					●								●			●				●
DCMT11T304FP	9,53	11,63	0,4	●	●	●					●	●	●		●				●			●					●
DCMT11T308FP	9,53	11,63	0,8	●	●	●					●	●	●		●				●			●					●
DCMT11T312FP	9,53	11,63	1,2			●	●					●							●								●
DCMT150404FP	12,70	15,50	0,4			●	●					●							●								●
DCMT150408FP	12,70	15,50	0,8	●	●	●					●	●							●								●



■ DCMT-FW

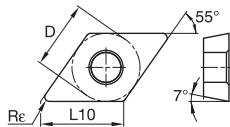

	D	L10	Re	KCP05	KCP10	KCP25	KCP30	KCP40	KCK05	KCK15	KCK20	KCM15	KCM25	KCM35	KU10	K313	K68	KCS10	KCU10	KCS010	KCS510	KCU25	KC5025	KCS525	KCS410	KT315	KTP10
ISO catalogue number	mm	mm	mm																								
DCMT11T304FW	9,53	11,63	0,2			●					●								●	●							●
DCMT11T308FW	9,53	11,63	0,8			●					●								●	●							●

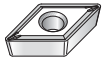

■ DCMT-LF

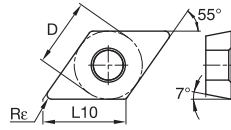

● first choice
○ alternate choice

ISO catalogue number	D mm	L10 mm	Re mm	Material																						
				KCP05	KCP10	KCP25	KCP30	KCP40	KCK05	KCK15	KCK20	KCM15	KCM25	KCM35	KU10	K313	K68	KCS10	KCU10	KCS010	KCS510	KCU25	KC5025	KC5525	KCS410	KT315
DCMT070202LF	6,35	7,75	0,2																							
DCMT070204LF	6,35	7,75	0,4	●	●	●	●	●	●	●	●	●	●	●	●	●	●	●	●	●	●	●	●	●	●	●
DCMT11T302LF	9,53	11,63	0,2																							
DCMT11T304LF	9,53	11,63	0,4	●	●	●	●	●	●	●	●	●	●	●	●	●	●	●	●	●	●	●	●	●	●	●
DCMT11T308LF	9,53	11,63	0,8	●	●	●	●	●	●	●	●	●	●	●	●	●	●	●	●	●	●	●	●	●	●	●
DCMT11T312LF	9,53	11,63	1,2	●	●	●	●	●	●	●	●	●	●	●	●	●	●	●	●	●	●	●	●	●	●	●
DCMT150404LF	12,70	15,50	0,4	●	●																					
DCMT150408LF	12,70	15,50	0,8	●	●			●																		●



■ DCMT-MF

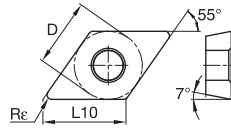

ISO catalogue number	D mm	L10 mm	Re mm	Material																						
				KCP05	KCP10	KCP25	KCP30	KCP40	KCK05	KCK15	KCK20	KCM15	KCM25	KCM35	KU10	K313	K68	KCS10	KCU10	KCS010	KCS510	KCU25	KC5025	KC5525	KCS410	KT315
DCMT11T304MF	9,53	11,63	0,4	●	●	●				●	●	●	●													
DCMT11T308MF	9,53	11,63	0,8	●	●	●				●	●	●	●	●												
DCMT11T312MF	9,53	11,63	1,2	●	●					●	●	●	●													

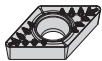

■ DCMT-MP

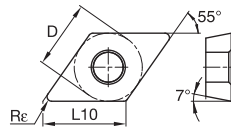

ISO catalogue number	D mm	L10 mm	Re mm	Material																						
				KCP05	KCP10	KCP25	KCP30	KCP40	KCK05	KCK15	KCK20	KCM15	KCM25	KCM35	KU10	K313	K68	KCS10	KCU10	KCS010	KCS510	KCU25	KC5025	KC5525	KCS410	KT315
DCMT11T304MP	9,53	11,63	0,4	●	●					●	●															
DCMT11T308MP	9,53	11,63	0,8	●	●					●	●	●														
DCMT11T312MP	9,53	11,63	1,2	●	●														●							



■ DCMT-MW

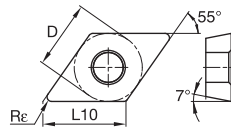

ISO catalogue number	D mm	L10 mm	Re mm	Material																						
				KCP05	KCP10	KCP25	KCP30	KCP40	KCK05	KCK15	KCK20	KCM15	KCM25	KCM35	KU10	K313	K68	KCS10	KCU10	KCS010	KCS510	KCU25	KC5025	KC5525	KCS410	KT315
DCMT11T304MW	9,53	11,63	0,4										●													
DCMT11T308MW	9,53	11,63	0,8										●													



Inserts



■ DCMT-UF

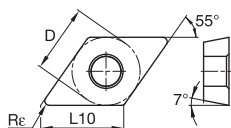

● first choice
○ alternate choice

ISO catalogue number	D	L10	Re																									
	mm	mm	mm	KCP05	KCP10	KCP25	KCP30	KCP40	KCK05	KCK15	KCK20	KCM15	KCM25	KCM35	KU10	K313	K68	KCS10	KCU10	KC5010	KC5510	KCU25	KC5025	KC5525	KC5410	KT315	KTP10	
DCMT070204UF	6,35	7,75	0,4	●	●	●														●								
DCMT11T302UF	9,53	11,63	0,2	●	●	●														●								
DCMT11T304UF	9,53	11,63	0,4	●	●	●														●								
DCMT11T308UF	9,53	11,63	0,8	●	●	●														●								



■ DPGT-HP

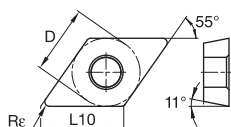

ISO catalogue number	D	L10	Re																									
	mm	mm	mm	KCP05	KCP10	KCP25	KCP30	KCP40	KCK05	KCK15	KCK20	KCM15	KCM25	KCM35	KU10	K313	K68	KCS10	KCU10	KC5010	KC5510	KCU25	KC5025	KC5525	KC5410	KT315	KTP10	
DPGT070202HP	6,35	7,75	0,2													●			●	●		●	●			●	●	
DPGT070204HP	6,35	7,75	0,4													●			●	●		●	●			●	●	
DPGT070208HP	6,35	7,75	0,8													●			●	●		●	●			●	●	
DPGT11T304HP	9,53	11,63	0,4													●			●	●		●	●			●	●	
DPGT11T308HP	9,53	11,63	0,8													●			●	●		●	●			●	●	

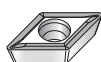

■ DPGT-LF

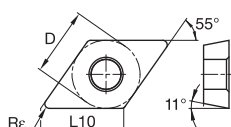

ISO catalogue number	D	L10	Re																									
	mm	mm	mm	KCP05	KCP10	KCP25	KCP30	KCP40	KCK05	KCK15	KCK20	KCM15	KCM25	KCM35	KU10	K313	K68	KCS10	KCU10	KC5010	KC5510	KCU25	KC5025	KC5525	KC5410	KT315	KTP10	
DPGT070201LF	6,35	7,75	0,1																●	●		●	●			●	●	
DPGT070202LF	6,35	7,75	0,2																●	●		●	●			●	●	
DPGT070204LF	6,35	7,75	0,4																●	●		●	●			●	●	
DPGT11T301LF	9,53	11,63	0,1																●	●		●	●			●	●	
DPGT11T302LF	9,53	11,63	0,2																●	●		●	●			●	●	
DPGT11T304LF	9,53	11,63	0,4																●	●		●	●			●	●	
DPGT11T308LF	9,53	11,63	0,8																●	●		●	●			●	●	

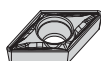

■ DPMT-FP

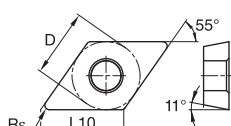

ISO catalogue number	D	L10	Re																									
	mm	mm	mm	KCP05	KCP10	KCP25	KCP30	KCP40	KCK05	KCK15	KCK20	KCM15	KCM25	KCM35	KU10	K313	K68	KCS10	KCU10	KC5010	KC5510	KCU25	KC5025	KC5525	KC5410	KT315	KTP10	
DPMT070202FP	6,35	7,75	0,2																●	●		●	●			●	●	
DPMT070204FP	6,35	7,75	0,4		●	●						●	●						●	●		●	●			●	●	
DPMT070208FP	6,35	7,75	0,8																●	●		●	●			●	●	
DPMT11T302FP	9,53	11,63	0,2																●	●		●	●			●	●	
DPMT11T304FP	9,53	11,63	0,4		●	●					●	●							●	●		●	●			●	●	
DPMT11T308FP	9,53	11,63	0,8		●	●					●	●							●	●		●	●			●	●	



DPMT-FW

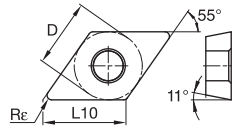

● first choice
○ alternate choice

ISO catalogue number	D mm	L10 mm	Re mm	Material																						
				KCP05	KCP10	KCP25	KCP30	KCP40	KCK05	KCK15	KCK20	KCM15	KCM25	KCM35	KU10	K313	K68	KCS10	KCU10	KC5010	KC5510	KCU25	KC5025	KC5525	KC5410	KT315
DPMT070204FW	6,35	7,75	0,4																							
DPMT070208FW	6,35	7,75	0,8			●						●						●	●							
DPMT11T304FW	9,53	11,63	0,2			●																				
DPMT11T308FW	9,53	11,63	0,8									●														

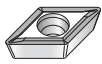

DPMT-LF

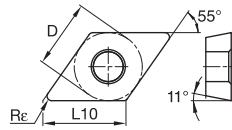

ISO catalogue number	D mm	L10 mm	Re mm	Material																						
				KCP05	KCP10	KCP25	KCP30	KCP40	KCK05	KCK15	KCK20	KCM15	KCM25	KCM35	KU10	K313	K68	KCS10	KCU10	KC5010	KC5510	KCU25	KC5025	KC5525	KC5410	KT315
DPMT070202LF	6,35	7,75	0,2																							
DPMT070204LF	6,35	7,75	0,4			●	●	●		●		●	●	●					●				●			●
DPMT11T302LF	9,53	11,63	0,2																							
DPMT11T304LF	9,53	11,63	0,4	●	●	●	●		●		●	●	●					●				●			●	●
DPMT11T308LF	9,53	11,63	0,8	●	●	●	●		●		●	●	●					●				●			●	●

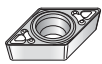

DPMT-MF

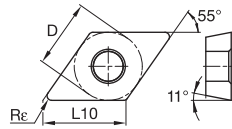

ISO catalogue number	D mm	L10 mm	Re mm	Material																						
				KCP05	KCP10	KCP25	KCP30	KCP40	KCK05	KCK15	KCK20	KCM15	KCM25	KCM35	KU10	K313	K68	KCS10	KCU10	KC5010	KC5510	KCU25	KC5025	KC5525	KC5410	KT315
DPMT11T308MF	9,53	11,63	0,8			●	●					●	●	●	●											



DPMT-MP

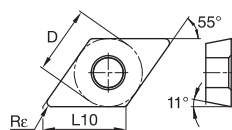

ISO catalogue number	D mm	L10 mm	Re mm	Material																						
				KCP05	KCP10	KCP25	KCP30	KCP40	KCK05	KCK15	KCK20	KCM15	KCM25	KCM35	KU10	K313	K68	KCS10	KCU10	KC5010	KC5510	KCU25	KC5025	KC5525	KC5410	KT315
DPMT11T308MP	9,53	11,63	0,8			●						●							●							



Inserts



■ DPMT-UF

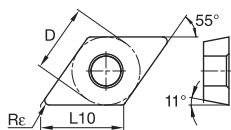

● first choice
○ alternate choice

ISO catalogue number	D	L10	Re
	mm	mm	mm
DPMT070204UF	6,35	7,75	0,4
DPMT11T304UF	9,53	11,63	0,4
DPMT11T308UF	9,53	11,63	0,8

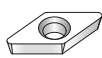

■ GPCD

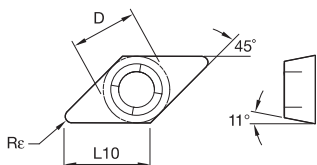

ISO catalogue number	D	L10	Re
	mm	mm	mm
GPCD050102	3,97	5,61	0,2
GPCD050104	3,97	5,61	0,4

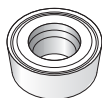

■ RCGH

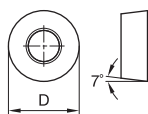

ISO catalogue number	D	L10	Re
	mm	mm	mm
RCGH120400	12,70	—	—

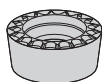

■ RCGH-MP

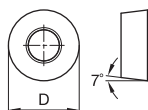

ISO catalogue number	D	L10	Re
	mm	mm	mm
RCGH09T300MP	9,53	—	—
RCGH120400MP	12,70	—	—

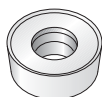

■ RCGT-HP

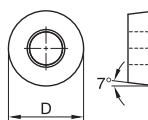

ISO catalogue number	D	L10	Re
	mm	mm	mm
RCGT0803M0HP	8,00	—	—
RCGT10T3M0HP	10,00	—	—
RCGT1204M0HP	12,00	—	—

P	M	K	N	S	H	KCP05	KCP10	KCP25	KCP30	KCP40	KCK05	KCK15	KCK20	KCM15	KCM25	KCM35	KU10	K313	K68	KCS10	KCU10	KCS010	KCS510	KCU25	KCS025	KCS525	KCS410	KT315	KTP10
●	●	●	●	●	●																								
●	●	●	●	●	●																								
●	●	●	●	●	●																								
●	●	●	●	●	●																								

● first choice
○ alternate choice



■ RCGT-MS

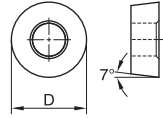

ISO catalogue number	D	L10	Re																									
	mm	mm	mm	KCP05	KCP10	KCP25	KCP30	KCP40	KCK05	KCK15	KCK20	KCM15	KCM25	KCM35	KU10	K313	K68	KCS10	KCU10	KC5010	KC5510	KCU25	KC5025	KC5525	KC9410	KT315	KTP10	
RCGT0803M0MS	8,00	—	—																									
RCGT1204M0MS	12,00	—	—																									
RCGT1606M0MS	16,00	—	—																									
RCGX1003M0MS	10,00	—	—																									



■ RCGT-RP

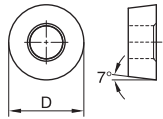

ISO catalogue number	D	L10	Re																									
	mm	mm	mm	KCP05	KCP10	KCP25	KCP30	KCP40	KCK05	KCK15	KCK20	KCM15	KCM25	KCM35	KU10	K313	K68	KCS10	KCU10	KC5010	KC5510	KCU25	KC5025	KC5525	KC9410	KT315	KTP10	
RCGT0803M0RP	8,00	—	—			●	●																					
RCGT1204M0RP	12,00	—	—			●	●																					
RCGX1003M0RP	10,00	—	—			●	●																					
RCMT1204M0RP	12,00	—	—	●	●					●	●																	
RCMT1606M0RP	16,00	—	—	●	●					●	●																	
RCMT2006M0RP	20,00	—	—	●	●					●	●		●															
RCMX1003M0RP	10,00	—	—	●	●	●																						
RCMX2507M0RP	25,00	—	—	●	●	●																						
RCMX3209M0RP	32,00	—	—	●																								

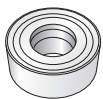

■ RCMT

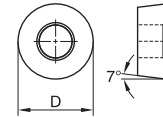

ISO catalogue number	D	L10	Re																									
	mm	mm	mm	KCP05	KCP10	KCP25	KCP30	KCP40	KCK05	KCK15	KCK20	KCM15	KCM25	KCM35	KU10	K313	K68	KCS10	KCU10	KC5010	KC5510	KCU25	KC5025	KC5525	KC9410	KT315	KTP10	
RCMT0602M0	6,00	—	—			●	●					●	●					●	●									
RCMT0803M0	8,00	—	—			●	●					●	●					●	●									
RCMT10T3M0	10,00	—	—			●	●					●	●					●	●									
RCMT1204M0	12,00	—	—			●	●					●	●					●	●									
RCMT1605M0	16,00	—	—			●	●					●	●					●	●									
RCMT2006M0	20,00	—	—			●	●					●	●					●	●									
RCMT060200	6,35	—	—			●	●					●	●					●	●									
RCMT09T300	9,53	—	—			●	●					●	●					●	●								●	
RCMT120400	12,70	—	—			●	●					●	●					●	●									



Inserts

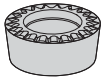

■ RCMT-MP

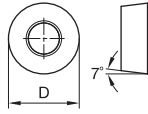

● first choice
○ alternate choice

ISO catalogue number	D	L10	Re																									
	mm	mm	mm	KCP05	KCP10	KCP25	KCP30	KCP40	KCK05	KCK15	KCK20	KCM15	KCM25	KCM35	KU10	K313	K68	KCS10	KCU10	KC5010	KC5510	KCU25	KC5025	KC5525	KC5410	KT315	KTP10	
RCMT0602M0MP	6,00	—	—																									
RCMT0803M0MP	8,00	—	—																									
RCMT10T3M0MP	10,00	—	—																									
RCMT1204M0MP	12,00	—	—																									
RCMT1606M0MP	16,00	—	—																									
RCMT060200MP	6,35	—	—																									
RCMT120400MP	12,70	—	—																									

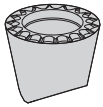

■ RPGT-MP

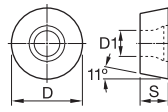

ISO catalogue number	D	L10	Re																									
	mm	mm	mm	KCP05	KCP10	KCP25	KCP30	KCP40	KCK05	KCK15	KCK20	KCM15	KCM25	KCM35	KU10	K313	K68	KCS10	KCU10	KC5010	KC5510	KCU25	KC5025	KC5525	KC5410	KT315	KTP10	
RPGT060400MP	6,35	—	—																									
RPGT090700MP	9,53	—	—																									
RPGT120700MP	12,70	—	—																									



■ RCMT-RH

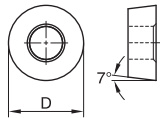

ISO catalogue number	D	L10	Re																									
	mm	mm	mm	KCP05	KCP10	KCP25	KCP30	KCP40	KCK05	KCK15	KCK20	KCM15	KCM25	KCM35	KU10	K313	K68	KCS10	KCU10	KC5010	KC5510	KCU25	KC5025	KC5525	KC5410	KT315	KTP10	
RCMT2006M0RH	20,00	—	—																									
RCMX2507M0RH	25,00	—	—																									
RCMX3209M0RH	32,00	—	—																									



■ RCMT-RM

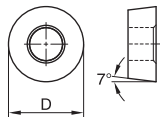

ISO catalogue number	D	L10	Re																									
	mm	mm	mm	KCP05	KCP10	KCP25	KCP30	KCP40	KCK05	KCK15	KCK20	KCM15	KCM25	KCM35	KU10	K313	K68	KCS10	KCU10	KC5010	KC5510	KCU25	KC5025	KC5525	KC5410	KT315	KTP10	
RCMT2006M0RM	20,00	—	—																									



■ RCMT-RP

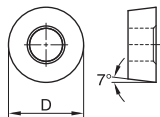

ISO catalogue number	D	L10	Re																									
	mm	mm	mm	KCP05	KCP10	KCP25	KCP30	KCP40	KCK05	KCK15	KCK20	KCM15	KCM25	KCM35	KU10	K313	K68	KCS10	KCU10	KC5010	KC5510	KCU25	KC5025	KC5525	KC5410	KT315	KTP10	
RCGT0803M0RP	8,00	—	—																									
RCMT1204M0RP	12,00	—	—																									
RCMT1606M0RP	16,00	—	—																									
RCMT2006M0RP	20,00	—	—																									
RCMX1003M0RP	10,00	—	—																									
RCMX2507M0RP	25,00	—	—																									
RCMX3209M0RP	32,00	—	—																									

Inserts

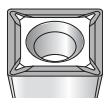

■ SCMT-11

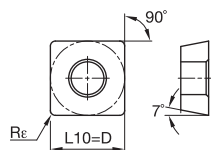

● first choice
○ alternate choice

P	M	K	N	S	H	KCP05	KCP10	KCP25	KCP30	KCP40	KCK05	KCK15	KCK20	KCM15	KCM25	KCM35	KU10	K313	K68	KCS10	KCU10	KCS010	KCS510	KCU25	KCS025	KCS525	KCS410	KT315	KTP10				
●	●	●	●	●	●																												
											●	●	●									●	●		●	●	●					●	

ISO catalogue number	D mm	L10 mm	Re mm
SCMT09T30411	9,53	9,53	0,4
SCMT09T30811	9,53	9,53	0,8
SCMT12040411	12,70	12,70	0,4
SCMT12040811	12,70	12,70	0,8

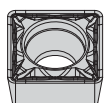

■ SCMT-FP

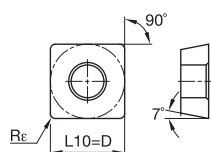

ISO catalogue number	D mm	L10 mm	Re mm
SCMT09T304FP	9,53	9,53	0,4
SCMT09T308FP	9,53	9,53	0,8
SCMT120404FP	12,70	12,70	0,4
SCMT120408FP	12,70	12,70	0,8
SCMT120412FP	12,70	12,70	1,2



■ SCMT-LF

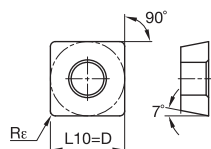

ISO catalogue number	D mm	L10 mm	Re mm
SCMT09T304LF	9,53	9,53	0,4
SCMT09T308LF	9,53	9,53	0,8
SCMT120404LF	12,70	12,70	0,4
SCMT120408LF	12,70	12,70	0,8
SCMT120412LF	12,70	12,70	1,2



■ SCMT-MF

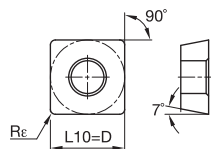

ISO catalogue number	D mm	L10 mm	Re mm
SCMT09T308MF	9,53	9,53	0,8
SCMT120408MF	12,70	12,70	0,8
SCMT120412MF	12,70	12,70	1,2



Inserts

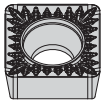

■ SCMT-MP

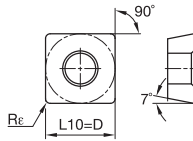

● first choice
○ alternate choice

	D	L10	Re
ISO catalogue number	mm	mm	mm
SCMT09T304MP	9,53	9,53	0,4
SCMT09T308MP	9,53	9,53	0,8
SCMT120404MP	12,70	12,70	0,4
SCMT120408MP	12,70	12,70	0,8
SCMT120412MP	12,70	12,70	1,2

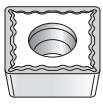

■ SCMT-UF

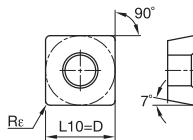

	D	L10	Re
ISO catalogue number	mm	mm	mm
SCMT09T308UF	9,53	9,53	0,8

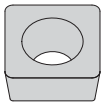

■ SCMW

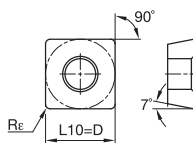

	D	L10	Re
ISO catalogue number	mm	mm	mm
SCMW09T304	9,53	9,53	0,4
SCMW09T308	9,53	9,53	0,8
SCMW120408	12,70	12,70	0,8
SCMW120412	12,70	12,70	1,2

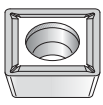

■ SPGH

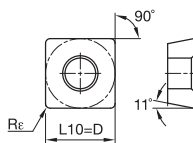

	D	L10	Re
ISO catalogue number	mm	mm	mm
SPGH070208	7,94	7,00	0,8
SPGH090308	9,53	9,53	0,8

	P	M	K	N	S	H	KCP05	KCP10	KCP25	KCP30	KCP40	KCK05	KCK15	KCK20	KCM15	KCM25	KCM35	KU10	K313	K68	KCS10	KCU10	KCS010	KCS510	KCU25	KCS025	KCS525	KCS410	KT315	KTP10
SCMT-MP	●	●	●	●	●	●																								
SCMT-UF							●	●															●							
SCMW														●	●	●														
SPGH																												●	●	

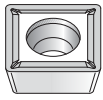

■ SPGT-LF

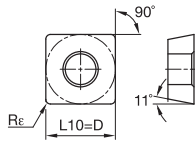

● first choice
○ alternate choice

	D	L10	Re	KCP05	KCP10	KCP25	KCP30	KCP40	KCK05	KCK15	KCK20	KCM15	KCM25	KCM35	KU10	K313	K68	KCS10	KCU10	KC5010	KC5510	KCU25	KC5025	KC5525	KC5410	KT315	KTP10
ISO catalogue number	mm	mm	mm																								
SPGT09T304LF	9,53	9,53	0,4																								
SPGT09T308LF	9,53	9,53	0,8																	●	●			●	●		

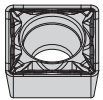

■ SPMT-FP

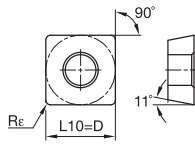

	D	L10	Re	KCP05	KCP10	KCP25	KCP30	KCP40	KCK05	KCK15	KCK20	KCM15	KCM25	KCM35	KU10	K313	K68	KCS10	KCU10	KC5010	KC5510	KCU25	KC5025	KC5525	KC5410	KT315	KTP10
ISO catalogue number	mm	mm	mm																								
SPMT09T304FP	9,53	9,53	0,4	●	●	●					●		●						●			●					
SPMT09T308FP	9,53	9,53	0,8	●	●	●					●				●				●			●					●

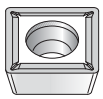

■ SPMT-LF

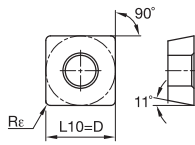

	D	L10	Re	KCP05	KCP10	KCP25	KCP30	KCP40	KCK05	KCK15	KCK20	KCM15	KCM25	KCM35	KU10	K313	K68	KCS10	KCU10	KC5010	KC5510	KCU25	KC5025	KC5525	KC5410	KT315	KTP10
ISO catalogue number	mm	mm	mm																								
SPMT09T304LF	9,53	9,53	0,4	●	●						●									●			●			●	●
SPMT09T308LF	9,53	9,53	0,8	●	●				●	●	●						●			●			●			●	●

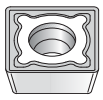

■ SPMT-MF

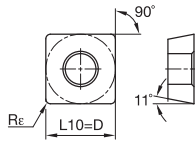

	D	L10	Re	KCP05	KCP10	KCP25	KCP30	KCP40	KCK05	KCK15	KCK20	KCM15	KCM25	KCM35	KU10	K313	K68	KCS10	KCU10	KC5010	KC5510	KCU25	KC5025	KC5525	KC5410	KT315	KTP10
ISO catalogue number	mm	mm	mm																								
SPMT09T308MF	9,53	9,53	0,8	●	●						●	●	●														
SPMT120408MF	12,70	12,70	0,8	●	●	●					●	●	●														



Inserts

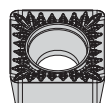

■ SPMT-MP

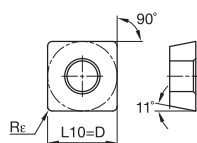

● first choice
○ alternate choice

	D	L10	Re
ISO catalogue number	mm	mm	mm
SPMT09T308MP	9,53	9,53	0,8
SPMT120408MP	12,70	12,70	0,8



■ SPMT-UF

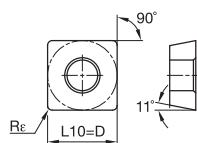

	D	L10	Re
ISO catalogue number	mm	mm	mm
SPMT09T304UF	9,53	9,53	0,4

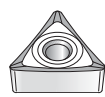

■ TCGT-HP

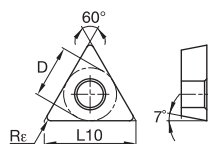

	D	L10	Re
ISO catalogue number	mm	mm	mm
TCGT110202HP	6,35	11,00	0,2
TCGT110204HP	6,35	11,00	0,4
TCGT110208HP	6,35	11,00	0,8
TCGT16T302HP	9,53	16,50	0,2
TCGT16T304HP	9,53	16,50	0,4
TCGT16T308HP	9,53	16,50	0,8

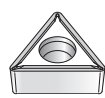

■ TCGT-LF

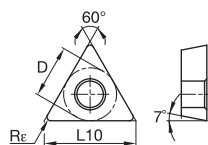

	D	L10	Re
ISO catalogue number	mm	mm	mm
TCGT1102X0LF	6,35	11,00	0,0
TCGT110201LF	6,35	11,00	0,1
TCGT110204LF	6,35	11,00	0,4
TCGT16T301LF	9,53	16,50	0,1
TCGT16T302LF	9,53	16,50	0,2
TCGT16T304LF	9,53	16,50	0,4
TCGT16T308LF	9,53	16,50	0,8

	P	M	K	N	S	H	KCP05	KCP10	KCP25	KCP30	KCP40	KCK05	KCK15	KCK20	KCM15	KCM25	KCM35	KU10	K313	K68	KCS10	KCU10	KCS010	KCS510	KCU25	KCS025	KCS525	KCS410	KT315	KTP10	
SPMT-MP	●	●	●	●	●	●																									
SPMT-UF									●																						
TCGT-HP																															
TCGT-LF																															

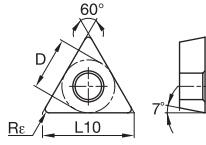

● first choice
○ alternate choice

P	●	●	●	●	●															
M																				
K										●	●	●								
N																				
S																			●	
H																				

ISO catalogue number	D	L10	Re
	mm	mm	mm
TCMT11020411	6,35	11,00	0,4
TCMT16T30411	9,53	16,50	0,4
TCMT16T30811	9,53	16,50	0,8

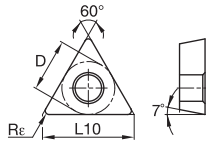

ISO catalogue number	D	L10	Re
	mm	mm	mm
TCMT090204FP	5,56	9,63	0,4
TCMT090208FP	5,56	9,63	0,8
TCMT110202FP	6,35	11,00	0,2
TCMT110204FP	6,35	11,00	0,4
TCMT110208FP	6,35	11,00	0,8
TCMT110304FP	6,35	11,00	0,4
TCMT110308FP	6,35	11,00	0,8
TCMT110312FP	6,35	11,00	1,2
TCMT16T302FP	9,53	16,50	0,2
TCMT16T304FP	9,53	16,50	0,4
TCMT16T308FP	9,53	16,50	0,8
TCMT16T312FP	9,53	16,50	1,2
TCMT220408FP	12,70	22,00	0,8

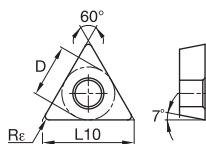

ISO catalogue number	D	L10	Re
	mm	mm	mm
TCMT110202LF	6,35	11,00	0,2
TCMT110204LF	6,35	11,00	0,4
TCMT110208LF	6,35	11,00	0,8
TCMT16T302LF	9,53	16,50	0,2
TCMT16T304LF	9,53	16,50	0,4
TCMT16T308LF	9,53	16,50	0,8
TCMT16T312LF	9,53	16,50	1,2
TCMT220408LF	12,70	22,00	0,8

	KCP05	KCP10	KCP25	KCP30	KCP40	KCK05	KCK15	KCK20	KCM15	KCM25	KCM35	KU10	K313	K68	KCS10	KCU10	KCS010	KCS510	KCU25	KCS025	KCS525	KCS410	KT315	KTP10	



Inserts

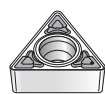

TCMT-MF

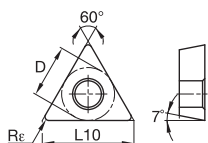

● first choice
○ alternate choice

ISO catalogue number	D mm	L10 mm	Re mm	Material Groups																								
				KCP05	KCP10	KCP25	KCP30	KCP40	KCK05	KCK15	KCK20	KCM15	KCM25	KCM35	KU10	K313	K68	KCS10	KCU10	KC5010	KC5510	KCU25	KC5025	KC5525	KC5410	KT315	KTP10	
TCMT110208MF	6,35	11,00	0,8	●	●																							
TCMT16T308MF	9,53	16,50	0,8	●	●	●																						
TCMT16T312MF	9,53	16,50	1,2	●	●							●	●															



TCMT-MP

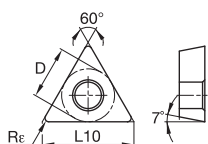

ISO catalogue number	D mm	L10 mm	Re mm	Material Groups																								
				KCP05	KCP10	KCP25	KCP30	KCP40	KCK05	KCK15	KCK20	KCM15	KCM25	KCM35	KU10	K313	K68	KCS10	KCU10	KC5010	KC5510	KCU25	KC5025	KC5525	KC5410	KT315	KTP10	
TCMT110208MP	6,35	11,00	0,8			●						●	●															
TCMT16T304MP	9,53	16,50	0,4			●						●	●															
TCMT16T308MP	9,53	16,50	0,8	●								●	●															
TCMT16T312MP	9,53	16,50	1,2			●						●	●															

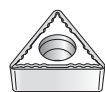

TCMT-UF

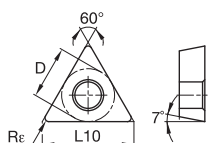

ISO catalogue number	D mm	L10 mm	Re mm	Material Groups																								
				KCP05	KCP10	KCP25	KCP30	KCP40	KCK05	KCK15	KCK20	KCM15	KCM25	KCM35	KU10	K313	K68	KCS10	KCU10	KC5010	KC5510	KCU25	KC5025	KC5525	KC5410	KT315	KTP10	
TCMT110204UF	6,35	11,00	0,4	●	●																							
TCMT110208UF	6,35	11,00	0,8	●	●																							
TCMT16T308UF	9,53	16,50	0,8	●	●																							

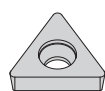

TCMW

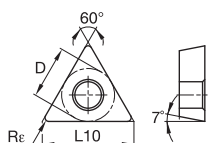

ISO catalogue number	D mm	L10 mm	Re mm	Material Groups																								
				KCP05	KCP10	KCP25	KCP30	KCP40	KCK05	KCK15	KCK20	KCM15	KCM25	KCM35	KU10	K313	K68	KCS10	KCU10	KC5010	KC5510	KCU25	KC5025	KC5525	KC5410	KT315	KTP10	
TCMW16T304	9,53	16,50	0,4									●																
TCMW16T308	9,53	16,50	0,8									●																

Inserts

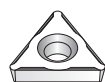

TPCH

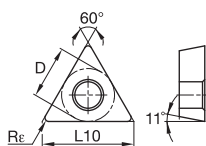

● first choice
○ alternate choice

ISO catalogue number	D mm	L10 mm	Re mm	Material Grades																						
				KCP05	KCP10	KCP25	KCP30	KCP40	KCK05	KCK15	KCK20	KCM15	KCM25	KCM35	KU10	K313	K68	KCS10	KCU10	KC5010	KC5510	KCU25	KC5025	KC5525	KC5410	KT315
TPCH110202	6,50	11,26	0,2																							
TPCH110204	6,50	11,26	0,4																●		●					



TPGH

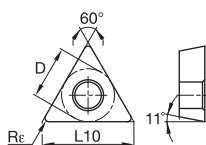

ISO catalogue number	D mm	L10 mm	Re mm	Material Grades																						
				KCP05	KCP10	KCP25	KCP30	KCP40	KCK05	KCK15	KCK20	KCM15	KCM25	KCM35	KU10	K313	K68	KCS10	KCU10	KC5010	KC5510	KCU25	KC5025	KC5525	KC5410	KT315
TPGH160304	9,53	16,50	0,4															●	●							
TPGH160308	9,53	16,50	0,8															●	●		●	●				



TPGM

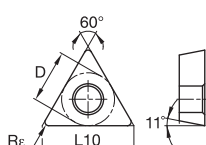

ISO catalogue number	D mm	L10 mm	Re mm	Material Grades																						
				KCP05	KCP10	KCP25	KCP30	KCP40	KCK05	KCK15	KCK20	KCM15	KCM25	KCM35	KU10	K313	K68	KCS10	KCU10	KC5010	KC5510	KCU25	KC5025	KC5525	KC5410	KT315
TPGT110204K	6,35	11,00	0,4															●	●							
TPGT110208K	6,35	11,00	0,8															●	●							
TPGH16T304	9,53	16,50	0,4																●	●						

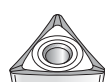

TPGT-HP

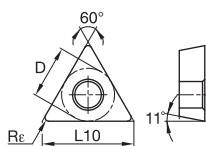

ISO catalogue number	D mm	L10 mm	Re mm	Material Grades																						
				KCP05	KCP10	KCP25	KCP30	KCP40	KCK05	KCK15	KCK20	KCM15	KCM25	KCM35	KU10	K313	K68	KCS10	KCU10	KC5010	KC5510	KCU25	KC5025	KC5525	KC5410	KT315
TPGT110202HP	6,35	11,00	0,2															●		●	●					
TPGT110204HP	6,35	11,00	0,4															●		●	●					
TPGT110208HP	6,35	11,00	0,8																●	●		●	●			
TPGT16T302HP	9,53	16,50	0,2																●	●		●	●			
TPGT16T304HP	9,53	16,50	0,4															●		●	●					
TPGT16T308HP	9,53	16,50	0,8																●	●		●	●			

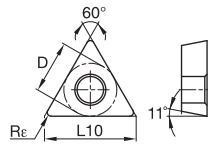

● first choice
○ alternate choice

Material	P	M	K	N	S	H
TPGT-LF	●	●	●	●	●	●
TPHB	●	●	●	●	●	●
TPMT-FP	●	●	●	●	●	●

ISO catalogue number	D	L10	Re	KCP05	KCP10	KCP25	KCP30	KCP40	KCK05	KCK15	KCK20	KCM15	KCM25	KCM35	KU10	K313	K68	KCS10	KCU10	KC5010	KC5510	KCU25	KC5025	KC5525	KC5410	KT315	KTP10
	mm	mm	mm																								
TPGT090202LF	5,56	9,63	0,2																								
TPGT090204LF	5,56	9,63	0,4																								
TPGT110201LF	6,35	11,00	0,1																								
TPGT110202LF	6,35	11,00	0,2																								
TPGT110204LF	6,35	11,00	0,4																								
TPGT110208LF	6,35	11,00	0,8																								
TPGT16T304LF	9,53	16,50	0,4																								
TPGT16T308LF	9,53	16,50	0,8																								

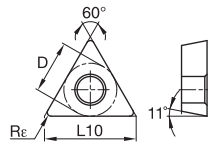

ISO catalogue number	D	L10	Re	KCP05	KCP10	KCP25	KCP30	KCP40	KCK05	KCK15	KCK20	KCM15	KCM25	KCM35	KU10	K313	K68	KCS10	KCU10	KC5010	KC5510	KCU25	KC5025	KC5525	KC5410	KT315	KTP10
	mm	mm	mm																								
TPHB110202	6,35	11,00	0,2																								
TPHB160304	9,53	16,50	0,4																								

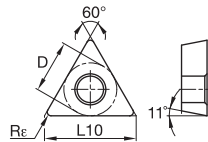
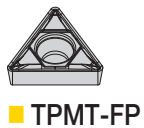

ISO catalogue number	D	L10	Re	KCP05	KCP10	KCP25	KCP30	KCP40	KCK05	KCK15	KCK20	KCM15	KCM25	KCM35	KU10	K313	K68	KCS10	KCU10	KC5010	KC5510	KCU25	KC5025	KC5525	KC5410	KT315	KTP10
	mm	mm	mm																								
TPMT090204FP	5,56	9,63	0,4																								
TPMT090208FP	5,56	9,63	0,8	●	●							●	●		●								●				●
TPMT110202FP	6,35	11,00	0,2																								
TPMT110204FP	6,35	11,00	0,4	●	●							●	●	●		●											
TPMT110208FP	6,35	11,00	0,8	●	●							●	●	●		●											●
TPMT110304FP	6,35	11,00	0,4																								
TPMT110308FP	6,35	11,00	0,8																								
TPMT16T304FP	9,53	16,50	0,4	●	●							●	●		●								●				●
TPMT16T308FP	9,53	16,50	0,8	●	●							●	●		●								●				●
TPMT16T312FP	9,53	16,50	1,2																								●
TPMT220408FP	12,70	22,00	0,8																								●



Inserts



■ TPMT-LF

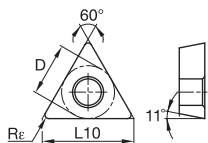

● first choice
○ alternate choice

ISO catalogue number	D mm	L10 mm	Re mm	Material Groups																						
				KCP05	KCP10	KCP25	KCP30	KCP40	KCK05	KCK15	KCK20	KCM15	KCM25	KCM35	KU10	K313	K68	KCS10	KCU10	KC5010	KC5510	KCU25	KC5025	KC5525	KC5410	KT315
TPMT090202LF	5,56	9,63	0,2																							
TPMT090204LF	5,56	9,63	0,4	●	●	●				●	●		●	●			●	●			●			●	●	
TPMT110202LF	6,35	11,00	0,2																							
TPMT110204LF	6,35	11,00	0,4	●	●	●				●	●	●	●	●			●	●			●			●	●	
TPMT110208LF	6,35	11,00	0,8	●	●	●				●	●	●	●	●												
TPMT16T304LF	9,53	16,50	0,4							●	●	●	●	●												
TPMT16T308LF	9,53	16,50	0,8	●	●	●				●	●	●	●	●												
TPMT16T312LF	9,53	16,50	1,2							●	●	●	●	●												
TPMT220408LF	12,70	22,00	0,8							●	●															

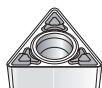

■ TPMT-MF

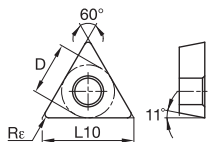

ISO catalogue number	D mm	L10 mm	Re mm	Material Groups																						
				KCP05	KCP10	KCP25	KCP30	KCP40	KCK05	KCK15	KCK20	KCM15	KCM25	KCM35	KU10	K313	K68	KCS10	KCU10	KC5010	KC5510	KCU25	KC5025	KC5525	KC5410	KT315
TPMT110208MF	6,35	11,00	0,8	●	●					●	●		●													
TPMT16T308MF	9,53	16,50	0,8	●	●	●				●	●	●	●													
TPMT16T312MF	9,53	16,50	1,2							●	●		●													



■ TPMT-MP

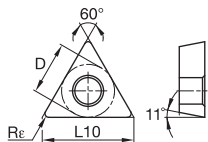

ISO catalogue number	D mm	L10 mm	Re mm	Material Groups																						
				KCP05	KCP10	KCP25	KCP30	KCP40	KCK05	KCK15	KCK20	KCM15	KCM25	KCM35	KU10	K313	K68	KCS10	KCU10	KC5010	KC5510	KCU25	KC5025	KC5525	KC5410	KT315
TPMT110208MP	6,35	11,00	0,8																							
TPMT16T308MP	9,53	16,50	0,8							●								●								
TPMT16T312MP	9,53	16,50	1,2							●			●													

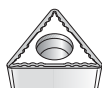

■ TPMT-UF

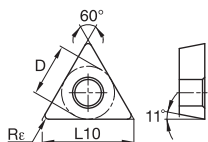

ISO catalogue number	D mm	L10 mm	Re mm	Material Groups																						
				KCP05	KCP10	KCP25	KCP30	KCP40	KCK05	KCK15	KCK20	KCM15	KCM25	KCM35	KU10	K313	K68	KCS10	KCU10	KC5010	KC5510	KCU25	KC5025	KC5525	KC5410	KT315
TPMT110202UF	6,35	11,00	0,2	●																						
TPMT110204UF	6,35	11,00	0,4	●	●																					
TPMT16T304UF	9,53	16,50	0,4							●																
TPMT16T308UF	9,53	16,50	0,8	●	●					●																

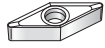

■ VBGT-HP

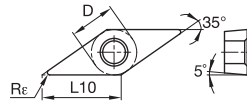

● first choice
○ alternate choice

ISO catalogue number	D mm	L10 mm	Re mm	Material Groups																						
				KCP05	KCP10	KCP25	KCP30	KCP40	KCK05	KCK15	KCK20	KCM15	KCM25	KCM35	KU10	K313	K68	KCS10	KCU10	KC5010	KC5510	KCU25	KC5025	KC5525	KC5410	KT315
VBGT110302HP	6,35	11,07	0,2																							
VBGT110304HP	6,35	11,07	0,4																							
VBGT160404HP	9,53	16,61	0,4																							
VBGT160408HP	9,53	16,61	0,8																							

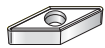

■ VBGT-LF

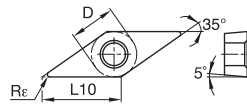

ISO catalogue number	D mm	L10 mm	Re mm	Material Groups																						
				KCP05	KCP10	KCP25	KCP30	KCP40	KCK05	KCK15	KCK20	KCM15	KCM25	KCM35	KU10	K313	K68	KCS10	KCU10	KC5010	KC5510	KCU25	KC5025	KC5525	KC5410	KT315
VBGT1103X0LF	6,35	11,07	0,0																							
VBGT110301LF	6,35	11,07	0,1																							
VBGT110302LF	6,35	11,07	0,2																							
VBGT110304LF	6,35	11,07	0,4																							
VBGT1604X0LF	9,53	16,61	0,0																							
VBGT160401LF	9,53	16,61	0,1																							
VBGT160402LF	9,53	16,61	0,2																							
VBGT160404LF	9,53	16,61	0,4																							

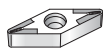

■ VBMT-11

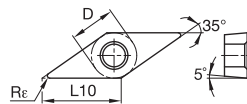

ISO catalogue number	D mm	L10 mm	Re mm	Material Groups																						
				KCP05	KCP10	KCP25	KCP30	KCP40	KCK05	KCK15	KCK20	KCM15	KCM25	KCM35	KU10	K313	K68	KCS10	KCU10	KC5010	KC5510	KCU25	KC5025	KC5525	KC5410	KT315
VBMT11030211	6,35	11,07	0,2																							
VBMT11030411	6,35	11,07	0,4																							
VBMT16040411	9,53	16,61	0,4																							
VBMT16040811	9,53	16,61	0,8																							



● first choice
○ alternate choice



■ VBMT-FP

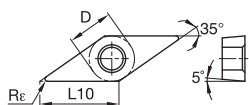

ISO catalogue number	D mm	L10 mm	Re mm	Material Groups																							
				KCP05	KCP10	KCP25	KCP30	KCP40	KCK05	KCK15	KCK20	KCM15	KCM25	KCM35	KU10	K313	K68	KCS10	KCU10	KC5010	KC5510	KCU25	KC5025	KC5525	KC5410	KT315	KTP10
VBMT110302FP	6,35	11,07	0,2																								
VBMT110304FP	6,35	11,07	0,4		●	●																					
VBMT110308FP	6,35	11,07	0,8			●																					
VBMT160402FP	9,53	16,61	0,2			●																					
VBMT160404FP	9,53	16,61	0,4	●	●	●																					
VBMT160408FP	9,53	16,61	0,8	●	●	●																					
VBMT160412FP	9,53	16,61	1,2			●																					



■ VBMT-LF

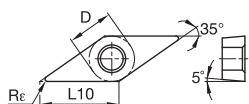

ISO catalogue number	D mm	L10 mm	Re mm	Material Groups																							
				KCP05	KCP10	KCP25	KCP30	KCP40	KCK05	KCK15	KCK20	KCM15	KCM25	KCM35	KU10	K313	K68	KCS10	KCU10	KC5010	KC5510	KCU25	KC5025	KC5525	KC5410	KT315	KTP10
VBMT110302LF	6,35	11,07	0,2																								
VBMT110304LF	6,35	11,07	0,4	●	●	●	●																				
VBMT110308LF	6,35	11,07	0,8	●	●	●	●																				
VBMT160402LF	9,53	16,61	0,2																								
VBMT160404LF	9,53	16,61	0,4	●	●	●	●																				
VBMT160408LF	9,53	16,61	0,8	●	●	●	●																				
VBMT160412LF	9,53	16,61	1,2					●																			



■ VBMT-MP

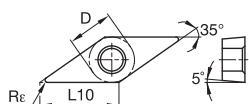

ISO catalogue number	D mm	L10 mm	Re mm	Material Groups																							
				KCP05	KCP10	KCP25	KCP30	KCP40	KCK05	KCK15	KCK20	KCM15	KCM25	KCM35	KU10	K313	K68	KCS10	KCU10	KC5010	KC5510	KCU25	KC5025	KC5525	KC5410	KT315	KTP10
VBMT160404MP	9,53	16,61	0,4			●																					
VBMT160408MP	9,53	16,61	0,8			●																					

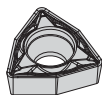

■ WCMT-FP

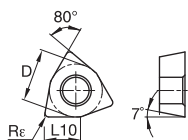

ISO catalogue number	D mm	L10 mm	Re mm	Material Groups																							
				KCP05	KCP10	KCP25	KCP30	KCP40	KCK05	KCK15	KCK20	KCM15	KCM25	KCM35	KU10	K313	K68	KCS10	KCU10	KC5010	KC5510	KCU25	KC5025	KC5525	KC5410	KT315	KTP10
WCMT040204FP	6,35	4,34	0,4																								
WCMT06T308FP	9,53	6,52	0,8			●																					

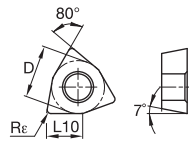

● first choice
○ alternate choice

ISO catalogue number	D mm	L10 mm	Re mm	Material Groups																						
				KCP05	KCP10	KCP25	KCP30	KCP40	KCK05	KCK15	KCK20	KCM15	KCM25	KCM35	KU10	K313	K68	KCS10	KCU10	KC5010	KC5510	KCU25	KC5025	KC5525	KC5410	KT315
WCMT040204LF	6,35	4,34	0,4																							
WCMT06T308LF	9,53	6,52	0,8																●			●			●	

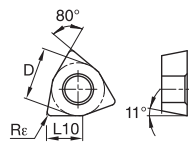
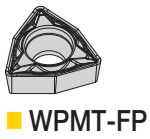

ISO catalogue number	D mm	L10 mm	Re mm	Material Groups																						
				KCP05	KCP10	KCP25	KCP30	KCP40	KCK05	KCK15	KCK20	KCM15	KCM25	KCM35	KU10	K313	K68	KCS10	KCU10	KC5010	KC5510	KCU25	KC5025	KC5525	KC5410	KT315
WPMTS3T104FP	4,76	3,25	0,4			●													●							
WPMT040204FP	6,35	4,34	0,4			●													●							
WPMT06T304FP	9,53	6,52	0,4			●													●							
WPMT06T308FP	9,53	6,52	0,8			●	●												●							

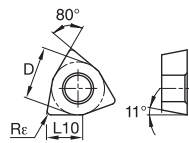

ISO catalogue number	D mm	L10 mm	Re mm	Material Groups																						
				KCP05	KCP10	KCP25	KCP30	KCP40	KCK05	KCK15	KCK20	KCM15	KCM25	KCM35	KU10	K313	K68	KCS10	KCU10	KC5010	KC5510	KCU25	KC5025	KC5525	KC5410	KT315
WPGTS30101UF	4,76	3,26	0,1																●	●						
WPGTS30102UF	4,76	3,26	0,2																●	●						
WPGT040202UF	6,35	4,34	0,2																●							

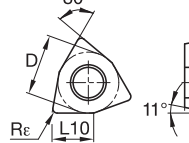

ISO catalogue number	D mm	L10 mm	Re mm	Material Groups																						
				KCP05	KCP10	KCP25	KCP30	KCP40	KCK05	KCK15	KCK20	KCM15	KCM25	KCM35	KU10	K313	K68	KCS10	KCU10	KC5010	KC5510	KCU25	KC5025	KC5525	KC5410	KT315
WPMTS3T104LF	4,76	3,25	0,4																●							
WPMT040204LF	6,35	4,34	0,4			●					●								●							
WPMT06T304LF	9,53	6,52	0,4			●	●				●	●							●							
WPMT06T308LF	9,53	6,52	0,8			●	●				●	●	●						●							





Ceramic Inserts



Primary Application

Kennametal's advanced materials, utilising Beyond™ technology, offer greater wear resistance and toughness, depending on the job.

KYK ceramic inserts are the first choice for high speed, continuous, and lightly interrupted turning applications in cast iron materials. Benefits include improved fracture toughness, better wear resistance, and extended application range. Combining KYK10™ and CVD-coated KYK25™ with our other ceramic grades for cast iron, Kennametal provides a complete, high-performance ceramic portfolio that can reduce machining cycle times and lower manufacturing costs.

KYS ceramic inserts are the first choice for high-speed applications in high-temp alloys. The multilayer coating offers enhanced chemical wear resistance versus uncoated grades. A superior sialon ceramic substrate provides excellent depth of cut notching resistance versus whisker-reinforced ceramics.

Features and Benefits

KYK10

- Improved wear resistance and toughness with 20% longer tool life than current KY1310™.
- Best suited for continuous turning of cast iron materials and in lightly interrupted cuts.
- Available in Kenloc™, Kendex™, and Top Notch™ turning insert styles.

KYK25

- 12 micron thick coating provides excellent wear resistance and pre-coat treatment allows for very consistent tool life and performance in cast iron applications.
- Up to 30% longer tool life vs. competitors' CVD-coated ceramic grades.
- Available in Kenloc, Kendex, and Top Notch turning insert styles.

KY3500™

- The industry standard for high-speed turning.
- Excellent for roughing to finishing operations in wet or dry cuts with speeds up to 1.040 m/min.
- Performs well in difficult interrupted cuts in ductile or malleable cast iron (<70 KSI tensile strength) at speeds of 275–500 m/min.



KYS25™

- Excellent surface finish, lower cutting forces, higher speeds.
- Advanced CVD coating provides excellent chemical and depth-of-cut notch resistance.

KYS30™

- Long, consistent tool life.
- Excellent toughness and depth-of-cut notch resistance.
- Performs in a wide variety of machining conditions, including interrupted cuts and applications involving scale.

Inserts

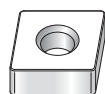

■ CNGA

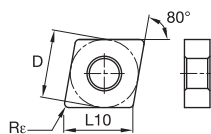

● first choice
○ alternate choice

P										
M										
K										
N										
S										
H	○									

ISO catalogue number	D mm	L10 mm	Rε mm	KYS25	KYS30	KY4300	KYK10	KYK25	KY3500	KY4400
CNGA120404E	12,70	12,90	0,4							
CNGA120408E	12,70	12,90	0,8	●	●					
CNGA120408T01020	12,70	12,90	0,8	●	●					
CNGA120408T02020	12,70	12,90	0,8				●	●	●	
CNGA120412E	12,70	12,90	1,2							
CNGA120412E	12,70	12,90	1,2	●	●					●
CNGA120412T01020	12,70	12,90	1,2	●	●					●
CNGA120412T02020	12,70	12,90	1,2				●	●	●	
CNGA120416E	12,70	12,90	1,6	●	●					
CNGA120416T01020	12,70	12,90	1,6							●
CNGA120416T02020	12,70	12,90	1,6				●	●	●	
CNGA160612T01020	15,88	16,12	1,2							●
CNGA160612T02020	15,88	16,12	1,2					●	●	
CNGA160616T02020	15,88	16,12	1,6					●	●	
CNGA190612T01020	19,05	19,34	1,2	●	●					
CNGA190612T02020	19,05	19,34	1,2			●		●	●	
CNGA190616T01020	19,05	19,34	1,6							●
CNGA190616T02020	19,05	19,34	1,6					●	●	



■ CNGA-FW

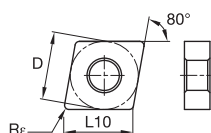

ISO catalogue number	D mm	L10 mm	Rε mm	KYS25	KYS30	KY4300	KYK10	KYK25	KY3500	KY4400
CNGA120404EFW	12,70	12,90	0,4							●
CNGA120408EFW	12,70	12,90	0,8							●
CNGA120408T01020FW	12,70	12,90	0,8					●	●	
CNGA120412EFW	12,70	12,90	1,2							●
CNGA120412T01020FW	12,70	12,90	1,2					●	●	●
CNGA120412T02020FW	12,70	12,90	1,2				●			
CNGA120416T01020FW	12,70	12,90	1,6							●

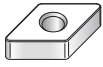

■ DNGA

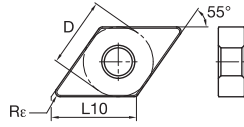

● first choice
○ alternate choice

P							
M							
K							
N							
S	●	●	●				
H	○	●					

ISO catalogue number	D	L10	Rε							
	mm	mm	mm	KYS25	KYS30	KY4300	KYK10	KYK25	KY3500	KY4400
DNGA150404E	12,70	15,50	0,4							●
DNGA150404T01020	12,70	15,50	0,4							●
DNGA150408E	12,70	15,50	0,8							●
DNGA150408T01020	12,70	15,50	0,8	●	●					●
DNGA150408T02020	12,70	15,50	0,8					●	●	●
DNGA150412T01020	12,70	15,50	1,2	●	●					●
DNGA150412T02020	12,70	15,50	1,2					●	●	●
DNGA150416T01020	12,70	15,50	1,6							●
DNGA150416T02020	12,70	15,50	1,6					●	●	●
DNGA150424T01020	12,70	15,50	2,4			●				
DNGA150608T01020	12,70	15,50	0,8							●
DNGA150608T02020	12,70	15,50	0,8						●	
DNGA150612T01020	12,70	15,50	1,2							●
DNGA150612T02020	12,70	15,50	1,2						●	
DNGA150616T01020	12,70	15,50	1,6							●
DNGA150616T02020	12,70	15,50	1,6						●	

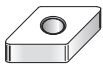

■ DNGA-FW

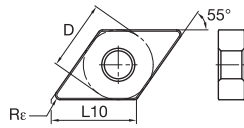

ISO catalogue number	D	L10	Rε							
	mm	mm	mm	KYS25	KYS30	KY4300	KYK10	KYK25	KY3500	KY4400
DNGA150408EFW	12,70	15,50	0,8							●
DNGA150412EFW	12,70	15,50	1,2							●

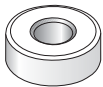

■ RNGA

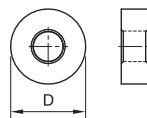

ISO catalogue number	D	L10	Rε							
	mm	mm	mm	KYS25	KYS30	KY4300	KYK10	KYK25	KY3500	KY4400
RNGA120400T01525	12,70	—	—							●



Inserts



■ SNGA

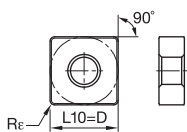

● first choice
○ alternate choice

P										
M										
K										
N										
S										
H										

ISO catalogue number	D mm	L10 mm	Re mm							
				KYS25	KYS30	KY4300	KYK10	KYK25	KY3500	KY4400
SNGA120408T01020	12,70	12,70	0,8							
SNGA120408T02020	12,70	12,70	0,8							
SNGA120412T01020	12,70	12,70	1,2							
SNGA120412T02020	12,70	12,70	1,2							
SNGA120416T01020	12,70	12,70	1,6							
SNGA120416T02020	12,70	12,70	1,6							
SNGA150612T02020	15,88	15,88	1,2							
SNGA150612T02020	15,88	15,88	1,2							
SNGA150616T02020	15,88	15,88	1,6							
SNGA190612T02020	19,05	19,05	1,2							
SNGA190616T02020	19,05	19,05	1,6							



■ TNGA

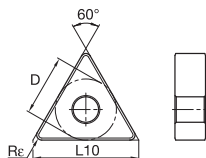

ISO catalogue number	D mm	L10 mm	Re mm							
				KYS25	KYS30	KY4300	KYK10	KYK25	KY3500	KY4400
TNGA160404E	9,53	16,50	0,4							
TNGA160404T01020	9,53	16,50	0,4							
TNGA160408E	9,53	16,50	0,8							
TNGA160408T01020	9,53	16,50	0,8							
TNGA160408T02020	9,53	16,50	0,8							
TNGA160412T01020	9,53	16,50	1,2							
TNGA160412T02020	9,53	16,50	1,2							
TNGA160416T02020	9,53	16,50	1,6							
TNGA220408T01020	12,70	22,00	0,8							
TNGA220412T01020	12,70	22,00	1,2							
TNGA220412T02020	12,70	22,00	1,2							
TNGA220416T02020	12,70	22,00	1,6							

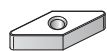

■ VNGA

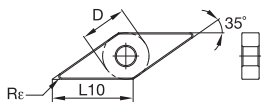

ISO catalogue number	D mm	L10 mm	Re mm							
				KYS25	KYS30	KY4300	KYK10	KYK25	KY3500	KY4400
VNGA160404T01020	9,53	16,61	0,4							
VNGA160408T01020	9,53	16,61	0,8							
VNGA160408T02020	9,53	16,61	0,8							
VNGA220408T02020	12,70	22,14	0,8							

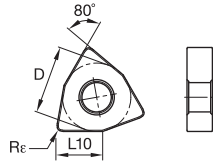

● first choice
○ alternate choice

P						
M						
K						
N				●	●	●
S	●	●	●			
H	○	●				●



Inserts

ISO catalogue number	D	L10	Rε							
	mm	mm	mm	KYS25	KYS90	KY4300	KYK10	KYK25	KY3500	KY4400
WNGA080404T01020	12,70	8,69	0,4							
WNGA080408EFW	12,70	8,69	0,8							●
WNGA080408T01020	12,70	8,69	0,8		●					●
WNGA080408T01020FW	12,70	8,69	0,8						●	●
WNGA080408T02020	12,70	8,69	0,8					●	●	●
WNGA080412EFW	12,70	8,69	1,2							●
WNGA080412T01020	12,70	8,69	1,2							●
WNGA080412T01020FW	12,70	8,69	1,2							●
WNGA080412T02020	12,70	8,69	1,2			●	●	●	●	●
WNGA080416T01020	12,70	8,69	1,6		●					
WNGA080416T02020	12,70	8,69	1,6					●	●	

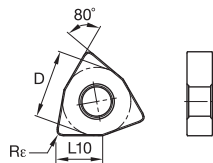

ISO catalogue number	D	L10	Rε							
	mm	mm	mm	KYS25	KYS90	KY4300	KYK10	KYK25	KY3500	KY4400
WNGA080408EFW	12,70	8,69	0,8							●
WNGA080408T01020FW	12,70	8,69	0,8						●	●
WNGA080412EFW	12,70	8,69	1,2							●
WNGA080412T01020FW	12,70	8,69	1,2							●



Inserts



■ CNGN

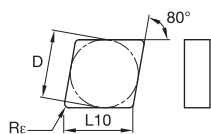

● first choice
○ alternate choice

P							
M							
K							
N							
S							
H	○						

	D	L10	Re							
ISO catalogue number	mm	mm	mm	KYS25	KYS30	KY4300	KYK10	KYK25	KY3500	KY4400
CNGN120404T01020	12,70	12,90	0,4							
CNGN120408T01020	12,70	12,90	0,8	●	●					●
CNGN120408T02020	12,70	12,90	0,8				●		●	
CNGN120412E	12,70	12,90	1,2	●	●					
CNGN120412T01020	12,70	12,90	1,2	●	●					●
CNGN120412T02020	12,70	12,90	1,2				●	●	●	
CNGN120416E	12,70	12,90	1,6	●	●					
CNGN120416T01020	12,70	12,90	1,6	●	●					
CNGN120416T02020	12,70	12,90	1,6						●	
CNGN120708T01020	12,70	12,90	0,8			●				●
CNGN120712T01020	12,70	12,90	1,2	●	●	●				●
CNGN120712T02020	12,70	12,90	1,2					●	●	
CNGN120716T01020	12,70	12,90	1,6	●	●					●
CNGN120716T02020	12,70	12,90	1,6				●		●	
CNGN160412T02020	15,88	16,12	1,2						●	
CNGN160716T02020	15,88	16,12	1,6						●	

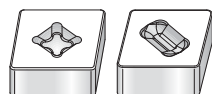

■ CNGX

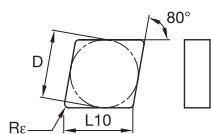

	D	L10	Re							
ISO catalogue number	mm	mm	mm	KYS25	KYS30	KY4300	KYK10	KYK25	KY3500	KY4400
CNGX120708T01020	12,70	12,90	0,8	●	●					
CNGX120708T02020	12,70	12,90	0,8					●	●	●
CNGX120712E	12,70	12,90	1,2		●					
CNGX120712T01020	12,70	12,90	1,2	●	●					
CNGX120712T02020	12,70	12,90	1,2					●	●	●
CNGX120716E	12,70	12,90	1,6		●					
CNGX120716T02020	12,70	12,90	1,6					●	●	●
CNGX160716T02020	15,88	16,12	1,6					●	●	●

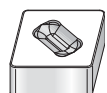

■ CNGX-FW

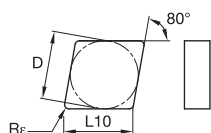

	D	L10	Re							
ISO catalogue number	mm	mm	mm	KYS25	KYS30	KY4300	KYK10	KYK25	KY3500	KY4400
CNGX120708T01020FW	12,70	12,90	0,8							●
CNGX120712T01020FW	12,70	12,90	1,2							●
CNGX120716T01020FW	12,70	12,90	1,6							●



Inserts

● first choice
○ alternate choice

P	■	■	■	■	■	■
M	■	■	■	■	■	■
K	■	■	■	●	●	●
N	■	■	■	■	■	■
S	●	●	●	■	■	■
H	○	○	○	○	○	○

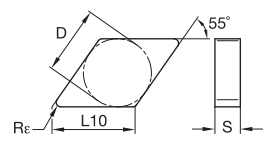

	D	L10	Rε	KYS25	KYS30	KY4300	KYK10	KYK25	KY3500	KY4400
ISO catalogue number	mm	mm	mm							
DNGN150412T01020	12,70	15,50	1,2							
DNGN150704T01020	12,70	15,50	0,4							●
DNGN150708T01020	12,70	15,50	0,8			●				●
DNGN150712T01020	12,70	15,50	1,2			●				●
DNGN150716T01020	12,70	15,50	1,6			●				●

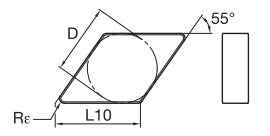

	D	L10	Rε	KYS25	KYS30	KY4300	KYK10	KYK25	KY3500	KY4400
ISO catalogue number	mm	mm	mm							
DNGX120708T02020	10,00	12,21	0,8							●
DNGX120712T02020	10,00	12,21	1,2					●	●	
DNGX120716T02020	10,00	12,21	1,6					●	●	
DNGX150708T01020	12,70	15,50	0,8	●	●					
DNGX150708T02020	12,70	15,50	0,8				●			●
DNGX150712T01020	12,70	15,50	1,2	●	●					
DNGX150712T02020	12,70	15,50	1,2					●	●	
DNGX150716T01020	12,70	15,50	1,6	●	●					
DNGX150716T02020	12,70	15,50	1,6							●

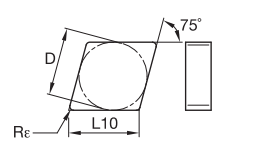

	D	L10	Rε	KYS25	KYS30	KY4300	KYK10	KYK25	KY3500	KY4400
ISO catalogue number	mm	mm	mm							
ENGN130412T02020	12,70	13,15	1,2							●
ENGN130708T01020	12,70	13,15	0,8			●				
ENGN130712T01020	12,70	13,15	1,2			●				
ENGN130712T02020	12,70	13,15	1,2							●
ENGN130716T02020	12,70	13,15	1,6							●



Inserts

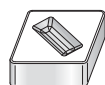

■ ENGX

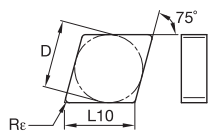

● first choice
○ alternate choice

P									
M									
K									
N									
S									
H	○								

	D	L10	Rε	KYS25	KYS30	KY4300	KYK10	KYK25	KY3500	KY4400
ISO catalogue number	mm	mm	mm							
ENGX130716T02020	12,70	13,15	1,6						●	



■ RNGN

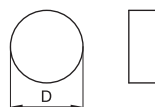

	D	L10	Rε	KYS25	KYS30	KY4300	KYK10	KYK25	KY3500	KY4400
ISO catalogue number	mm	mm	mm							
RNGN090300T01020	9,53	—	—			●				
RNGN090400T00520	9,53	—	—			●				
RNGN120300T01020	12,70	—	—							●
RNGN120400E	12,70	—	—	●	●					
RNGN120400T01020	12,70	—	—	●	●					●
RNGN120400T02020	12,70	—	—				●	●	●	
RNGN120700E	12,70	—	—	●	●					
RNGN120700T00520	12,70	—	—			●				
RNGN120700T00525	12,70	—	—			●				
RNGN120700T01020	12,70	—	—	●	●					●
RNGN120700T01025	12,70	—	—	●	●					
RNGN120700T02020	12,70	—	—				●	●	●	
RNGN120700T10015	12,70	—	—			●				
RNGN120700T15015	12,70	—	—			●				
RNGN150700T02020	15,88	—	—							●
RNGN150700T20015	15,88	—	—			●				
RNGN190700E	19,05	—	—	●	●					
RNGN190700T01020	19,05	—	—	●	●					
RNGN190700T20015	19,05	—	—			●				
RNGN250700T01020	25,40	—	—			●				
RNGN250700T20015	25,40	—	—			●				
RNGN250900E	25,40	—	—	●						



■ SNGN

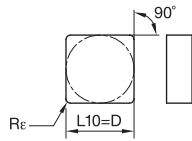

● first choice
○ alternate choice

P										
M										
K										
N										
S										
H	○									

ISO catalogue number	D mm	L10 mm	Rε mm	KYS25	KYS30	KY4300	KVK10	KYK25	KY3500	KY4400
SNGN090308T01020	9,53	9,53	0,8							
SNGN090308T02020	9,53	9,53	0,8							
SNGN090312T01020	9,53	9,53	1,2							
SNGN120408T01020	12,70	12,70	0,8							
SNGN120408T02020	12,70	12,70	0,8							
SNGN120412T01020	12,70	12,70	1,2							
SNGN120412T02020	12,70	12,70	1,2							
SNGN120416T01020	12,70	12,70	1,6							
SNGN120416T02020	12,70	12,70	1,6							
SNGN120424T02020	12,70	12,70	2,4							
SNGN120432T02020	12,70	12,70	3,2							
SNGN120704T01020	12,70	12,70	0,4							
SNGN120708T01020	12,70	12,70	0,8							
SNGN120712T01020	12,70	12,70	1,2							
SNGN120712T02020	12,70	12,70	1,2							
SNGN120716T01020	12,70	12,70	1,6							
SNGN120716T02020	12,70	12,70	1,6							
SNGN120720T05020	12,70	12,70	2,0							
SNGN150712T02020	15,88	15,88	1,2							
SNGN190412T02020	19,05	19,05	1,2							
SNGN190416T02020	19,05	19,05	1,6							
SNGN190616E	19,05	19,05	1,6							
SNGN190616T01020	19,05	19,05	1,6							
SNGN190716T20015	19,05	19,05	1,6							
SNGN190720T10015	19,05	19,05	2,0							
SNGN190724E	19,05	19,05	2,4							
SNGN190724T20015	19,05	19,05	2,4							

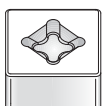

■ SNGX

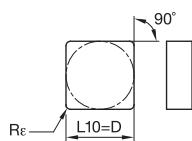

ISO catalogue number	D mm	L10 mm	Rε mm	KYS25	KYS30	KY4300	KVK10	KYK25	KY3500	KY4400
SNGX120708T01020	12,70	12,70	0,8							
SNGX120708T02020	12,70	12,70	0,8							
SNGX120712T01020	12,70	12,70	1,2							
SNGX120712T02020	12,70	12,70	1,2							
SNGX120716T01020	12,70	12,70	1,6							
SNGX120716T02020	12,70	12,70	1,6							
SNGX150712T02020	15,88	15,88	1,2							
SNGX150716T02020	15,88	15,88	1,6							
SNGX150724T02020	15,88	15,88	2,4							



Inserts



■ SNGX-FW

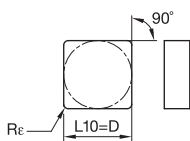

● first choice
○ alternate choice

P							
M							
K					●	●	●
N							
S	●	●	●				
H	○		●				●

	D	L10	Re								
ISO catalogue number	mm	mm	mm		KYS25	KYS30	KY4300	KYK10	KYK25	KY3500	KY4400
SNGX120712T01020FW	12,70	12,70	1,2					●		●	



■ TNGN

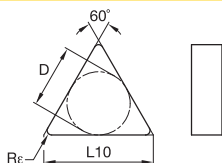

	D	L10	Re								
ISO catalogue number	mm	mm	mm		KYS25	KYS30	KY4300	KYK10	KYK25	KY3500	KY4400
TNGN110308T01020	6,35	11,00	0,8								●
TNGN160408T01020	9,53	16,50	0,8				●				●
TNGN160408T02020	9,53	16,50	0,8							●	
TNGN160708T01020	9,53	16,50	0,8				●				●
TNGN160412T01020	9,53	16,50	1,2				●				●
TNGN160412T02020	9,53	16,50	1,2							●	
TNGN160712T01020	9,53	16,50	1,2								●
TNGN220408T01020	12,70	22,00	0,8								●
TNGN220408T02020	12,70	22,00	0,8								●
TNGN220412T01020	12,70	22,00	1,2		●	●					
TNGN220416T01020	12,70	22,00	1,6		●	●					
TNGN220416T02020	12,70	22,00	1,6						●	●	

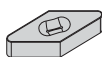

■ VNGX

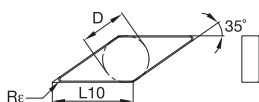

	D	L10	Re								
ISO catalogue number	mm	mm	mm		KYS25	KYS30	KY4300	KYK10	KYK25	KY3500	KY4400
VNGX160712T02020	9,53	16,61	1,2								●
VNGX160716T02020	9,53	16,61	1,6								●



■ WNGX

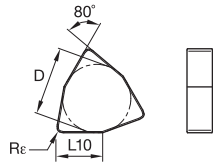

● first choice
○ alternate choice

P									
M									
K									
N									
S									
H									

	D	L10	Re							
ISO catalogue number	mm	mm	mm	KYS25	KYS30	KY4300	KYK10	KYK25	KY3500	KY4400
WNGX080708T02020	12,70	8,69	0,8							
WNGX080712T02020	12,70	8,69	1,2							
WNGX080716T02020	12,70	8,69	1,6							



■ WNGX-FW

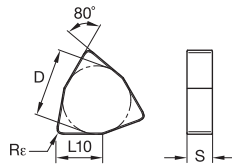

	D	L10	Re							
ISO catalogue number	mm	mm	mm	KYS25	KYS30	KY4300	KYK10	KYK25	KY3500	KY4400
WNGX080708T01020FW	12,70	8,69	0,8							
WNGX080712T01020FW	12,70	8,69	1,2							
WNGX080716T01020FW	12,70	8,69	1,6							



Inserts



■ RCGX

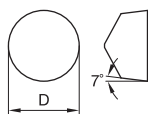

● first choice
○ alternate choice

P										
M										
K										
N										
S										
H	○									

ISO catalogue number	D mm	L10 mm	R _ε mm	KYS25	KYS30	KY4300	KYK10	KYK25	KY3500	KY4400
RCGX060400E	6,35	—	—	●	●					
RCGX060400T01020	6,35	—	—			●				
RCGX090700E	9,53	—	—	●	●					
RCGX090700T00525	9,53	—	—		●					
RCGX090700T01020	9,53	—	—	●	●					
RCGX120700E	12,70	—	—	●	●					●
RCGX120700E	12,70	—	—	●	●					
RCGX120700S20015	12,70	—	—							●
RCGX120700T01020	12,70	—	—	●	●	●				●
RCGX120700T01025	12,70	—	—	●	●	●				
RCGX151000T20015	15,88	—	—			●				
RCGX191000T20015	19,05	—	—			●				
RCGX251200T20015	25,40	—	—			●				

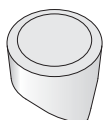

■ RCGV-T

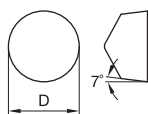

ISO catalogue number	D mm	L10 mm	R _ε mm	KYS25	KYS30	KY4300	KYK10	KYK25	KY3500	KY4400
RCGX060600T00520	6,35	—	—					●		



■ RPGN

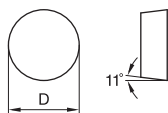

ISO catalogue number	D mm	L10 mm	R _ε mm	KYS25	KYS30	KY4300	KYK10	KYK25	KY3500	KY4400
RPGN060200E	6,35	—	—		●					
RPGN090300E	9,53	—	—	●						
RPGN090300T00520	9,53	—	—					●		
RPGN090300T01020	9,53	—	—					●		
RPGN120400E	12,70	—	—		●					
RPGN120400T01020	12,70	—	—		●					



Inserts

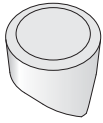

■ RPGX

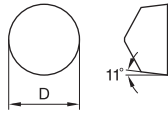

● first choice
○ alternate choice

P							
M							
K							
N							
S							
H							

ISO catalogue number	D	L10	R _ε							
	mm	mm	mm	KYS25	KYS90	KY4300	KYK10	KYK25	KY3500	KY4400
RPGX060400T00520	6,35	—	—							
RPGX060400T01020	6,35	—	—							
RPGX090700E	9,53	—	—							
RPGX090700T00520	9,53	—	—							
RPGX090700T01020	9,53	—	—							
RPGX120700E	12,70	—	—							
RPGX120700T00520	12,70	—	—							
RPGX120700T01020	12,70	—	—							



■ SCGN-FW

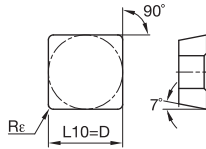

ISO catalogue number	D	L10	R _ε							
	mm	mm	mm	KYS25	KYS90	KY4300	KYK10	KYK25	KY3500	KY4400
SCGN090408EFW	9,53	9,53	0,8							
SCGN090408EFW	9,53	9,53	0,8							

C2-C71	C72-C109	C110-C115	C116-C147	B10-B23	B24-B31	B32-B37

Inserts



■ SPSGN

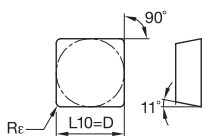

● first choice
○ alternate choice

P									
M									
K									
N									
S									
H									

	D	L10	Rε							
ISO catalogue number	mm	mm	mm	KYS25	KYS30	KY4300	KYK10	KYK25	KY3500	KY4400
SPGN090308T01020	9,53	9,53	0,8							
SPGN120308T01020	12,70	12,70	0,8							



■ TPGN

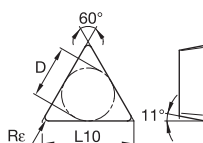

	D	L10	Rε							
ISO catalogue number	mm	mm	mm	KYS25	KYS30	KY4300	KYK10	KYK25	KY3500	KY4400
TPGN110304T01020	6,35	11,00	0,4							
TPGN110308T00520	6,35	11,00	0,8							
TPGN110308T01020	6,35	11,00	0,8							
TPGN160304T01020	9,53	16,50	0,4							
TPGN160308T00520	9,53	16,50	0,8							
TPGN160308T01020	9,53	16,50	0,8							
TPGN160308T02020	9,53	16,50	0,8							
TPGN160312T01020	9,53	16,50	1,2							
TPGN160312T02020	9,53	16,50	1,2							
TPGN220408T02020	12,70	22,00	0,8							
TPGN220412T02020	12,70	22,00	1,2							



Beyond™ ISO

Ceramic Insert Expansion

KYK10™, KYK25™, KYS25™, and KYS30™

The new Beyond ISO KYK Ceramic Inserts are the first choice for high speed, continuous, and lightly interrupted turning applications in grey cast iron. These premium ceramic solutions for continuous cast iron turning applications offer improved fracture toughness, better wear resistance, and extended application range. By combining KYK10 and CVD-coated KYK25 with Kennametal's other ceramic grades for cast iron materials, Kennametal provides a complete, high-performance ceramic portfolio that can be optimised to reduce machining cycle times and lower overall manufacturing costs.

KYK10:

- Best suited for continuous turning of cast iron materials and in lightly interrupted cuts.

KYK25:

- Excellent wear resistance and pre-coat treatment allows for very consistent tool life and performance in a multitude of cast iron applications.

KYS25:

- Excellent surface finish, lower cutting forces, higher speeds.

KYS30:

- Excellent toughness and depth-of-cut notch resistance.

Experience the advantages at your Authorised Kennametal Distributor or at www.kennametal.com.

www.kennametal.com



Superhard Materials • PCBN and PCD

Superhard Tool Materials	B133–B173
Application Areas	B134–B135
PCBN	B137–B163
PCD	B165–B173
Superhard Inserts	B174–B197

■ Properties of PCD and PCBN cutting tool materials

The current global metalcutting climate has put increased focus on high productivity and cost reductions coming from cutting tools. These requirements lead to the rapid growth and implementation of cutting tools using superhard materials. As the name implies, these materials have a significant advantage in hardness over conventional tool materials, which from the end user point of view, translates into increased productivity (higher cutting speeds, longer tool life, etc.), lower tooling cost per part, and also, the ability to process materials previously un-machinable with conventional tooling.

The most widely known superhard materials are diamond and cubic boron nitride. Our industry uses the polycrystalline forms of these materials, i.e., polycrystalline diamond (PCD) and polycrystalline boron nitride (PCBN). PCD tooling is mainly targeted at the machining of non-ferrous materials (e.g., aluminum alloys, plastics, CFRPs, composites, titanium alloys, ceramics, carbides, etc.) whereas PCBN targets iron-based alloys (e.g., cast irons, hard steels, iron-based composites, etc.)

Kennametal is at the forefront of developing and implementing superhard materials in our standard and special tooling solutions across all our product lines. Kennametal's approach to superhard tooling starts with customer needs and constraints. We then use fundamental research to develop the best superhard solutions that would make available the best value for the customer and respond to their specific demands.

■ Where to use PCD and PCBN

Diamond and cubic boron nitride (CBN) are the most commonly known superhard materials. For cutting tools, they are used in their polycrystalline form, i.e., PCD and PCBN.

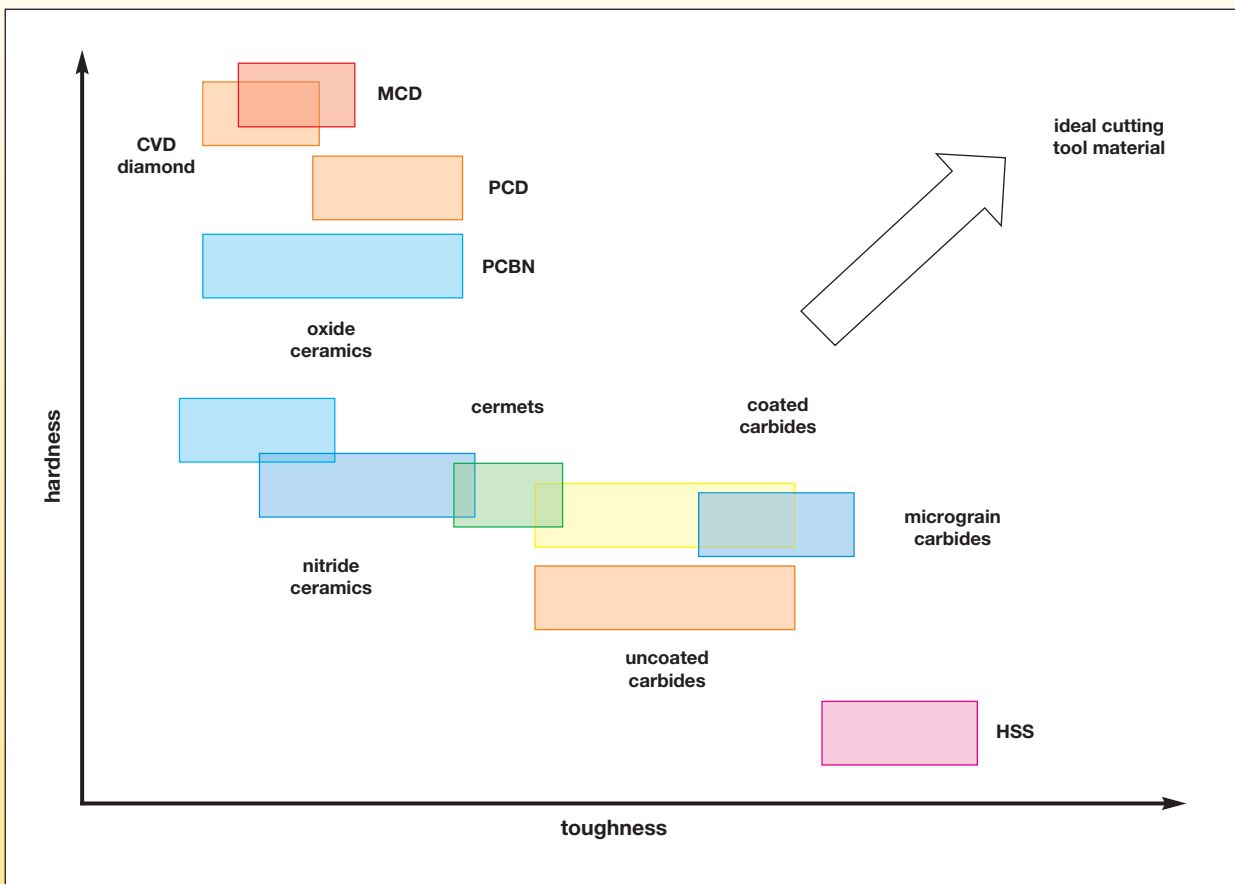

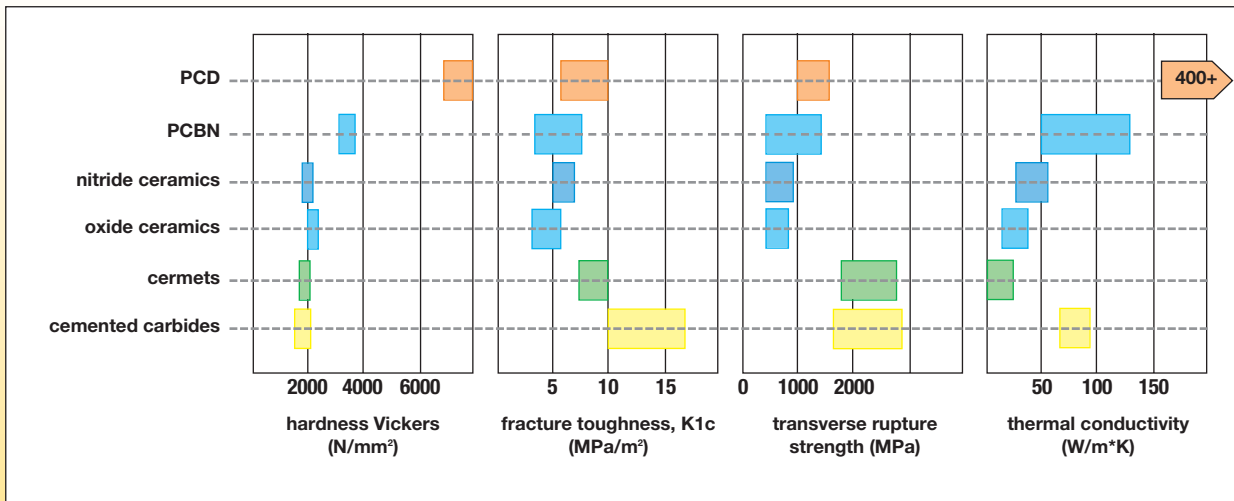

PCBN/PCD Inserts

■ Choosing between PCD and PCBN

It is primarily their thermochemical stability that determines the suitability of the two materials for specific areas of application. For standard PCD, this means that it is restricted to workpiece materials where the cutting temperature does not exceed 700 °C and has no affinity with carbon if diffusion wear of the cutting edge is to be avoided at elevated temperatures. Operations that satisfy these conditions are, for example, the machining of non-ferrous metals, wood, plastics, and minerals where PCD mainly competes against tungsten carbide and, to some extent, high-speed steel.

By contrast, PCBN is thermally stable up to approximately 1200 °C and has high resistance to chemical attack. As a result, extreme temperatures, such as occur when machining hard ferrous metals, do not pose difficulties and can be used to promote self-induced hot cutting. Therefore, technical and economic benefits can be achieved, particularly in comparison with grinding, and in most cases, performance is significantly better than that attainable with conventional tool materials, such as tungsten carbides and ceramics.

There are limitations for PCBN, however, in the machining of austenitic steels and ferritic cast irons, where more reactive phases result in increased PCBN edge wear.



■ PCBN

Increased productivity can be achieved with PCBN tools through:

- Higher cutting speeds.
- Higher feed rates.
- Longer tool life.
- Less machine downtime.
- More parts per machine means direct tool costs can be reduced.
- Very tight workpiece surface finish tolerances can be achieved on difficult-to-machine materials.
- PCBN can be used to machine ferrous materials in the hardened condition as an alternative to grinding, making it possible to substantially reduce component machining times.
- PCBN offers environmental benefits — the generation of grinding sludge is eliminated and the chips can be recycled.
- Improved surface integrity of critical components.

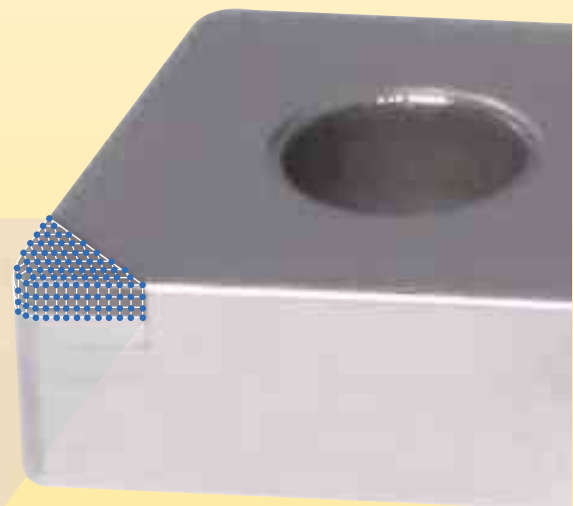

B Boron

N Nitrogen

■ Grinding vs. Hard Turning



Grinding

- Size tolerance specifications beyond the capability of turning.
- Surface finish requirements too tight for hard turning.



vs. Hard Turning

- Size tolerance specifications beyond the capability of turning.
- Complex geometry that makes single-point turning more practical.
- Relatively high metal removal rates.
- Dry machining.
- Faster machine setup.
- Faster cycle times.
- I.D. and O.D. machining on one machine.

■ Where does PCBN work?

PCBN is suitable for machining a wide variety of workpiece materials, mainly ferrous alloys.

The application areas may be broadly categorised as follows:

Hardened Steels	Cast Irons	Superalloys	Powder Metallurgy Steels

Certain classes of PCBN materials are associated with each particular application.

For best cost performance, proper selection of the following is essential:

- Format of the insert.
- Grade.
- Edge prep.
- Application data.

■ PCBN is known as the second hardest material

There are two principal material conditions where PCBN is used.

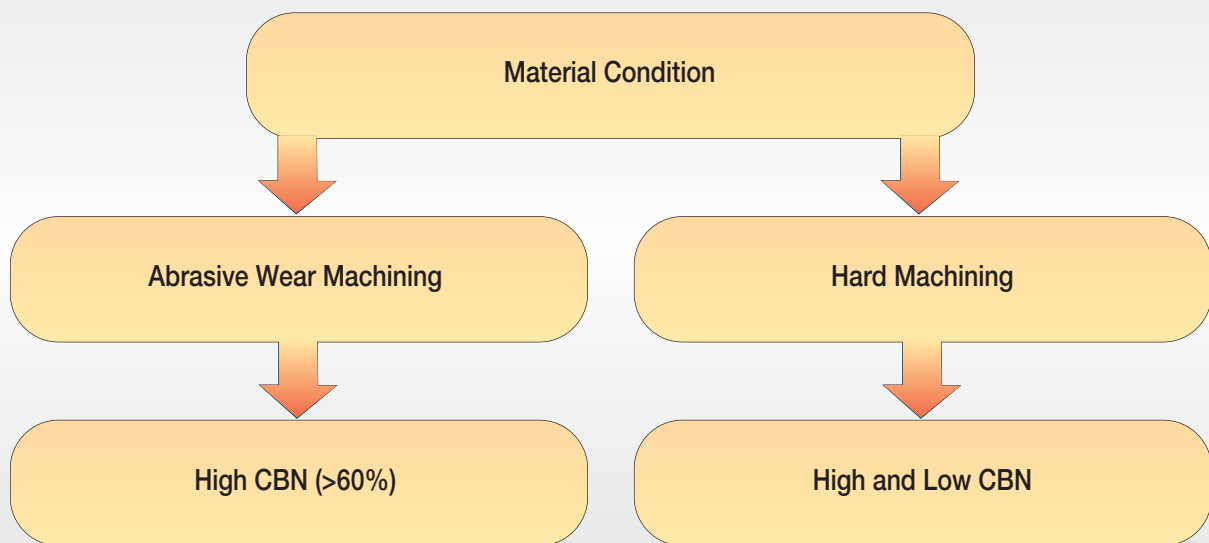

■ PCBN insert formats

Solid Inserts

- Inserts are made only from PCBN.
- No material joint.
- Best heat absorption capacity.
- Can work at highest temperatures.

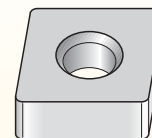

solid

Full-Face Inserts

- Inserts are made from a presintered carbide/PCD or PCBN joint.
- Elimination of the brazing joint. Less delamination.
- Better heat absorption capacity.
- Can work at higher temperatures than tipped tools.
- Facilitate larger depth of cut compared to the same size tipped insert.
- The blanks are available with “A” and “W” ISO-style pin-lock holes.

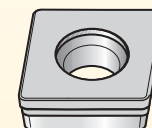

full-face

Tipped Inserts

- Require a carrier and substrate for the insert.
- The tips are brazed to the substrate. Various brazing methods are applied.
- The substrate has to have a pocket that will accommodate and support the tip.
- In these types of tools, the braze joint represents the weak link, so the brazing operation is very important and should be carefully controlled and executed.
- The main advantage of tipped tools over full-faced inserts is the lower cost.

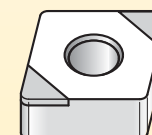

tipped

■ Kennametal inserts

This table shows approximate tip sizes of Kennametal CBN inserts depending on style and corner radius. Please note that the maximum cutting depth is not more than 80% of the tip length.

radius	insert shape				
	S	C, W	T	D, K	V
R 0,2mm					
R 0,4mm					
R 0,8mm					
R 1,2mm					
R 1,6mm					

■ PCBN portfolio

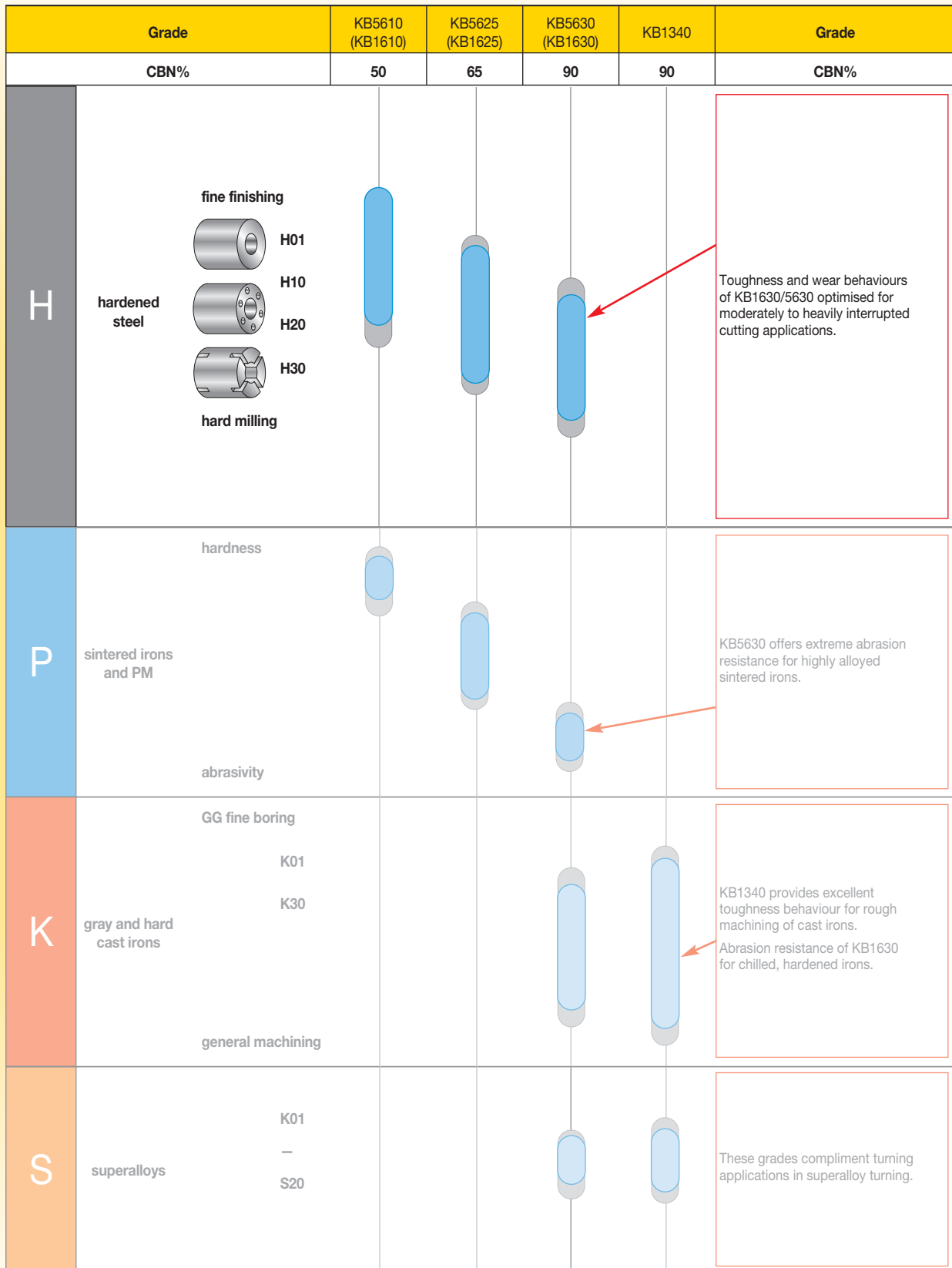

PCBN/PCD Inserts



PCBN Hard Turning Selection System

Introduction

This guide will help you choose the PCBN grade, edge preparations, nose radius, feed, and recommended speed range for your hard turning applications. These recommendations will establish a starting point for optimisation of the application. Where possible, this guide will lead you to standard line items. If this is not the case, the items can still be obtained through the QTSP (Quick-Turn Solutions Program) or ordered as specials.

We will classify hard turning operations as any turning or boring of ferrous-based workpiece materials with a hardness (HRC) higher than 45. For workpieces with lower hardness values, PCBN is not recommended.

To use the guide, you will need this application information:

- Workpiece design: interruptions, shape, and frequency.
- Workpiece material specifications: hardness, superficial or through treatment, and carbide forming alloying elements (that increase the abrasivity of the material).
- Depth of cut.
- Surface finish requirements.
- Preset conditions, such as specific nose radius, limited feed, etc.
- Setup limitations related to machine tool, fixturing, etc.
- Tool life criteria, e.g., surface finish, dimensional tolerance, cutting force, etc.

PCBN Hard Turning • Selection System Overview

Step 1 • Choosing the PCBN Grade



Step 1, reference page B144–B145.

Step 2 • PCBN Edge Preparation Features

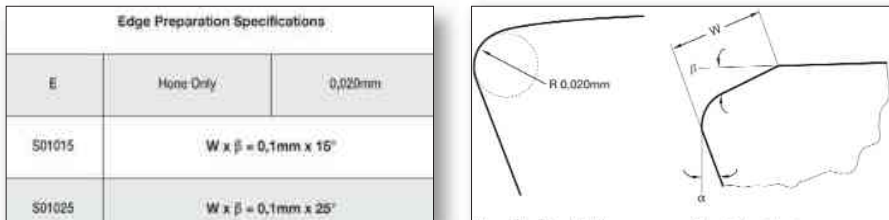

Step 2, reference page B145.

Step 3 • Selection of T-Land Angle

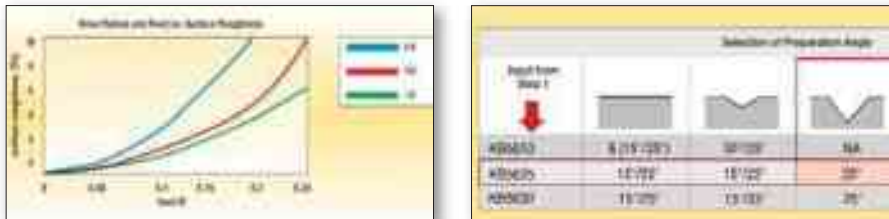

Step 3, reference page B145.

Step 4 • Selection of T-Land Width

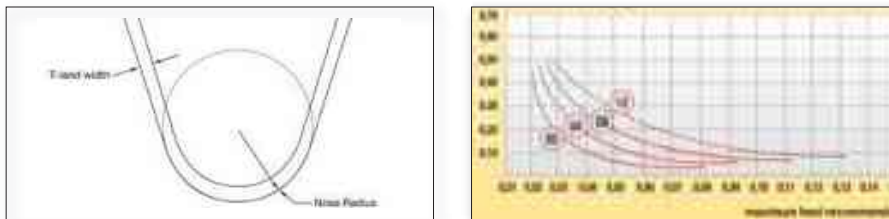

Step 4, reference page B146.

Step 5 • Choosing the Speed Range

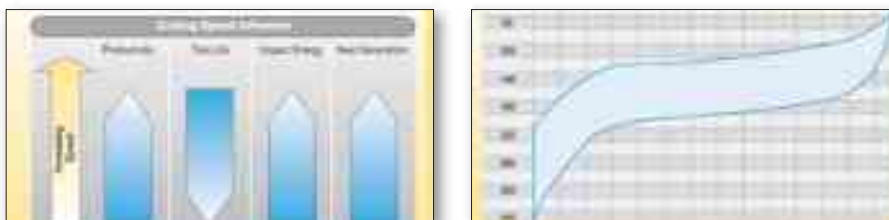

Step 5, reference page B147.

Grade Selection for Hard Turning

How to Use

Identify your application conditions. The most far right parameter will then determine the recommended grade(s). If more than one grade is intersected, it is recommended to first select the grade with the highest toughness (page B139) before optimising using the Troubleshooting Guide (pages B142–B143).

Step 1 • Choosing the PCBN grade

Depth of Cut (mm)

Larger depths of cut need stronger grades.

0.10 0.20 0.30 0.40 0.50 0.60 0.70

Continuous/Interrupted

More continuous cutting needs more crater wear resistance; more interrupts need more toughness.

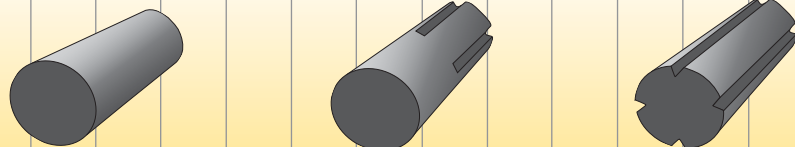

Interruption Severity

The angle between the cutting direction and the edge of the interruption has a big influence on the severity of an interrupt impact.

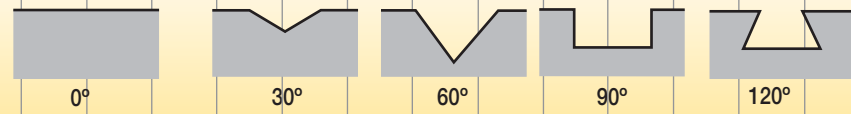

Interruption Frequency

A wide spacing between interrupts emphasises crater wear resistance, whereas closer-located interrupts emphasise impact resistance.

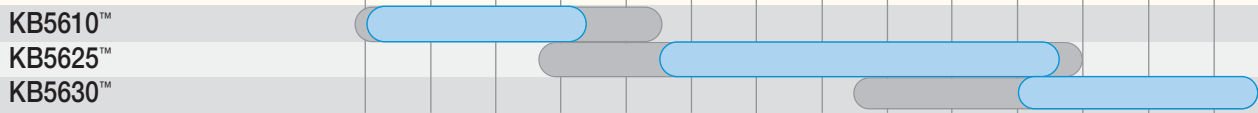
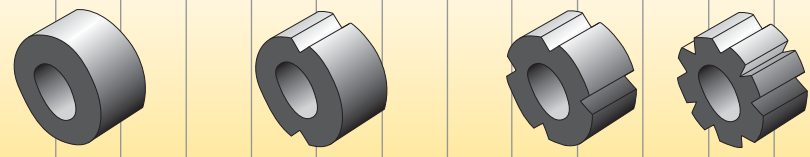

ISO Class Hard Turning

H10 H15 H20 H25 H30

Tool Wear Type

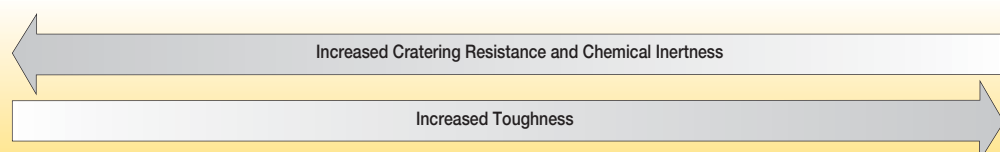

(continued)

Step 1 • Choosing the PCBN grade (continued)

	cratering resistance	abrasive resistance	impact resistance	surface finish
KB5610™	***	*	*	***
KB5625™	**	**	**	**
KB5630™	*	***	***	**

*** = Best

Step 2 • PCBN edge preparation features

Edge Preparation Specifications		
E	hone only	0,020mm
S01015	$W \times \beta = 0,1\text{mm} \times 15^\circ$	
S01025	$W \times \beta = 0,1\text{mm} \times 25^\circ$	

R 0,020mm

W — Edge Prep Width
 α — Clearance Angle
 β — T-Land Angle

Nose Radius and Feed vs. Surface Roughness

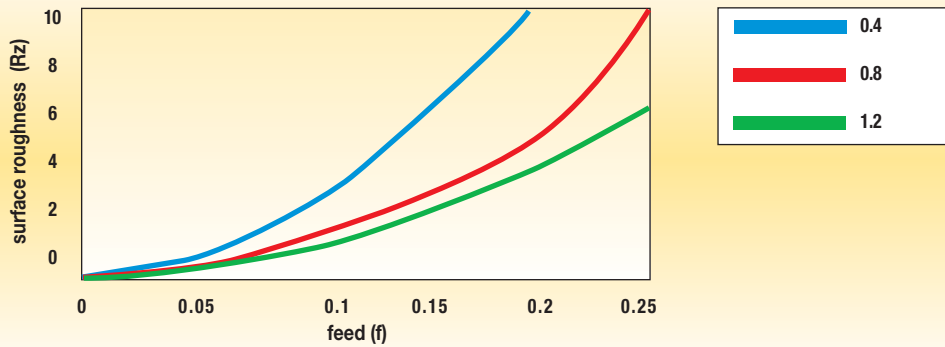

Step 3 • Selection of T-land angle

How to Use

Using the grade selection and the Interruption Severity from Step 1, select edge preparation angle or hone only, E, from the table below. Solutions in parenthesis are second options.

Selection of Preparation Angle					
input from Step 1 ↓					
KB5610	E (15°/25°)	20°/25°	NA	NA	NA
KB5625	15°/25°	15°/25°	20°/25°	25°	NA
KB5630	15°/25°	15°/25°	20°/25°	25°	25°/35°

Step 4 • Selection of T-land width

How to Use

Example 1: If the feed, depth of cut, and the tool nose radius are fixed, use these values to see what T-land width should be used.

Example 2: If you want to use a specific T-land width or hone only edge, use the chart below to see what maximum feeds and depths of cut are recommended for different nose radii.

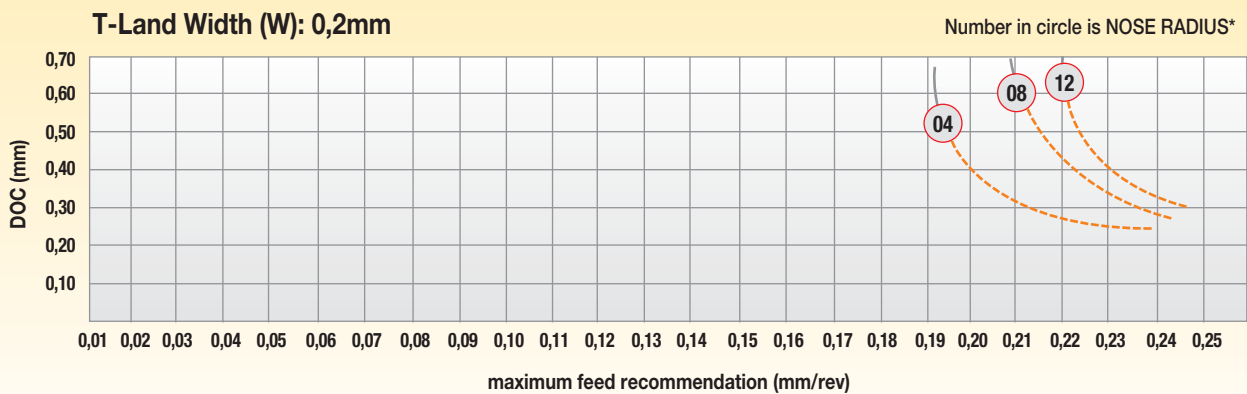
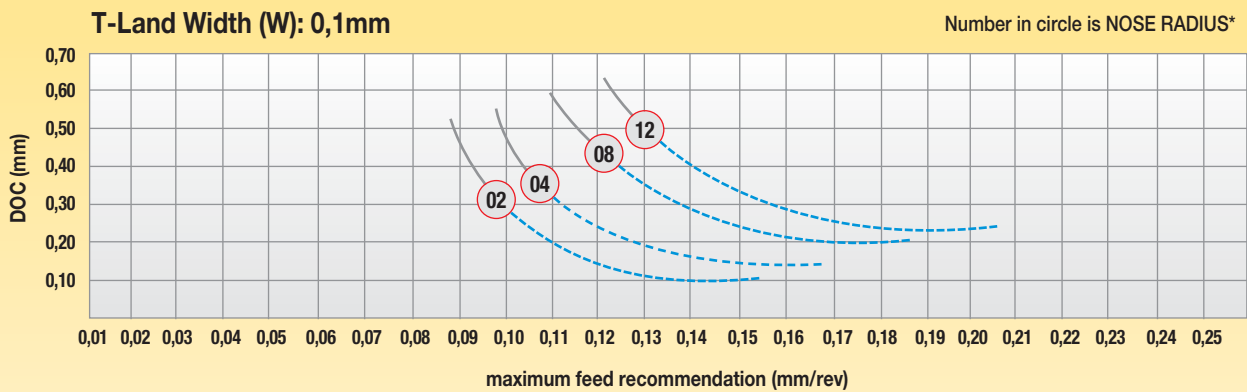
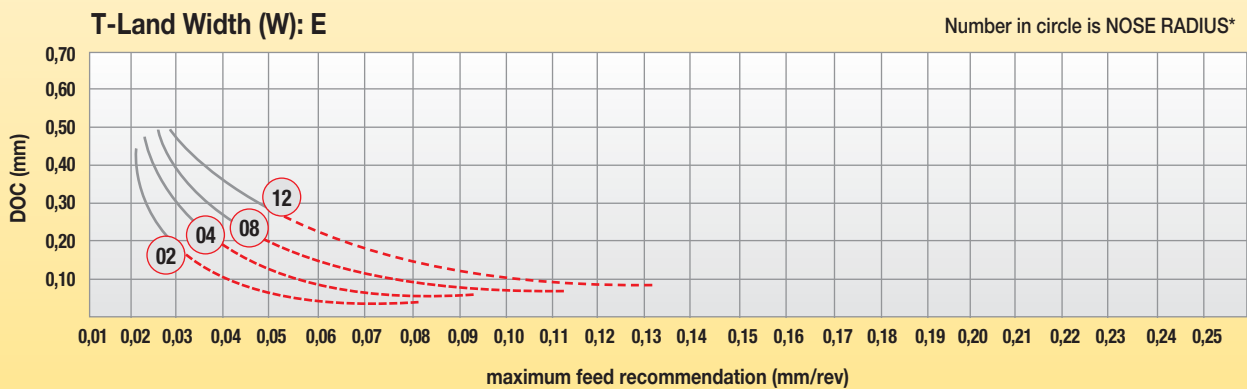
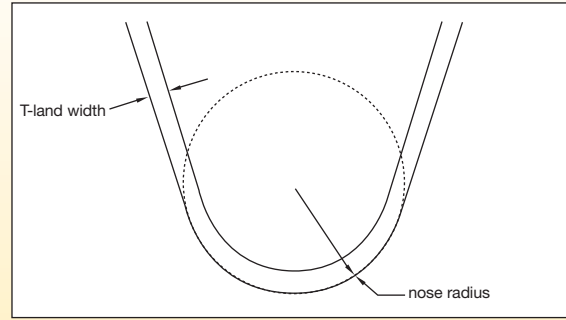

*NOTE: Colored lines represent proven solutions; grey lines represent theoretically possible solutions.

Step 5 • Choosing the speed range

How to Use

Using the application information, determine your position in the INPUT DATA table below and select the speed range area with which it intersects for each input parameter. If different speed ranges result, choose the lowest speed range.

The shaded area extends to the minimum and maximum speeds for the application. The suggested starting speeds can be taken as the minimum line of this range.

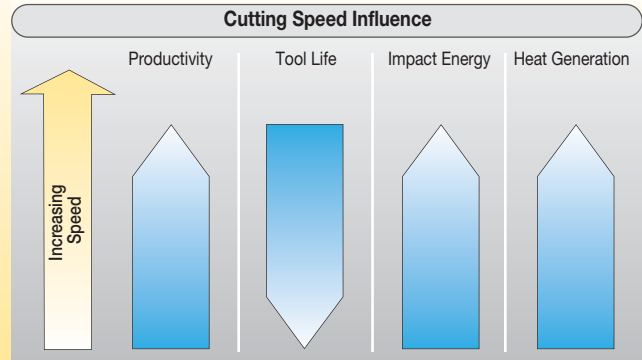

PCBN/PCD Inserts

Speed Range Selection for Hard Turning

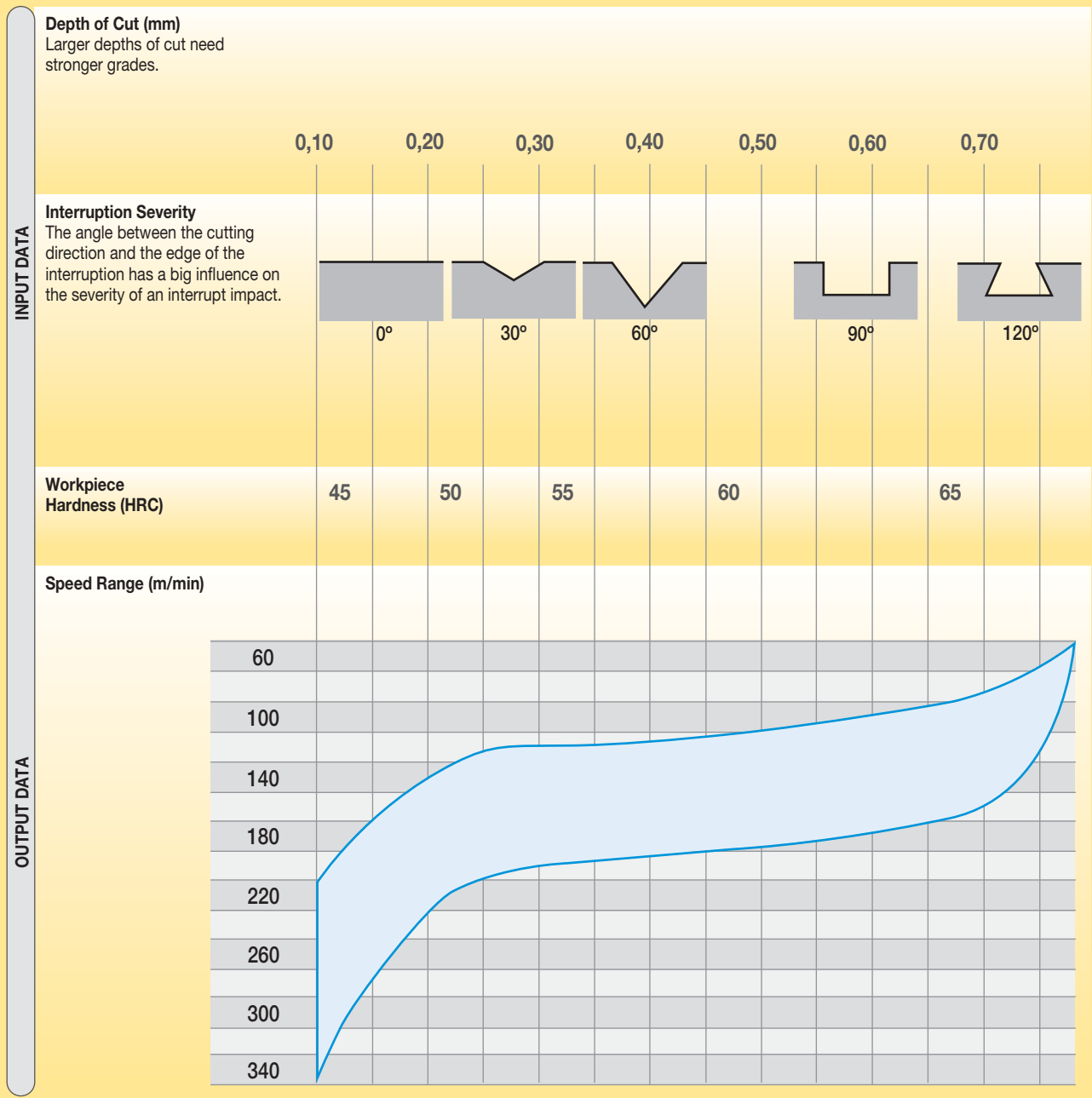



CBN Inserts with Chipbreaker

For hardened steels, grinding is no longer the preferred method in finish turning operations because hard turning now drastically reduces cost per part. With high metal removal rates, faster machine setup, quicker cycle times, and greater flexibility, it is obviously the preferred method.

Despite these advantages, hard turning has sometimes had issues with poor chip control causing surface scratching and bird-nest formations. Kennametal solved these problems by integrating special chipbreaking geometries into two high-performance PCBN grades, giving customers total control of their hard machining.

Ideally, hardened steels are machined with a low or medium CBN content grade where the workpiece encounters few interruptions. However, because of CBN's structure, the industry had not been able to add chipbreaking technology to low content CBN inserts. KB5610™ with chipbreaker is, therefore, the first product of its type to deliver chipbreaking where it's most needed. KB5625™ with chipbreaker provides a chipbreaking solution for applications requiring more toughness.

Together, these tools give Kennametal customers industry-leading flexibility in choosing the right tool for the job.

Features

- Chipbreaker for improved chip control.
- KB5610 ideal grade for continuous operations.
- KB5625 ideal grade for continuous and interrupted operations.

Benefits

- Improved surface quality to reduce scrap rates.
- Reduction of machine stops due to swarf issues to improve machine availability.
- Reduction of bird-nest formation to reduce clean up time.
- Two grades to choose from for best performance.

KB5610

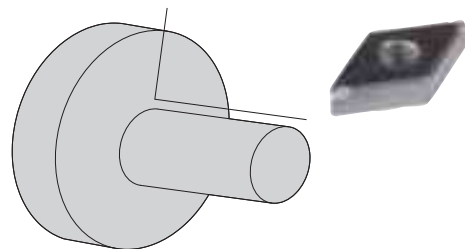

KB5625

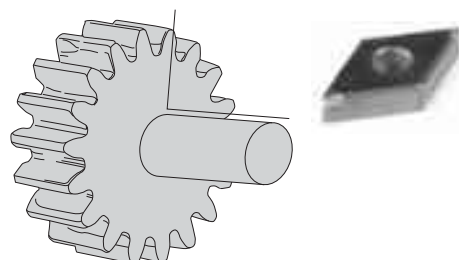

CBN Inserts

Insert without Chipbreaker



- Long chips.
- Bird-nest formation.

Insert with Chipbreaker



- Chips are broken.

■ Reverse gear face turning and chamfering

Workpiece: Reverse gear
Hardness: 58–62 HRC

	Competitor	Kennametal
Insert:	DNGG150412N-SV	DNGM159412S0125MT CB1
Grade:	—	KB5625
vc:	235 m/min (775 SFM)	235 m/min (775 SFM)
f:	0,25 mm/rev (.0098 in/rev)	0,35 mm/rev (.014 in/rev)
ap:	0,26mm (.0098")	0,26mm (.0098")
Pieces/edge:	600	900
Chip shape:	Snarling or infinite helix	Coiled with 3 turns

Result: Better chip control, high productivity (by increased feed), and 1,5x tool life

■ Hard material turning by using PCBN with chipbreaker

Workpiece: Tube
Hardness: 52–58 HRC

	Competitor	Kennametal
Insert:	DNGA150608S01020MT	DNGM150408S01325M7CB1
Grade:	—	KB5625
vc:	120 m/min (400 SFM)	120 m/min (400 SFM)
f:	0,15 mm/rev (.0059 in/rev)	0,15 mm/rev (.0059 in/rev)
ap:	0,3mm (.012")	0,3mm (.012")
Pieces/edge:	2	4
Chip shape:	Snarling or infinite helix	Discontinuous

Result: Better chip control and double tool life

■ PCBN portfolio

Grade	KB5630 (KB1630)	KB1340	Grade	
CBN%	90	90	CBN%	
<div style="background-color: red; color: white; padding: 10px; display: inline-block; font-size: 2em; font-weight: bold;">K</div> grey and hard cast irons	GG fine boring		KB1340 provides excellent toughness behaviour for rough machining of cast irons. Abrasion resistance of KB1630 for chilled, hardened irons.	
	K01			
	K30			

■ High content PCBN grades: KB1340™, KB1630™, and KB5630™

General Application Area

Continuous and interrupted machining of ferrous alloys where the main wear mode is abrasive and a strong edge is required.

Primary Target Workpiece Materials

- Grey cast irons.
- High Cr content irons.
- Chilled and hardened irons.
- Co-, Ni-, and Fe-based hard facing alloys.
- Other alloys in which there is a high concentration of carbide forming elements, and the primary wear is abrasive.



■ Machining grey cast iron

The largest application area for KB1340™ is machining of grey cast irons. Following are a few particulars of this application:

- GCI have to be machined dry. The application needs to generate high levels of heat in order to create a protective oxide layer on the tool.
- It is important to confirm with the customer that the GCI has been properly aged, and it has a sulphur content over 0,05%.
- The starting point for edge preparation should be 0,10mm (.004") x 20° for finishing (DOC <0,5mm) and 0,20mm (.008") x 20° for roughing.
- The edge preparation angle should increase if any interruptions are present, up to 35°.
- Lack of aging and/or low sulphur content can lead to a decrease in tool life of up to 10 times!
- A slow feed approach/engagement of the tool is recommended to minimise chipping and notching.



Proper application of KB1340 – formation of protective layer, tool life should exceed 70 km sliding distance.

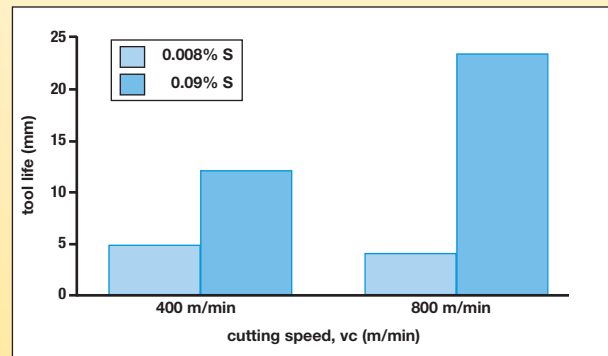

Comparison of the life of PCBN cutting tools in machining two different grey cast irons, primarily differing in sulphur content.

■ Application recommendations

workpiece material	speed				feed				depth of cut			
	m/min		SFM		mm		in		mm		in	
	min	max	min	max	min	max	min	max	min	max	min	max
hot-work tool steels – roughing	50	150	165	495	0,2	0,5	0,008	0,020	0,8	3,0	0,031	0,118
cold-work tool steels – roughing	50	150	165	495	0,2	0,5	0,008	0,020	0,8	3,0	0,031	0,118
grey cast iron – roughing	700	1200	2310	3960	0,2	0,6	0,008	0,024	0,5	3,0	0,020	0,118
grey cast iron – finishing	750	1500	2475	4950	0,1	0,3	0,004	0,012	–	0,5	0,000	0,020
CGI and NCI – roughing	50	300	165	990	0,2	0,5	0,008	0,020	0,5	2,0	0,020	0,079
chilled cast iron – roughing	30	150	99	495	0,2	0,6	0,008	0,024	0,5	3,0	0,020	0,118
chilled cast iron – finishing	30	150	99	495	0,1	0,3	0,004	0,012	–	0,5	0,000	0,020
hard facings – as per bearing steel	60	200	198	660	0,1	0,5	0,004	0,020	0,2	3,0	0,008	0,118
high Cr irons	80	250	264	825	0,1	0,6	0,004	0,024	0,2	3,0	0,008	0,118

High-content PCBN grades are intended for use in negative rake clamp-type toolholders, boring, recessing tools, and milling heads. Due to the dynamic loads that occur in the machining of hard ferrous materials and the conditions under which these grades operate, frequently involving shocks from interrupted cutting, it is advisable to strengthen the tool system as much as possible and use dimpled inserts where possible.



Dimple Clamps for Added Stability

Typical Application

Continuous cost pressures force manufacturers of grey cast iron brake disks to look for cost-cutting solutions. CBN inserts deliver high productivity and long tool life. Kennametal has developed the solid, high-content grade KB1340™, which provides superior performance when machining grey cast iron components, such as brake disks or fly wheels. To ensure secure seating in the toolholder, the inserts are available with dimple-design clamping. The clamps fit Ceramtec holders, which makes the conversion to Kennametal tooling easier.

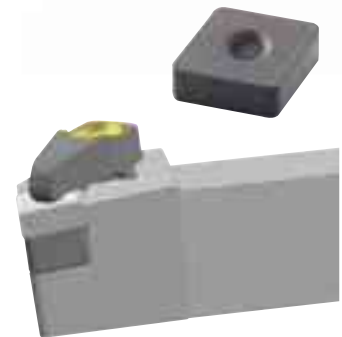

Higher Productivity and Profitability

- Ensures tight and rigid clamping.
- Dimpled insert with special clamping provides increased stability in the pocket.
- Ideal for use in heavy-duty machining applications.
- Cladded clamps for improved resistance against chip wash are available upon request.
- The shallow dimple design enables the use of less expensive 4,76mm (3/16") inserts.
- Round dimple design works with custom tooling where clamping direction must be offset due to space limitations.

Featured Applications: Brake Disk Machining

■ Proven solutions

Workpiece: Brake disk
Material: GGG 60



	Competitor CBN	Kennametal KB1340
Insert:	N/A	SNMN120416502020
vc:	1100 m/min (3600 SFM)	1100 m/min (3600 SFM)
f:	0,4 mm/rev (.016 in/rev)	0,4 mm/rev (.016 in/rev)
ap:	2mm (.079")	2mm (.079")
Performance:	1500 pieces	1700 pieces

	Competitor Ceramic	Kennametal CBN KB1340
Insert:	N/A	CNGX433S0415FW
vc:	800 m/min (2600 SFM)	1500 m/min (5000 SFM)
f:	0,5 mm/rev (.02 in/rev)	0,5 mm/rev (.02 in/rev)
ap:	1,5mm (.059")	1,5mm (.059")
Performance:	120 pieces	4200 pieces

■ Clamp selection chart

insert		clamp	
ANSI catalogue number	ISO catalogue number	catalogue number	MM
CNGX433S0415	CNGX120412S01015	551.718 - 100° Corner	3968904
CNGX433S0415FW	CNGX120412S01015FW	551.718 - 100° Corner	3968904
CNGX434S0820	CNGX120416S02020	551.718 - 100° Corner	3968904
CNGF432	CNGF120408	551.718 - 100° Corner	3968904
DNGX434S0820	DNGX150416S02020	551.720	4094234
SNGX434S0820	SNGX120416S02020	551.718	3968904
SNGX534S0820	SNGX150416S02020	551.718	3968904
VNGX333S0820	VNGX160412S02020	551.721	4094236
TNGX333EFW	TNGX160412EFW	551.733	4094235

■ Application recommendation

vc: 800–1500 m/min

Certain melts of grey cast iron can exhibit poor machinability — by as much as two orders of magnitude — **related to either insufficient aging or composition.**



Good GG25 (0.05 S)
62 km sliding distance @ 1500 m/min

■ Grey cast iron brake disk machining • Ceramic vs. PCBN



(a)

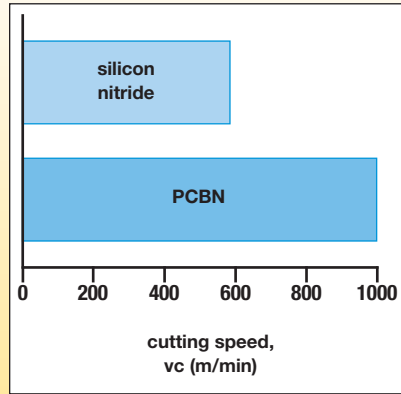

(b)

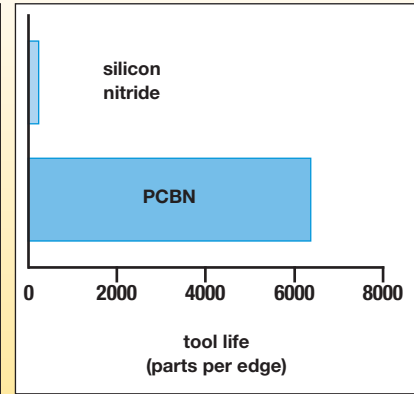

(c)

PCBN increases productivity when machining grey iron brake disks (a) in terms of cutting speed (b) and tool life (c) compared to silicon nitride ceramic.

■ Brake disk machining example



Optimised Process

Tool Material: PCBN

Tool Life: 2000 brake disks

Starting Situation

Tool Material: black ceramic

Tool Life: 40 brake disks

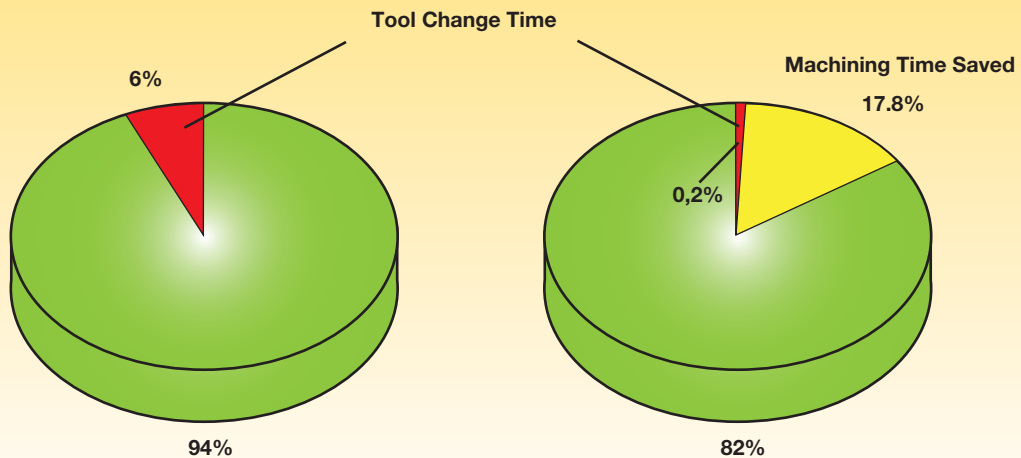

■ PCBN portfolio

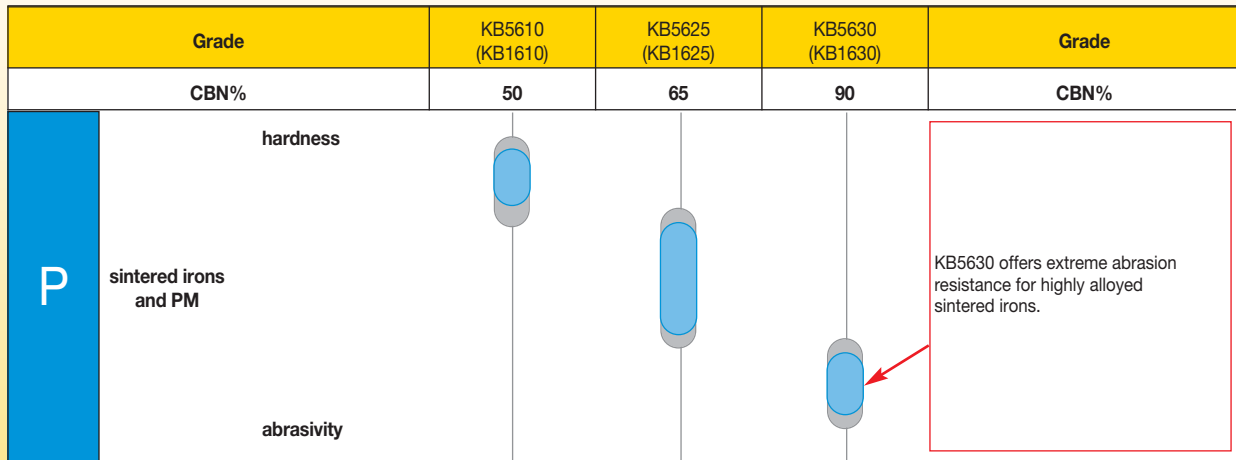

PCBN/PCD Inserts

■ PM machining • Inlet/outlet valve

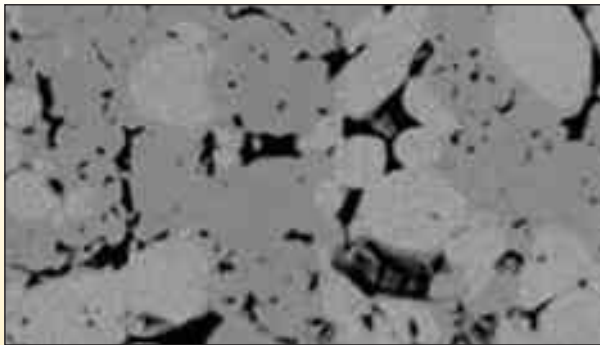

50 μm



50 μm

Exhaust

- Abrasive with hard particle content:
 - Martensite – 800 HK
 - WMoC – 1600 HK
 - VC – 2800 HK
- High porosity/Cu infiltrated.
- Co increases hot hardness.
- Macro-hardness <400 HV (<41 HRC).
- Derives wear resistance from hard particles.



Intake

- Principally, structure is hard steel.
- Minimal porosity on well sintered.
- Low/medium alloy content.
- Macro-hardness >400 HV (>41 HRC).
- Derives wear resistance from hardened matrix structure.

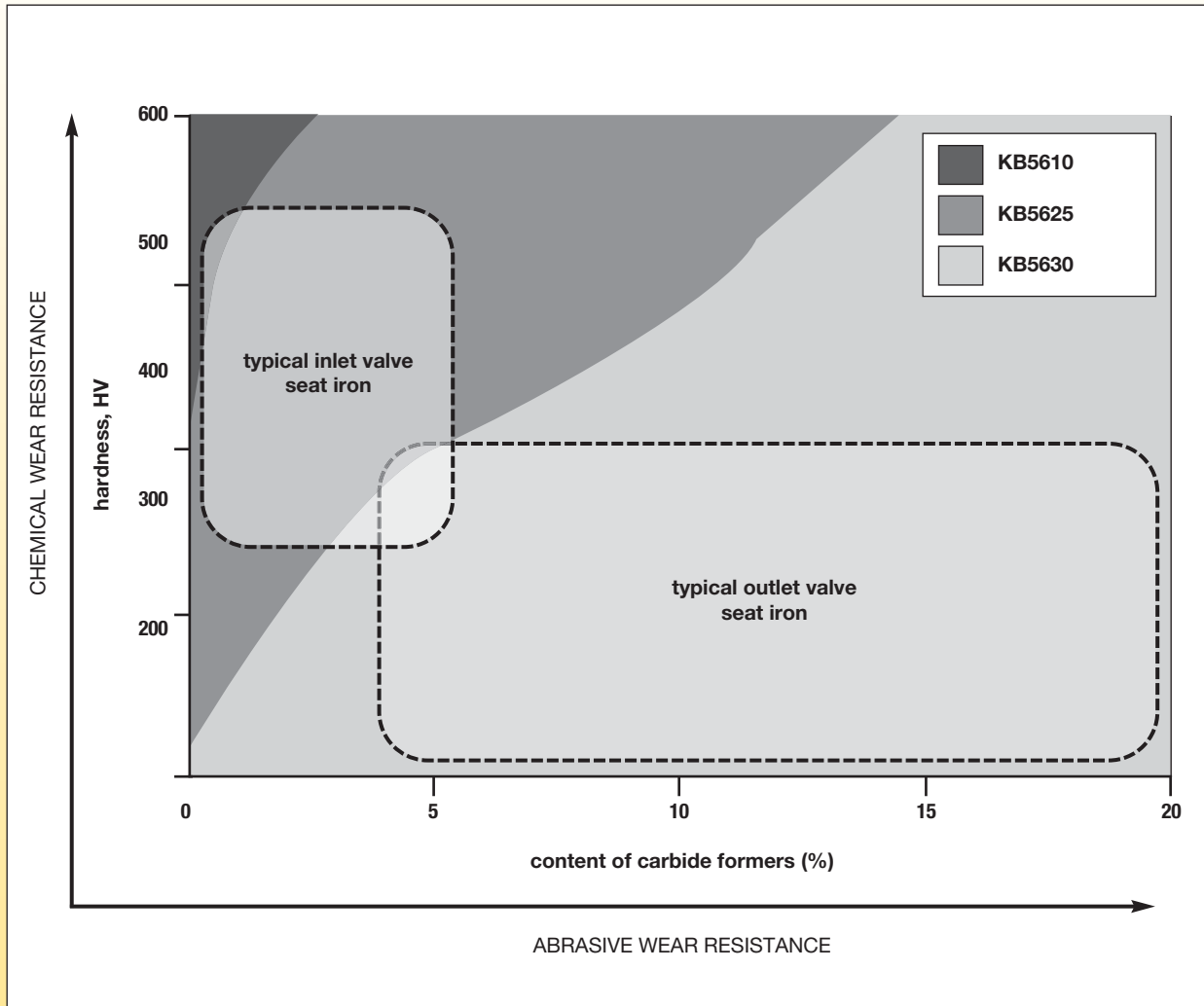
■ PCBN grade selection for valve seat machining

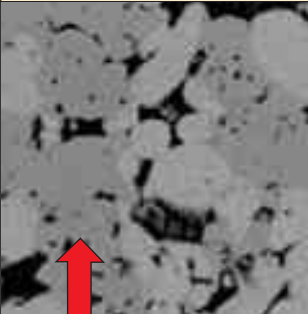

■ PCBN grade selection for valve seat machining

	material to be machined	short engagement (e.g., plunging)	long engagement (e.g., generating)
	Soft matrix (≤ 300 HV), hard carbides, high porosity	1. Abrasion resistance 2. Strength #1 Choice: KB5630™	1. Abrasion resistance 2. Strength 3. Chemical wear resistance #1 Choice: KB5630
<p>Highly Abrasive</p> <p>High Hardness</p>	Both material types with single insert	1. Abrasion resistance 2. Chemical wear resistance 3. Strength #1 Choice: KB5630 #2 Choice: KB5625™	1. Abrasion and chemical wear resistance 2. Strength #1 Choice: KB5625 #2 Choice: KB5630
	Hard matrix (≥ 400 HV), few carbides, low porosity	1. Chemical wear resistance 2. Strength 3. Abrasion resistance #1 Choice: KB5625 #2 Choice: KB5610™	1. Chemical wear resistance 2. Abrasion resistance 3. Strength #1 Choice: KB5625 #2 Choice: KB5610



PCBN/PCD Inserts



A4™ Grooving and Turning System

- One tool for turning, facing, grooving, and face grooving in O.D. and I.D. applications — that means exceptionally fast cycle times and no turret indexes.
- Extra-long clamping area, ground 120° bottom prism seating surface, and an exclusive top guide rail combine to deliver unsurpassed grooving and side-turning stability!
- Precise insert positioning is ensured for accurate cuts!

Clamping Design



Applications

■ Test result • A4

Tool: A4R0400M04800E KB1630
Material: INCONEL® 718
Diameter: 983mm

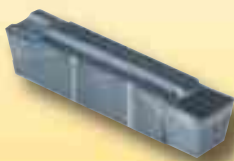

Cutting Data	Competitor	Kennametal
Speed:	180 m/min (600 SFM)	180 m/min (600 SFM)
Feed:	0,13mm/rev (.0051 in/rev)	0,13mm/rev (.0051 in/rev)
DOC:	8mm (.31")	8mm (.31")
Diameter:	30mm (1.18")	30mm (1.18")
Performance:	70–140 pieces	160–200 pieces



Top Notch™ Grooving System

Our rigid clamping design prevents insert movement. This benefit ensures excellent surface finish, improved productivity, and superior tool life and promotes perfect concentricity. The rugged bridge clamp generates locking forces in three directions to provide superior resistance to side thrust and tangential forces.

Clamping Design



Applications

■ Test result • Top Notch

Tool: WSP 4121129 Top Notch KB5625
Material: DIN 16MnCr5/AISI 5115, 59–63 HRC
Machine: Hard/soft machining



Cutting Data	Competitor	Kennametal
Speed:	160 m/min (530 SFM)	160 m/min (530 SFM)
Feed:	0,06 mm/rev (.0024 in/rev)	0,06 mm/rev (.0024 in/rev)
DOC:	2mm (.079")	2mm (.079")
Diameter:	39,5mm (1.56")	39,5mm (1.56")
Performance:	70 pieces	90 pieces

Quick Optimisation Guide: Troubleshooting for Catastrophic Failure

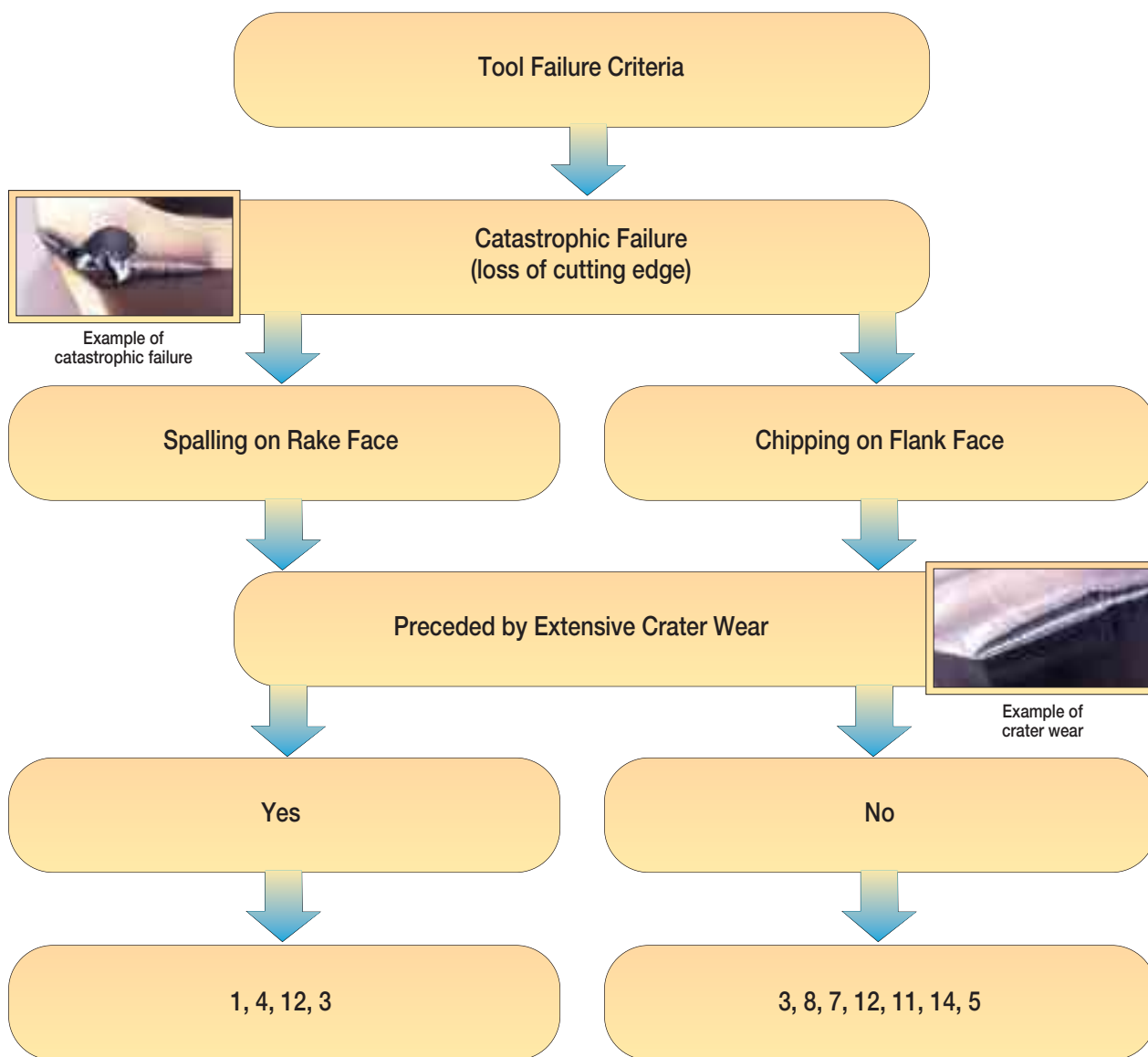

Remedial Action

- | | |
|---------------------------------------------------------------------------------------------------------------------------------------------------------------------------------------------------------------------------------------------------------------------------------------------------------------------------------------------------------------|--------------------------------------------------------------------------------------------------------------------------------------------------------------------------------------------------------------------------------------------------------------------------------------------------------------------------------------------|
| <ol style="list-style-type: none"> 1. Select more inert PCBN grade. 2. Select more abrasion-resistant PCBN grade. 3. Select stronger PCBN grade. 4. Reduce cutting speed. 5. Increase cutting speed. 6. Reduce nose radius. 7. Increase nose radius. 8. Increase chamfer angle. | <ol style="list-style-type: none"> 9. Decrease chamfer angle. 10. Increase clearance angle. 11. Reduce clearance angle. 12. Increase edge hone dimension. 13. Reduce edge hone dimension. 14. Reduce feed and/or depth of cut. 15. Increase feed and/or depth of cut. |
|---------------------------------------------------------------------------------------------------------------------------------------------------------------------------------------------------------------------------------------------------------------------------------------------------------------------------------------------------------------|--------------------------------------------------------------------------------------------------------------------------------------------------------------------------------------------------------------------------------------------------------------------------------------------------------------------------------------------|

Quick Optimisation Guide: Troubleshooting for Non-Catastrophic Failure

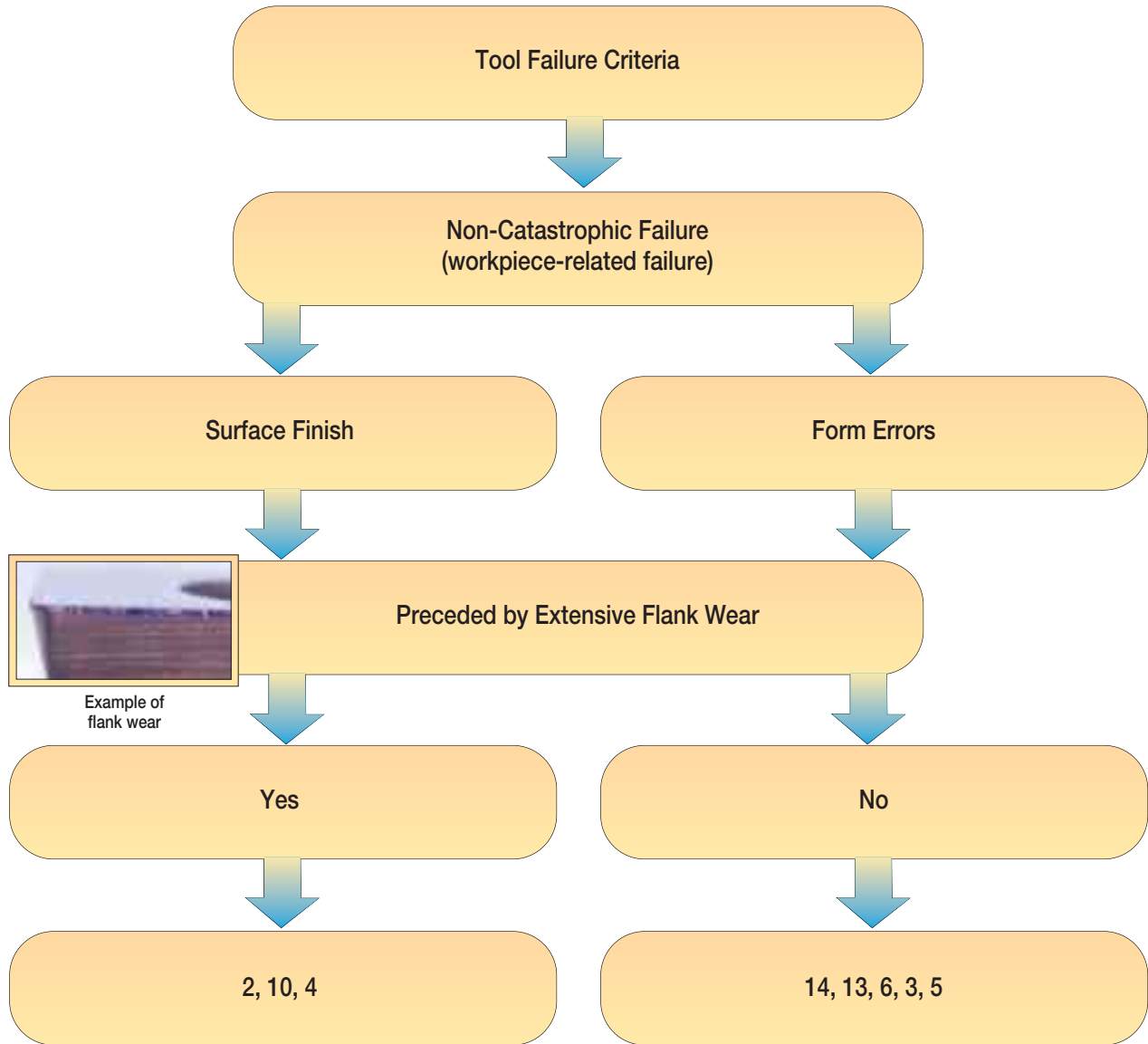

Remedial Action

- | | |
|---------------------------------------------------------------------------------------------------------------------------------------------------------------------------------------------------------------------------------------------------------------------------------------------------------------------------------------------------------------|--------------------------------------------------------------------------------------------------------------------------------------------------------------------------------------------------------------------------------------------------------------------------------------------------------------------------------------------|
| <ol style="list-style-type: none"> 1. Select more inert PCBN grade. 2. Select more abrasion-resistant PCBN grade. 3. Select stronger PCBN grade. 4. Reduce cutting speed. 5. Increase cutting speed. 6. Reduce nose radius. 7. Increase nose radius. 8. Increase chamfer angle. | <ol style="list-style-type: none"> 9. Decrease chamfer angle. 10. Increase clearance angle. 11. Reduce clearance angle. 12. Increase edge hone dimension. 13. Reduce edge hone dimension. 14. Reduce feed and/or depth of cut. 15. Increase feed and/or depth of cut. |
|---------------------------------------------------------------------------------------------------------------------------------------------------------------------------------------------------------------------------------------------------------------------------------------------------------------------------------------------------------------|--------------------------------------------------------------------------------------------------------------------------------------------------------------------------------------------------------------------------------------------------------------------------------------------------------------------------------------------|



Quick-Turn Solutions Program for CBN Inserts

Standard inserts incorporate latest grade, coating, edge preparation, and manufacturing technology. They cover a wide range of applications and provide superior performance.

However, in some cases, further fine tuning is needed to reach the optimum performance point. Therefore, Kennametal has set up the Quick-Turn Solutions Program (QTSP) to allow edge preparation modifications on selected styles, grades, and formats to further enhance the tool performance.



Technical Details • Options for a Customisation

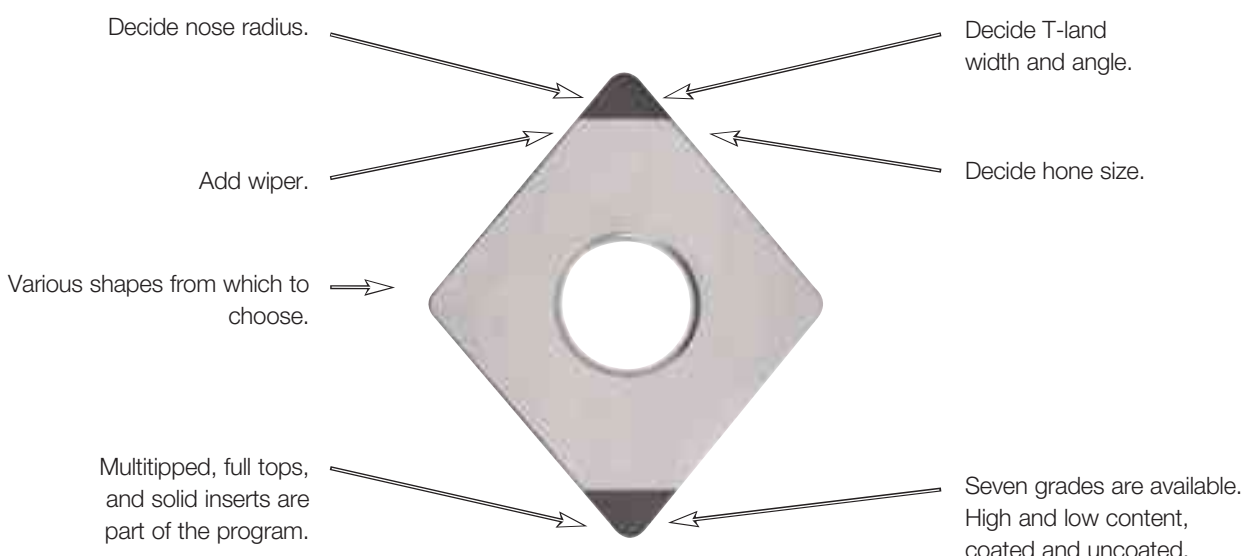

For more information, please contact a Kennametal Sales Representative, Authorised Kennametal Distributor, or visit www.kennametal.com.

Teardrop (TD Edges) for Demanding Applications

Teardrop (TD) edges are advanced edge preparations used in heavily interrupted operations where standard edge preps fail. They can be ordered as specials.

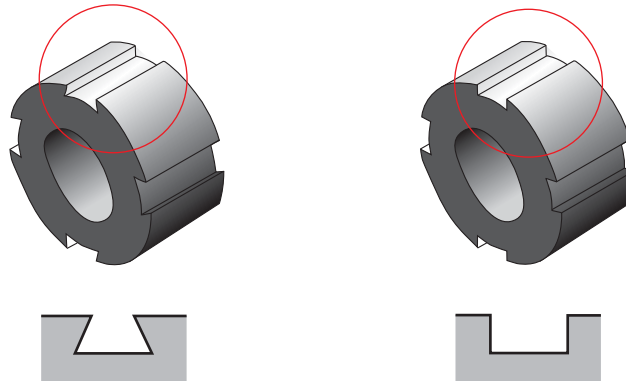

Possible TD Edges

- W – Edge Prep Width
- α – Clearance Angle
- β – Edge Prep Angle – between rake face and K-land

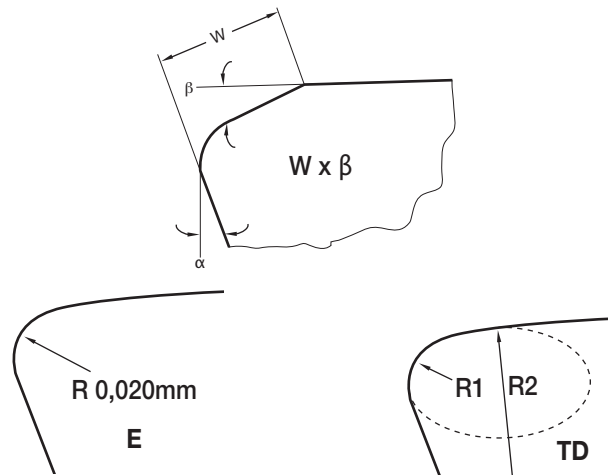

Edge Preparation Specifications			TD-Style Selection	
E	hone only	0,020mm		
W x β	width in 0,001mm x angle			
TDR	ellipse based on 0,25 x 30°			
TDF	ellipse based on 0,20 x 20°			
TDS	ellipse based on 0,10 x 20°			



■ PCD

The current global metalcutting climate has put increased focus on high productivity and cost reductions coming from cutting tools. These requirements lead to the rapid growth and implementation of cutting tools using superhard materials. As the name implies, these materials have a significant advantage in hardness over conventional tool materials, which from the end user point of view, translates into increased productivity (higher cutting speeds, longer tool life, etc.), lower tooling cost per part, and also, the ability to process materials previously un-machinable with conventional tooling.

The most widely known superhard materials are diamond and cubic boron nitride. Our industry uses the polycrystalline forms of these materials, i.e., polycrystalline diamond (PCD) and polycrystalline boron nitride (PCBN). PCD tooling is mainly targeted at the machining of non-ferrous materials (e.g., aluminium alloys, plastics, CFRPs, composites, titanium alloys, ceramics, carbides, etc.) whereas PCBN targets iron-based alloys (e.g., cast irons, hard steels, iron-based composites, etc.)

Kennametal is at the forefront of developing and implementing superhard materials in our standard and special tooling solutions across all our product lines. Kennametal's approach to superhard tooling starts with customer needs and constraints. We then use fundamental research to develop the best superhard solutions that would make available the best value for the customer and respond to their specific demands.

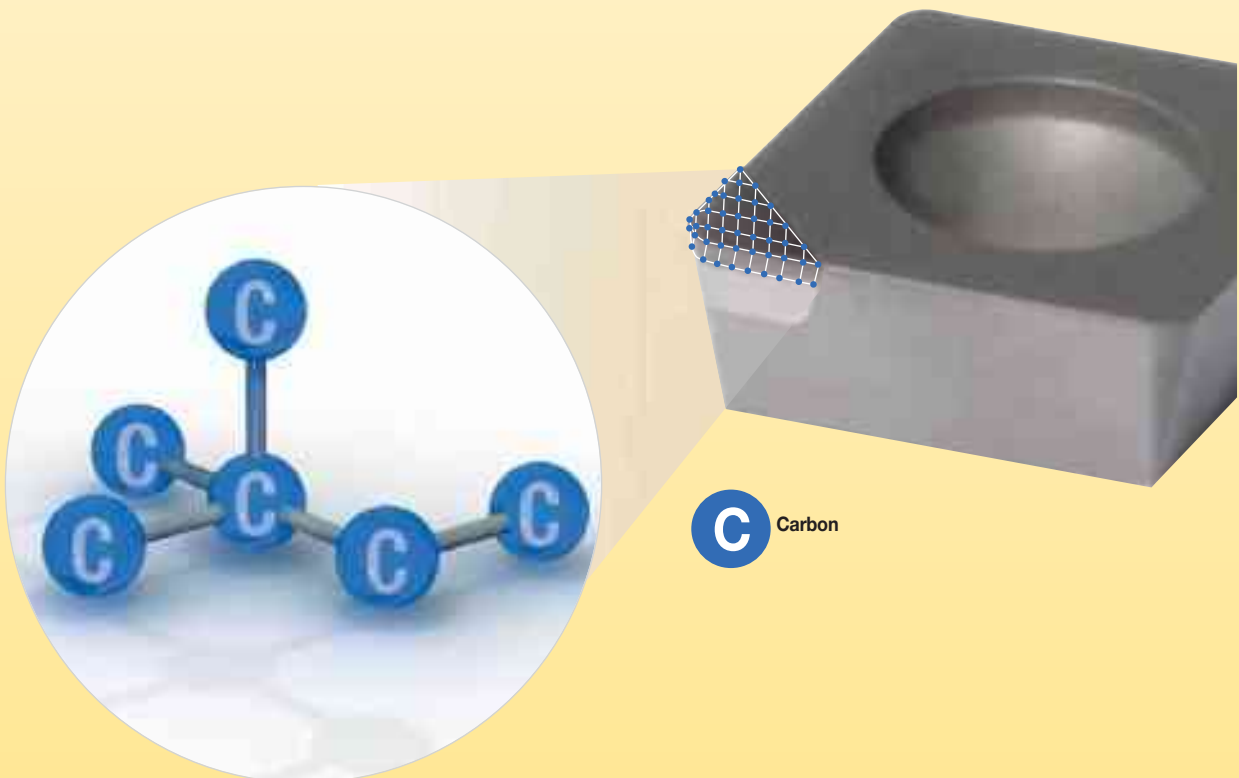

■ Different kinds of PCD grades

Application demands determine the choice of cutting tool material. The important requirements of the material are:

- Abrasion resistance.
- Toughness and strength.
- Thermal behaviour.



Fine Grain

Medium Grain

Coarse Grain

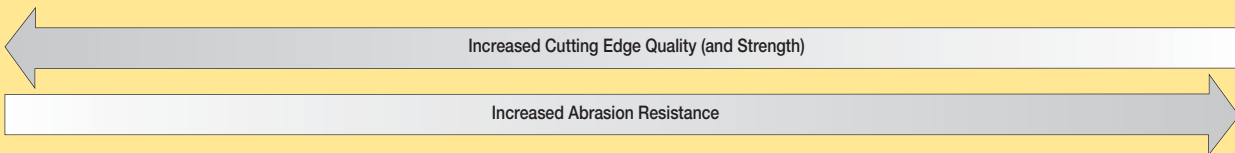

■ Comparison of different PCD grades

Behaviour in Applications

grade characteristics:	KD1400™	fine grain	medium grain
grain size:	0,5–1 μm	2 μm	10 μm
chip resistance:			
abrasion resistance:			

Behaviour in Applications

grade characteristics:	coarse grain	KD1425™	KD1405™
grain size:	25 μm	2–30 μm	0 μm
chip resistance:			
abrasion resistance:			

Chipping can be defined as the formation of small notches on the cutting edge and generally occurs when the load at the cutting edge exceeds the strength of the material. An A390 alloy was used in edge milling tests to assess the chip resistance of the different PCD grades.

Abrasion is characterised by the development of grooves and ridges on the flank of the tool in the direction of sliding. The abrasion resistance of PCD was evaluated on a high silicon aluminium alloy, A390, in a continuous cutting operation.

■ PCD grain size • Workpiece surface finish

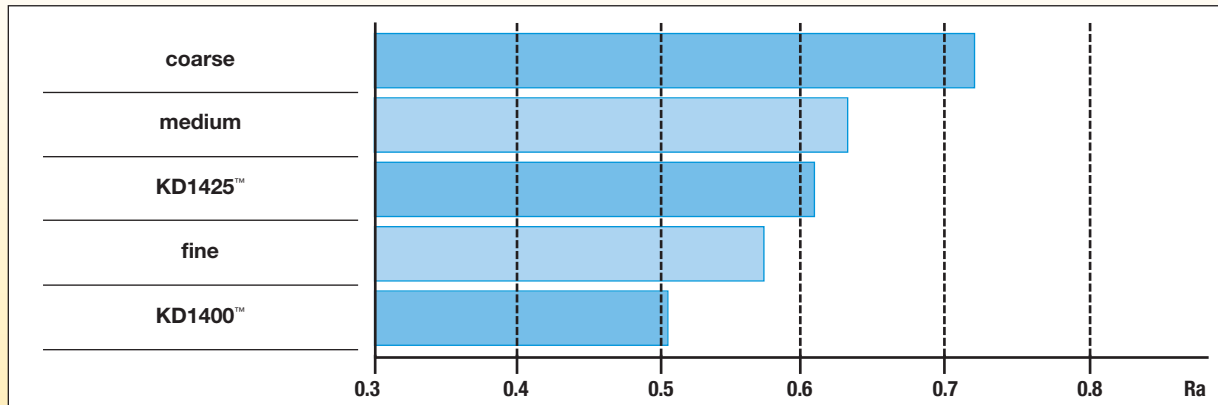

This chart illustrates the influence of the PCD grain size on surface finish in turning 18% silicon aluminium alloys. The best finish is obtained with the submicron grade KD1400. While the grade KD1425 contains grains as large as 30 microns, this material's unique multimodal grain size distribution results in a microstructure of closely packed diamond grains resulting in a smoother ground edge.

■ KD1400 advantages at a glance • Summary

A sharper cutting edge

- Clean cuts on carbon fibres.
- Permits larger nose radii for increased feed and productivity without loss in finish.

A less serrated (smoother) cutting edge

- Improved surface finish — potentially reducing rough and intermediate honing.

Permits a more positive rake

- Reduced cutting forces, delamination, and burr formation.

Permits increased clearance

- Providing for lower tool wear rates and lower push-off forces — thereby improving process capability.

Provides unparalleled chip resistance

- Suitable for heavy milling and interrupted turning with positive edge geometries and longest tool life.

Comparable abrasion resistance to a coarse grade PCD

- Covers the widest range of applications with a single grade — reduce inventory and complexity.

■ PCD grades application/workpiece material

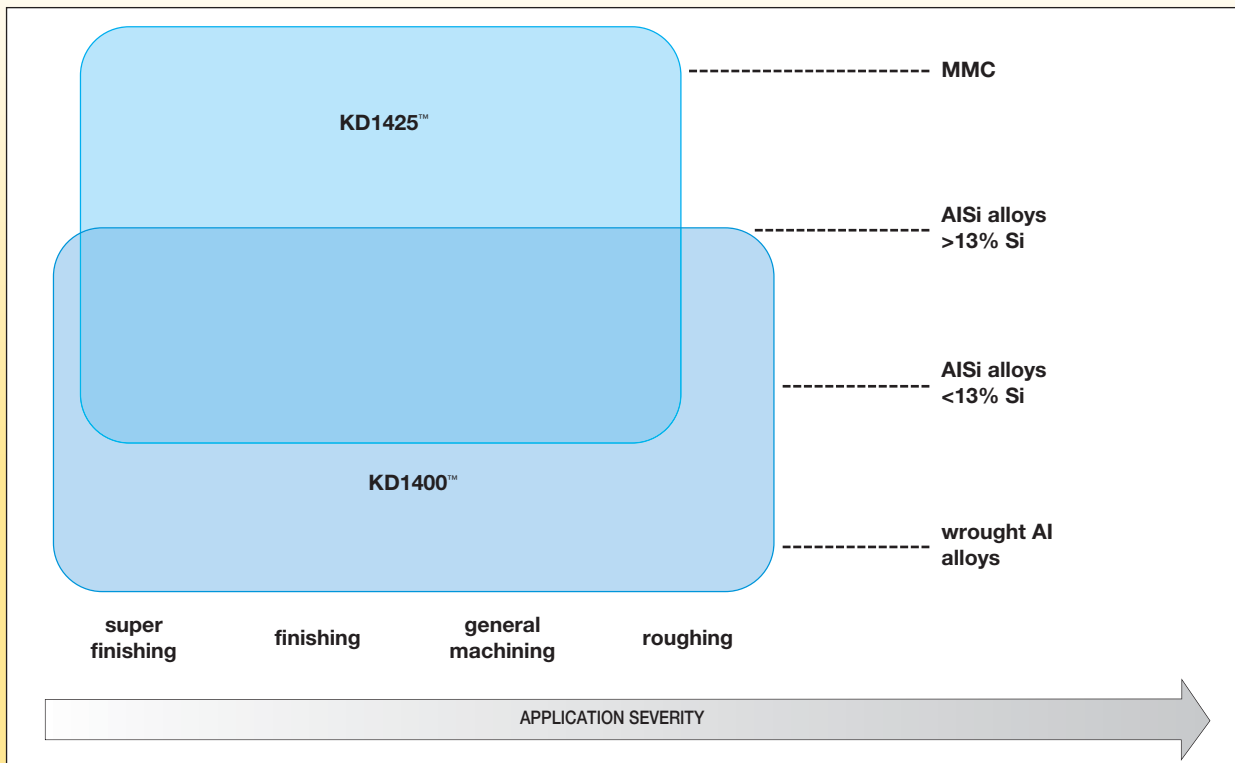

■ PCD application areas and parameter range

material machined	operation	PCD grade	speed				feed rate				DOC			
			m/min		SFM		mm/rev		in/rev		mm		in	
			min	max	min	max	min	max	min	max	min	max	min	max
aluminium alloy	turning	KD1400	1000	4000	3300	13200	0,1	0,4	0,004	0,016	0,1	4,0	0,004	0,157
4-8% Si	milling		2000	5000	6600	16500	0,1	0,3	0,004	0,012	0,1	0,3	0,004	0,012
9-12% Si	turning		700	3000	2310	9900	0,1	0,4	0,004	0,016	0,1	4,0	0,004	0,157
>13 Si	milling	KD1400/KD1425	1000	3000	3300	9900	0,1	0,3	0,004	0,012	0,1	0,3	0,004	0,012
	turning	KD1425	300	1000	990	3300	0,1	0,4	0,004	0,016	0,1	4,0	0,004	0,157
	milling	KD1400	500	1500	1650	4950	0,1	0,3	0,004	0,012	0,1	0,3	0,004	0,012
cast iron	roughing	KD1425	50	300	165	990	0,2	0,5	0,008	0,020	0,5	3,0	0,020	0,118
CGI/NCI	finishing		50	400	165	1320	0,1	0,3	0,004	0,012	—	0,5	—	0,020
MMC 20% SiC/Al	turning/milling		300	700	990	2310	0,1	0,4	0,004	0,016	0,2	1,5	0,008	0,059
copper alloys	turning/milling	KD1400	400	1300	1320	4290	0,03	0,3	0,001	0,012	0,05	2,0	0,002	0,079
copper, zinc, brass														
tungsten carbide <16% Co	turning	KD1425	30	120	99	396	0,1	0,4	0,004	0,016	0,2	1,0	0,008	0,039
unsintered (green)			20	60	66	198	0,1	0,25	0,004	0,010	0,1	0,5	0,004	0,020
sintered	—	—	—	—	—	—	—	—	—	—	—	—	—	—
ceramics	turning	KD1425	70	120	231	396	0,1	0,4	0,004	0,016	0,2	1,0	0,008	0,039
unsintered			50	100	165	330	0,1	0,25	0,004	0,010	0,1	0,5	0,004	0,020
sintered	—	—	—	—	—	—	—	—	—	—	—	—	—	—
plastics/composites	turning/milling	KD1400/KD1425	300	990	990	8250	0,05	0,3	0,002	0,012	0,2	3,0	0,004	0,118
carbon/graphite			200	660	660	3300	0,05	0,5	0,002	0,020	0,1	3,0	0,004	0,118

■ PCD tool failure modes

The gradual wear observed on diamond cutting tools can be divided into:

- Mechanically activated wear (abrasion, adhesion, and wear by microfracture).
- Tribochemical wear (dissolution/diffusion wear and formation of new chemical compounds).

Abrasion

The primary mode of mechanically activated wear for diamond cutting tools is abrasion, which is the removal of tool material by a scoring action of protruding asperities and hard phase inclusions in the workpiece and chip (e.g., silicon grains in aluminium-silicon alloys).

Abrasion is characterised by the development of grooves and ridges in the direction of the tool sliding against a newly machined surface of the workpiece or chip sliding against the rake face.

The severity of abrasion can be increased in cases where the workpiece material contains hard inclusions or when there is hard wear debris from the workpiece or the tool at the interface.

Tribochemical

Tribochemical wear is particularly relevant in the machining of titanium alloys when the carbon in the tool material diffuses into the adhered titanium layer to form a TiC boundary layer on the rake face of the tool.

This boundary quickly becomes saturated with tool constituents and can then act as a protective barrier against any further diffusion.

Attrition

When two surfaces slide over each other, particularly in the absence of a lubricant, some adhesion can occur at the points of contact. Adhesive wear (often called attrition) in cutting tools involves the mechanism in which individual grains or small grain aggregates are pulled out of the tool surfaces and are carried away at the underside of the chip or are torn away by the adherent workpiece. The term “plucking” is also used to describe the loss of tool particles from the edge or faces. For example, when the forces are high enough, the TiC boundary layer that forms in titanium machining can be removed from the rake face of the tool transporting with it a pulled-out diamond grain, to form a crater. Once this crater becomes excessive, fracture of the tool could occur due to the geometrical weakening of the edge. Negative geometries tend to enhance the possibility of adhesive wear and built-up edge formation. Subsequent break-up (fracture) of the adhesive tool/workpiece joints results in attrition wear. The wear scars produced by attrition are rough, as opposed to the usually smooth wear surfaces generated by tribochemical wear.

Microfracture

When cutting tools are employed for continuous machining of high hardness materials or interrupted machining, small fractures can appear on the cutting edge. If fracturing is small, the cutting tool can usually still be used. Wear by microfracture involves a less severe form of fracture and includes chipping, spalling, and cracking whereby the cutting tool can be reused.

Tool Failure and Wear:

PCBN/PCD Inserts

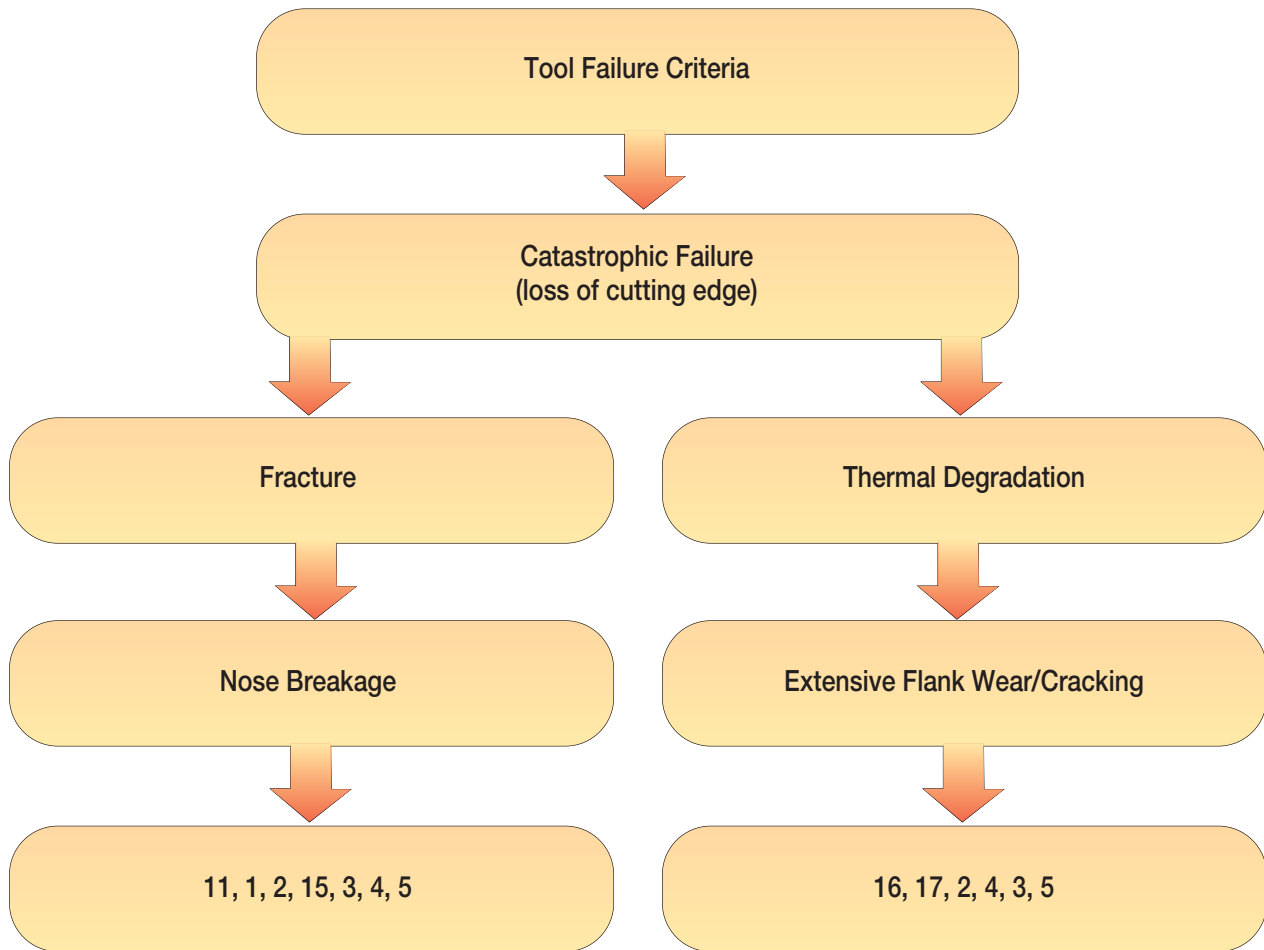

Remedial Action

- | | |
|--------------------------------------------------------------------------------------------------------------------------------------------------------------------------------------------------------------------------------------------------------------------------------------------------------------------------------------------------------|-----------------------------------------------------------------------------------------------------------------------------------------------------------------------------------------------------------------------------------------------------------------------------------------------------------------------------------------------------------------------------|
| <ol style="list-style-type: none"> 1. Increase nose radius. 2. Reduced clearance angle. 3. Reduce feed. 4. Reduce cutting speed. 5. Reduce DOC. 6. Increase clearance angle. 7. Use a positive rake angle. 8. Add a small edge hone. 9. Use neutral rake angle. | <ol style="list-style-type: none"> 10. Increase lead angle. 11. Select a tougher grade. 12. Select more abrasion-resistant grade. 13. Select a higher TRS grade. 14. Choose a more chemically inert grade. 15. Increase thickness. 16. Select a more thermally stable grade. 17. Use coolant. |
|--------------------------------------------------------------------------------------------------------------------------------------------------------------------------------------------------------------------------------------------------------------------------------------------------------------------------------------------------------|-----------------------------------------------------------------------------------------------------------------------------------------------------------------------------------------------------------------------------------------------------------------------------------------------------------------------------------------------------------------------------|

Tool Failure and Wear:

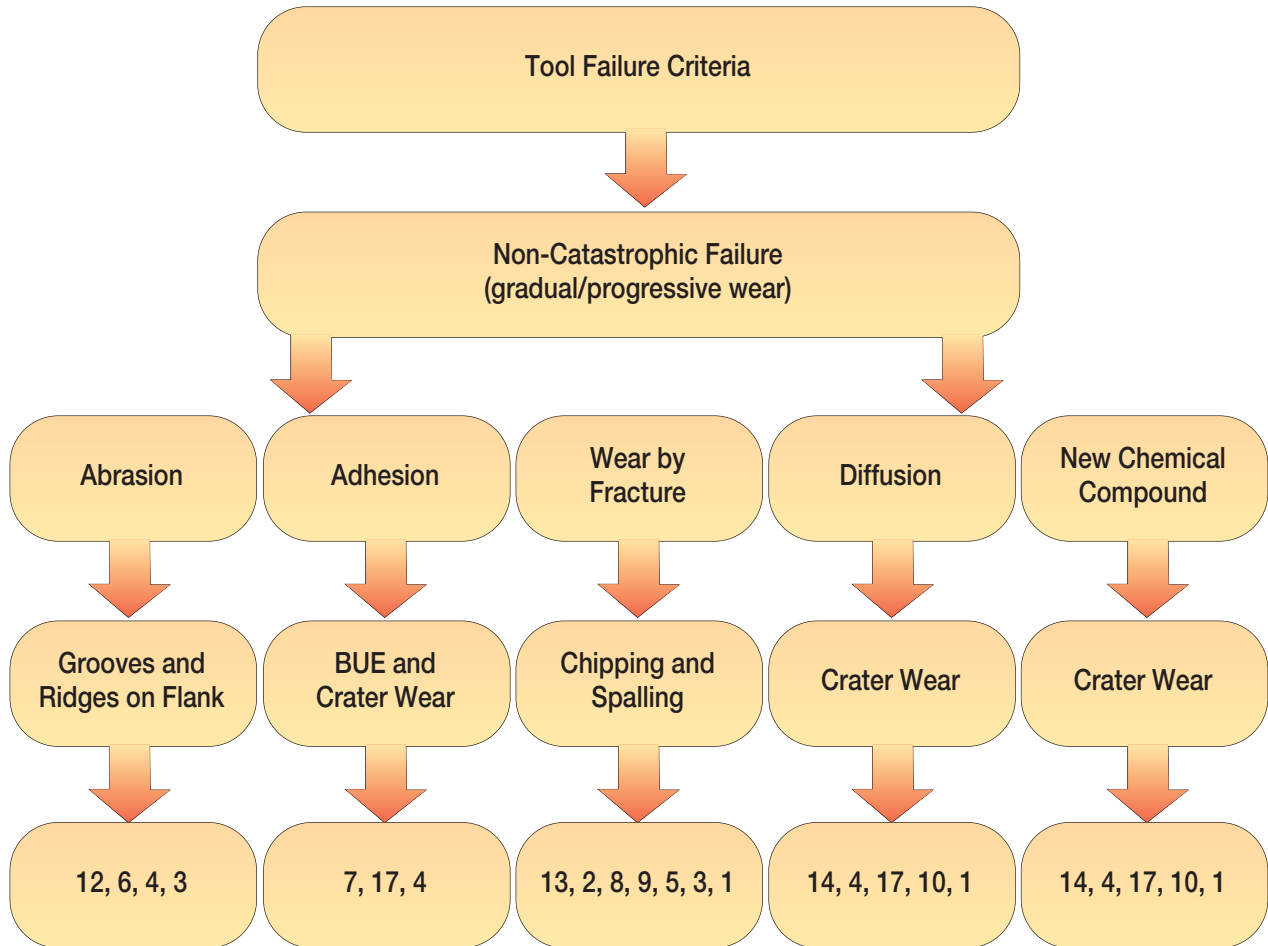

Remedial Action

1. Increase nose radius.
2. Reduced clearance angle.
3. Reduce feed.
4. Reduce cutting speed.
5. Reduce DOC.
6. Increase clearance angle.
7. Use a positive rake angle.
8. Add a small edge hone.
9. Use neutral rake angle.
10. Increase lead angle.
11. Select a tougher grade.
12. Select more abrasion-resistant grade.
13. Select a higher TRS grade.
14. Choose a more chemically inert grade.
15. Increase thickness.
16. Select a more thermally stable grade.
17. Use coolant.

■ Machining of carbides with superhards

material machined	operation	PCD grade	speed				feed rate				DOC			
			m/min		SFM		mm/rev		in/rev		mm		in	
			min	max	min	max	min	max	min	max	min	max	min	max
tungsten carbide <19% Co														
unsintered (green)	turning	KD1425	30	120	99	396	0,1	0,4	0,004	0,016	0,2	1,0	0,008	0,039
sintered	turning	KD1425	20	80	66	264	0,1	0,25	0,004	0,010	0,1	0,5	0,004	0,020
tungsten carbide >19% Co														
unsintered (green)	turning	KB1340	50	150	165	495	0,1	0,5	0,004	0,020	0,2	1,0	0,008	0,039
sintered	turning	KB1340	30	100	99	330	0,1	0,4	0,004	0,016	0,1	0,5	0,004	0,020

Application Notes

- PCD tools should be used with a neutral geometry and 7° clearance.
- PCD edge preparation should be either F or E. An E edge preparation is preferred for larger DOCs, low Co content, and interrupted machining.
- PCBN tools should be used in a negative geometry with 5° to 7° negative rake.
- PCBN edge preparation should be either E or S01025.
- Coolant application is recommended and very important, especially with PCD application where failure is determined by heat generation.
- PCD can also be applied for Co concentrations higher than 19% as long as minimal heat is generated.

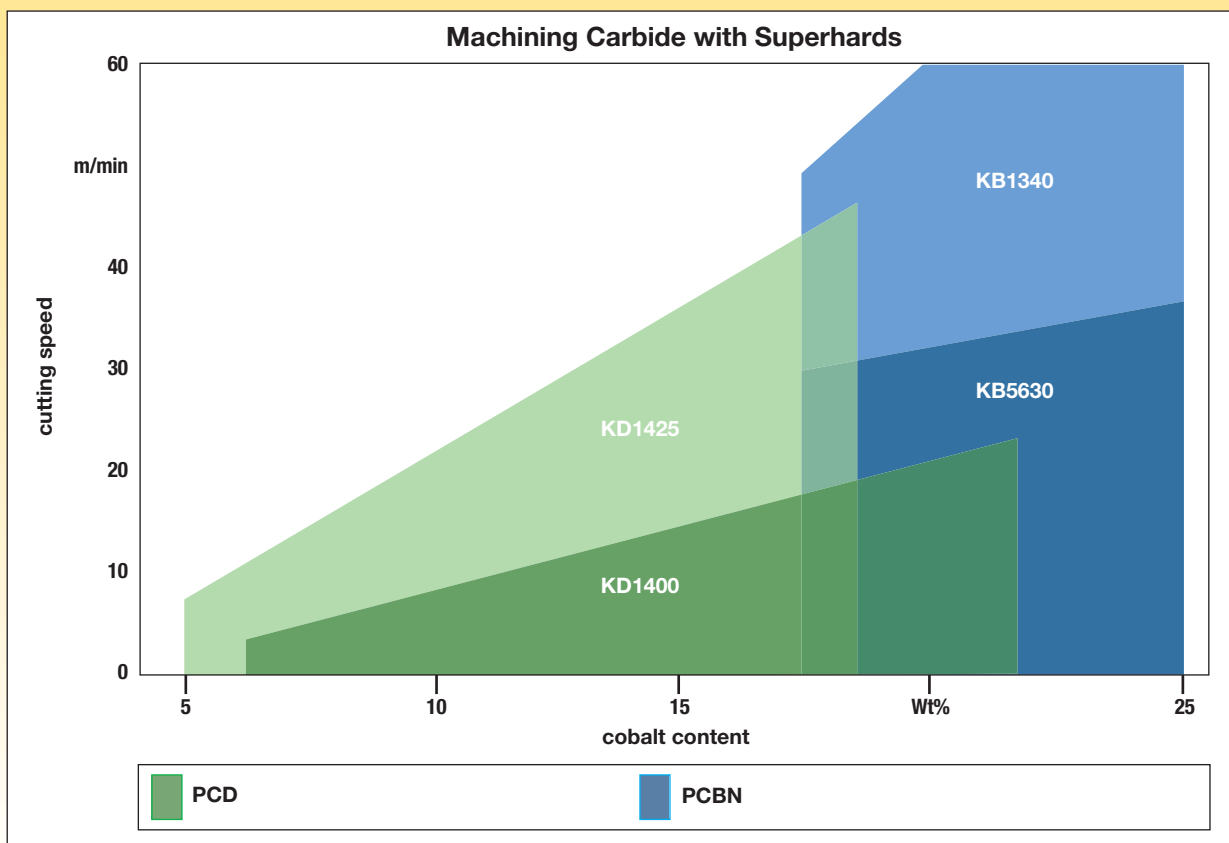

■ CGI boring with turning insert

Machining Parameters

- Feed = 0,1mm (.0038")
- Depth of cut = 0,25mm (.0098")

Tool Life Criteria

- VB max = 0,3mm (.0098")
- Number of bores = 1500

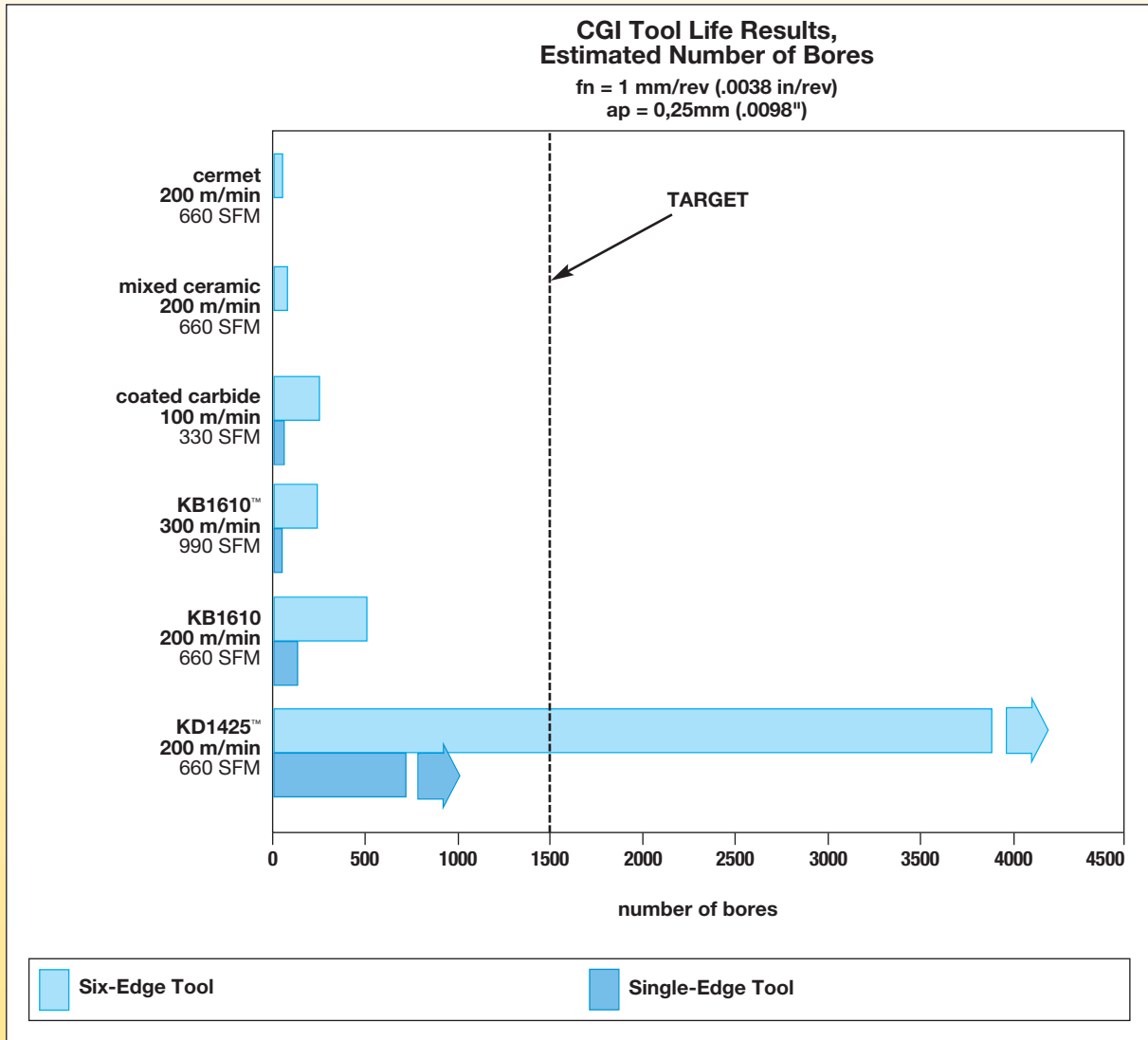

PCBN/PCD Inserts

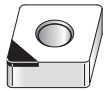

■ CNGA

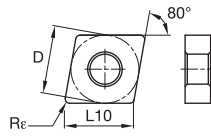

● first choice
○ alternate choice

P																				
M																				
K																				
N																				
S																				
H																				

	D	L10	Re	KB1340	KB1345	KD1400	KD1405	KD1425	KB1610	KB1625	KB1630	KB5610	KB5625	KB5630
ISO catalogue number	mm	mm	mm											
CNGA120404E	12,70	12,90	0,4				●							
CNGA120408E	12,70	12,90	0,8				●							



■ CNGA-EMT

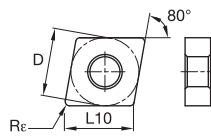

	D	L10	Re	KB1340	KB1345	KD1400	KD1405	KD1425	KB1610	KB1625	KB1630	KB5610	KB5625	KB5630
ISO catalogue number	mm	mm	mm											
CNGA120408EMT	12,70	12,90	0,8										●	
CNGA120412EMT	12,70	12,90	1,2										●	



■ CNGA-FST

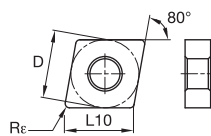

	D	L10	Re	KB1340	KB1345	KD1400	KD1405	KD1425	KB1610	KB1625	KB1630	KB5610	KB5625	KB5630
ISO catalogue number	mm	mm	mm											
CNGA120404FST	12,70	12,90	0,4			●		●						
CNGA120408FST	12,70	12,90	0,8			●		●						



■ CNGA-FW/MW MT

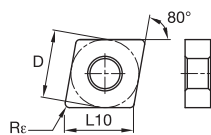

	D	L10	Re	KB1340	KB1345	KD1400	KD1405	KD1425	KB1610	KB1625	KB1630	KB5610	KB5625	KB5630
ISO catalogue number	mm	mm	mm											
CNGA120404S01025FWMT	12,70	12,90	0,4						●			●		●
CNGA120404EFWMT	12,70	12,90	0,4							●			●	
CNGA120408EFWMT	12,70	12,90	0,8						●			●	●	
CNGA120408S01025FWMT	12,70	12,90	0,8						●			●	●	
CNGA120412EFWMT	12,70	12,90	1,2						●				●	
CNGA120416S02015MWMT	12,70	12,90	1,6	●										

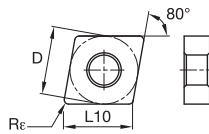
■ CNGA-MT

 ● first choice
 ○ alternate choice

P																						
M																						
K	●	●																				
N			●	○	●																	
S					●												○					○
H	○									●	●	●	●	●	●	●	●	●	●	●	●	●

PCBN/PCD Inserts

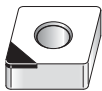
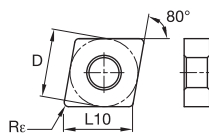
ISO catalogue number	D	L10	Rε	KB1340	KB1345	KD1400	KD1405	KD1425	KB1610	KB1625	KB1630	KB5610	KB5625	KB5630
	mm	mm	mm											
CNGA120404S01025MT	12,70	12,90	0,4							●	●	●	●	●
CNGA120408S01020MT	12,70	12,90	0,8	●										
CNGA120408S02020MT	12,70	12,90	0,8	●										
CNGA120408S01025MT	12,70	12,90	0,8							●	●	●	●	●
CNGA120412S01025MT	12,70	12,90	1,2						●	●		●	●	●
CNGA120412S01020MT	12,70	12,90	1,2											●
CNGA120412T02020MT	12,70	12,90	1,2	●										
CNGA120416S01020MT	12,70	12,90	1,6	●										

■ CNGA-ST

ISO catalogue number	D	L10	Rε	KB1340	KB1345	KD1400	KD1405	KD1425	KB1610	KB1625	KB1630	KB5610	KB5625	KB5630
	mm	mm	mm											
CNGA120404S01025ST	12,70	12,90	0,4									●		
CNGA120408S01025ST	12,70	12,90	0,8									●		
CNGA120412S01025ST	12,70	12,90	1,2									●		

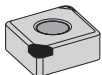
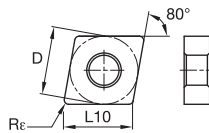
■ CNGM-CB1

ISO catalogue number	D	L10	Rε	KB1340	KB1345	KD1400	KD1405	KD1425	KB1610	KB1625	KB1630	KB5610	KB5625	KB5630
	mm	mm	mm											
CNGM120404S01325MTCB1	12,70	12,90	0,4											●
CNGM120408S01325MTCB1	12,70	12,90	0,8											●
CNGM120412S01325MTCB1	12,70	12,90	1,2											●

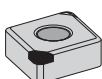
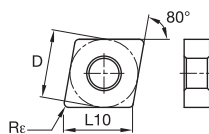
■ CNGM-CB2

ISO catalogue number	D	L10	Rε	KB1340	KB1345	KD1400	KD1405	KD1425	KB1610	KB1625	KB1630	KB5610	KB5625	KB5630
	mm	mm	mm											
CNGM120404S01325MTCB2	12,70	12,90	0,4											●
CNGM120408S01325MTCB2	12,70	12,90	0,8											●
CNGM120412S01325MTCB2	12,70	12,90	1,2											●



PCBN/PCD Inserts

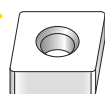

■ CNMA

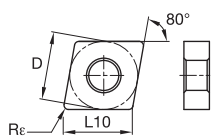

● first choice
○ alternate choice

P																				
M																				
K																				
N																				
S																				
H																				

	D	L10	Re	KB1340	KB1345	KB1400	KD1405	KD1425	KB1610	KB1625	KB1630	KB5610	KB5625	KB5630
ISO catalogue number	mm	mm	mm											
CNMA120408S01025	12,70	12,90	0,8											
CNMA120408S02020	12,70	12,90	0,8	●										
CNMA120412S02020	12,70	12,90	1,2	●										



■ CNMS-E

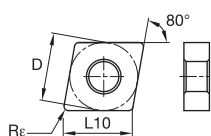

	D	L10	Re	KB1340	KB1345	KB1400	KD1405	KD1425	KB1610	KB1625	KB1630	KB5610	KB5625	KB5630
ISO catalogue number	mm	mm	mm											
CNMS120408E	12,70	12,90	0,8				●							



■ CNMS-FST

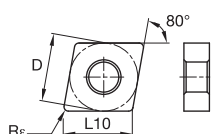

	D	L10	Re	KB1340	KB1345	KB1400	KD1405	KD1425	KB1610	KB1625	KB1630	KB5610	KB5625	KB5630
ISO catalogue number	mm	mm	mm											
CNMS120404FST	12,70	12,90	0,4				●							
CNMS120408FST	12,70	12,90	0,8				●							



■ DNGA

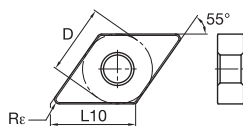

	D	L10	Re	KB1340	KB1345	KB1400	KD1405	KD1425	KB1610	KB1625	KB1630	KB5610	KB5625	KB5630
ISO catalogue number	mm	mm	mm											
DNGA150404E	12,70	15,50	0,4				●							
DNGA150408E	12,70	15,50	0,8				●							

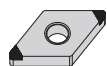

■ DNGA-EMT

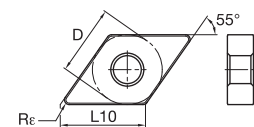

	D	L10	Re	KB1340	KB1345	KB1400	KD1405	KD1425	KB1610	KB1625	KB1630	KB5610	KB5625	KB5630
ISO catalogue number	mm	mm	mm											
DNGA150408EMT	12,70	15,50	0,8				●						●	
DNGA150412EMT	12,70	15,50	1,2										●	

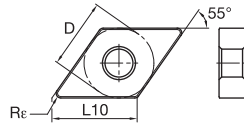

■ DNGA-FST

 ● first choice
 ○ alternate choice

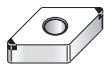
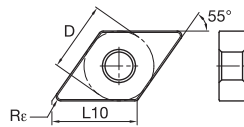
P																						
M																						
K																						
N																						
S																						
H																						

	D	L10	Rε	KB1340	KB1345	KD1400	KD1405	KD1425	KB1610	KB1625	KB1630	KB5610	KB5625	KB5630
ISO catalogue number	mm	mm	mm											
DNGA150404FST	12,70	15,50	0,4			●								
DNGA150408FST	12,70	15,50	0,8			●		●						

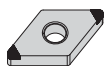
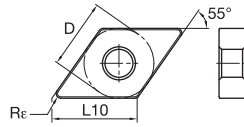
■ DNGA-FW/MW MT

	D	L10	Rε	KB1340	KB1345	KD1400	KD1405	KD1425	KB1610	KB1625	KB1630	KB5610	KB5625	KB5630
ISO catalogue number	mm	mm	mm											
DNGA150404EFWMT	12,70	15,50	0,4											●
DNGA150408EFWMT	12,70	15,50	0,8											●
DNGA150412EFWMT	12,70	15,50	1,2											●

■ DNGA-MT

	D	L10	Rε	KB1340	KB1345	KD1400	KD1405	KD1425	KB1610	KB1625	KB1630	KB5610	KB5625	KB5630
ISO catalogue number	mm	mm	mm											
DNGA150404S01025MT	12,70	15,50	0,4						●		●	●	●	●
DNGA150408S01020MT	12,70	15,50	0,8	●										
DNGA150408S01025MT	12,70	15,50	0,8						●	●	●	●	●	●
DNGA150412S01025MT	12,70	15,50	1,2						●	●		●	●	●

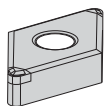
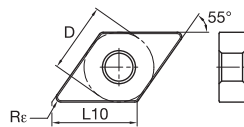

■ DNGM-CB1

	D	L10	Rε	KB1340	KB1345	KD1400	KD1405	KD1425	KB1610	KB1625	KB1630	KB5610	KB5625	KB5630
ISO catalogue number	mm	mm	mm											
DNGM150408S01325MTCB1	12,70	15,50	0,8											●
DNGM150412S01325MTCB1	12,70	15,50	1,2											●

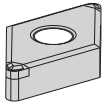

C2-C71	C72-C109	C110-C115	C116-C147	B10-B23	B24-B31	B32-B37

PCBN/PCD Inserts



■ DNGM-CB2

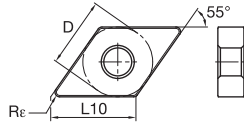

● first choice
○ alternate choice

P																				
M																				
K		●	●																	
N				○	●															
S						●						○								○
H		○						●	●	●	●	●	●	●	●	●	●	●	●	●

ISO catalogue number	D mm	L10 mm	Rε mm	KB1340	KB1345	KD1400	KD1405	KD1425	KB1610	KB1625	KB1630	KB5610	KB5625	KB5630
DNGM150408S01325MTCB2	12,70	15,50	0,8									●		
DNGM150412S01325MTCB2	12,70	15,50	1,2									●		

NOTE: Other insert geometries available upon request.

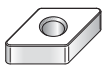

■ DNMA

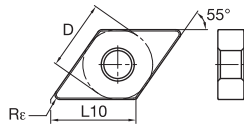

ISO catalogue number	D mm	L10 mm	Rε mm	KB1340	KB1345	KD1400	KD1405	KD1425	KB1610	KB1625	KB1630	KB5610	KB5625	KB5630
DNMA110408S02020	9,53	11,63	0,8	●										
DNMA110412S02020	9,53	11,63	1,2	●										

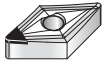

■ DNMS-FST

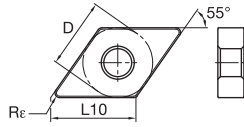

ISO catalogue number	D mm	L10 mm	Rε mm	KB1340	KB1345	KD1400	KD1405	KD1425	KB1610	KB1625	KB1630	KB5610	KB5625	KB5630
DNGA150404FST	12,70	15,50	0,4				●	●						
DNGA150408FST	12,70	15,50	0,8				●	●						



■ SNGA-FW

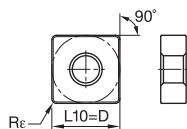

ISO catalogue number	D mm	L10 mm	Rε mm	KB1340	KB1345	KD1400	KD1405	KD1425	KB1610	KB1625	KB1630	KB5610	KB5625	KB5630
SNGA120408S01020FWMT	12,70	12,70	0,8									●		



■ SNGA

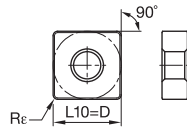

● first choice
○ alternate choice

P																						
M																						
K																						
N																						
S																						
H																						

	D	L10	Re	KB1340	KB1345	KD1400	KD1405	KD1425	KB1610	KB1625	KB1630	KB5610	KB5625	KB5630
ISO catalogue number	mm	mm	mm											
SNGA120404S01025MT	12,70	12,70	0,4											
SNGA120408S01025MT	12,70	12,70	0,8											
SNGA120412S01025MT	12,70	12,70	1,2											

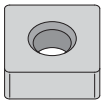

■ SNMA

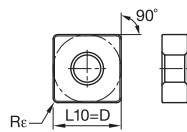

	D	L10	Re	KB1340	KB1345	KD1400	KD1405	KD1425	KB1610	KB1625	KB1630	KB5610	KB5625	KB5630
ISO catalogue number	mm	mm	mm											
SNMA120408S01025	12,70	12,70	0,8											
SNMA120408S02020	12,70	12,70	0,8	●										
SNMA120412S01025	12,70	12,70	1,2											
SNMA120412S02020	12,70	12,70	1,2	●										



■ SNMS-FST

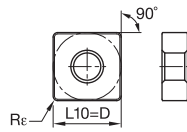

	D	L10	Re	KB1340	KB1345	KD1400	KD1405	KD1425	KB1610	KB1625	KB1630	KB5610	KB5625	KB5630
ISO catalogue number	mm	mm	mm											
SNMS120408FST	12,70	12,70	0,8											
SNMS120412FST	12,70	12,70	1,2											



■ TNGA-FW MT

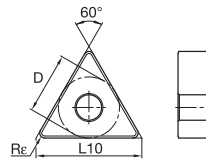

	D	L10	Re	KB1340	KB1345	KD1400	KD1405	KD1425	KB1610	KB1625	KB1630	KB5610	KB5625	KB5630
ISO catalogue number	mm	mm	mm											
TNGA160408EFWMT	9,53	16,50	0,8											
TNGA160412EFWMT	9,53	16,50	1,2											



PCBN/PCD Inserts

C2-C71	C72-C109	C110-C115	C116-C147	B10-B23	B24-B31	B32-B37

PCBN/PCD Inserts



■ TNGA

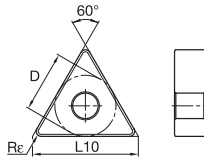

● first choice
○ alternate choice

P																				
M																				
K		●																		
N						○														
S							●													
H		○																		

ISO catalogue number	D mm	L10 mm	Re mm	KB1340	KB1345	KD1400	KD1405	KD1425	KB1610	KB1625	KB1630	KB5610	KB5625	KB5630
TNGA160404S01025MT	9,53	16,50	0,4						●					
TNGA160408S01020MT	9,53	16,50	0,8		●									
TNGA160408S01025MT	9,53	16,50	0,8						●	●				
TNGA160412S01025MT	9,53	16,50	1,2						●	●			●	
TNGA160416S01025MT	9,53	16,50	1,6		●									



■ TNMS-FST

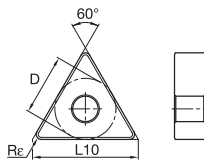

ISO catalogue number	D mm	L10 mm	Re mm	KB1340	KB1345	KD1400	KD1405	KD1425	KB1610	KB1625	KB1630	KB5610	KB5625	KB5630
TNMS160404FST	9,53	16,50	0,4			●		●						
TNMS160408FST	9,53	16,50	0,8			●		●						

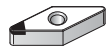

■ VNGA-FST

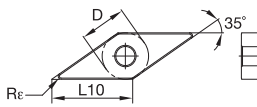

ISO catalogue number	D mm	L10 mm	Re mm	KB1340	KB1345	KD1400	KD1405	KD1425	KB1610	KB1625	KB1630	KB5610	KB5625	KB5630
VNGA160404FST	9,53	16,61	0,40			●		●						
VNGA160408FST	9,53	16,61	0,80			●		●						

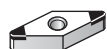

■ VNGA-MT

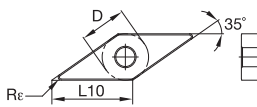

ISO catalogue number	D mm	L10 mm	Re mm	KB1340	KB1345	KD1400	KD1405	KD1425	KB1610	KB1625	KB1630	KB5610	KB5625	KB5630
VNGA160404S01025MT	9,53	16,61	0,4						●	●		●	●	●
VNGA160408S01025MT	9,53	16,61	0,8						●	●		●	●	●



■ VNMS-E

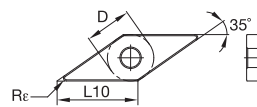

ISO catalogue number	D mm	L10 mm	Re mm	KB1340	KB1345	KD1400	KD1405	KD1425	KB1610	KB1625	KB1630	KB5610	KB5625	KB5630
VNMS160404E	9,53	16,61	0,4					●						
VNMS160408E	9,53	16,61	0,8					●						

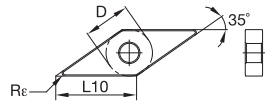

■ VNMS-FST

 ● first choice
 ○ alternate choice

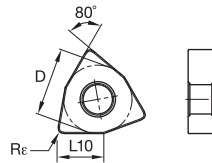
P																				
M																				
K	●																			
N									○											
S										●										
H	○																			

	D	L10	Rε	KB1340	KB1345	KD1400	KD1405	KD1425	KB1610	KB1625	KB1630	KB5610	KB5625	KB5630
ISO catalogue number	mm	mm	mm											
VNMS160404FST	9,53	16,61	0,4			●		●						
VNMS160408FST	9,53	16,61	0,8			●		●						

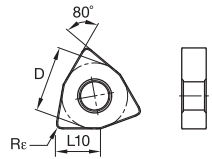
■ WNGA-FST

	D	L10	Rε	KB1340	KB1345	KD1400	KD1405	KD1425	KB1610	KB1625	KB1630	KB5610	KB5625	KB5630
ISO catalogue number	mm	mm	mm											
WNGA080404FST	12,70	8,69	0,4											
WNGA080408FST	12,70	8,69	0,8			●		●						

■ WNGA-FW/MT

	D	L10	Rε	KB1340	KB1345	KD1400	KD1405	KD1425	KB1610	KB1625	KB1630	KB5610	KB5625	KB5630
ISO catalogue number	mm	mm	mm											
WNGA080412S01020FWMT	12,70	8,69	1,2									●		

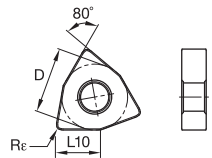
■ WNGA

	D	L10	Rε	max	KB1340	KB1345	KD1400	KD1405	KD1425	KB1610	KB1625	KB1630	KB5610	KB5625	KB5630
ISO catalogue number	mm	mm	mm	mm											
WNGA080404S01025MT	12,70	8,69	0,4	1,60									●		
WNGA080408S01025MT	12,70	8,69	0,8	1,12									●		



PCBN/PCD Inserts

C2-C71	C72-C109	C110-C115	C116-C147	B10-B23	B24-B31	B32-B37

PCBN/PCD Inserts

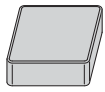

■ CNMN

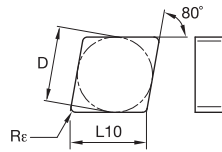

● first choice
○ alternate choice

P																				
M																				
K		●	●																	
N						●	○	●												
S						●						○								○
H		○							●	●	●	●	●	●	●	●	●	●	●	●

ISO catalogue number	D mm	L10 mm	Re mm	KB1340	KB1345	KD1400	KD1405	KD1425	KB1610	KB1625	KB1630	KB5610	KB5625	KB5630
CNMN090308S02020	9,53	9,67	0,8	●										
CNMN090312S02020	9,53	9,67	1,2	●										
CNMN120408S02020	12,70	12,90	0,8	●										
CNMN120412S02020	12,70	12,90	1,2	●										

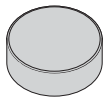

■ RNMN

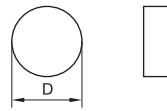

ISO catalogue number	D mm	L10 mm	Re mm	KB1340	KB1345	KD1400	KD1405	KD1425	KB1610	KB1625	KB1630	KB5610	KB5625	KB5630
RNMN090300S02020	9,53	—	—	●										
RNMN120300S02020	12,70	—	—	●										
RNMN120400S02020	12,70	—	—	●										

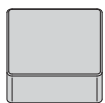

■ SNMN

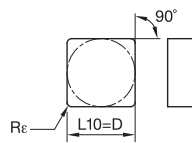

ISO catalogue number	D mm	L10 mm	Re mm	KB1340	KB1345	KD1400	KD1405	KD1425	KB1610	KB1625	KB1630	KB5610	KB5625	KB5630
SNMN090308S02020	9,53	9,53	0,8	●										
SNMN090312S02020	9,53	9,53	1,2	●										
SNMN090316S02020	9,53	9,53	1,6	●										
SNMN120308S02020	12,70	12,70	0,8	●										
SNMN120312S02020	12,70	12,70	1,2	●										
SNMN120316S02020	12,70	12,70	1,6	●										
SNMN120416T02020	12,70	12,70	1,6	●										

PCBN/PCD Inserts



■ SNGX

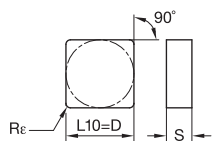

● first choice
○ alternate choice

P																				
M																				
K		●	●																	
N						●	○	●												
S						●					○									○
H		○								●	●	●	●	●	●	●	●	●	●	●

	D	L10	Re																	
ISO catalogue number	mm	mm	mm		KB1340	KB1345	KB1400	KB1405	KB1425	KB1610	KB1625	KB1630	KB1630	KB5610	KB5625	KB5630				
SNGX120416S02020	12,70	12,70	1,6	●																
SNGX150416S02020	15,88	15,88	1,6	●																



■ VNGX

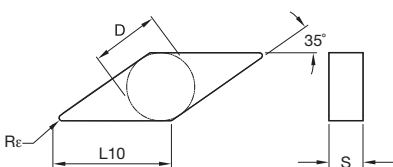

	D	L10	Re																	
ISO catalogue number	mm	mm	mm		KB1340	KB1345	KB1400	KB1405	KB1425	KB1610	KB1625	KB1630	KB1630	KB5610	KB5625	KB5630				
VNGX160412S02020	9,53	16,61	1,2	●																

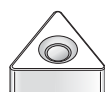

■ TNGX-FW

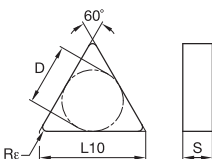

	D	L10	Re																	
ISO catalogue number	mm	mm	mm		KB1340	KB1345	KB1400	KB1405	KB1425	KB1610	KB1625	KB1630	KB1630	KB5610	KB5625	KB5630				
TNGX160412EFW	9,53	16,50	1,2	●																

■ Clamp Selection Chart

MM	insert	clamp	clamp
	ISO catalogue number		
3960807	CNGX120412S01015	551.718 - 100° Corner	551.716 - 80° Corner
3960808	CNGX120412S01015FW	551.718 - 100° Corner	551.716 - 80° Corner
3960806	CNGX120416S02020	551.718 - 100° Corner	551.716 - 80° Corner
3960811	DNGX150416S02020	551.720	551.720
3960812	SNGX120416S02020	551.718	551.718
3960823	SNGX150416S02020	551.718	551.718
3960824	VNGX160412S02020	551.721	551.721
3876843	CNGF120408	551.718 - 100° Corner	551.716 - 80° Corner
3960825	TNGX160412EFW	551.733	551.733



■ CPG

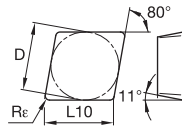

● first choice
○ alternate choice

P																				
M																				
K	●																			
N																				
S																				
H	○																			

	D	L10	Re	KB1340	KB1345	KB1400	KD1405	KD1425	KB1610	KB1625	KB1630	KB5610	KB5625	KB5630
ISO catalogue number	mm	mm	mm											
CPGN120304F	12,70	12,90	0,4					●						
CPGN120308F	12,70	12,90	0,8					●						



■ CPG-MT

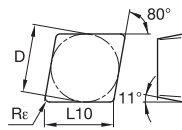

	D	L10	Re	KB1340	KB1345	KB1400	KD1405	KD1425	KB1610	KB1625	KB1630	KB5610	KB5625	KB5630
ISO catalogue number	mm	mm	mm											
CPGN120304S01015MT	12,70	12,90	0,4									●		
CPGN120308S01015MT	12,70	12,90	0,8									●		



■ TPG

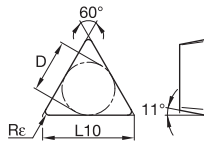

	D	L10	Re	KB1340	KB1345	KB1400	KD1405	KD1425	KB1610	KB1625	KB1630	KB5610	KB5625	KB5630
ISO catalogue number	mm	mm	mm											
TPGN110304F	6,35	11,00	0,4											●
TPGN110308F	6,35	11,00	0,8											●
TPGN160304F	9,53	16,50	0,4											●
TPGN160308F	9,53	16,50	0,8											●
TPGN160312F	9,53	16,50	1,2											●
TPGN220404F	12,70	22,00	0,4											●
TPGN220408F	12,70	22,00	0,8											●



PCBN/PCD Inserts



PCBN/PCD Inserts



■ TPG-M

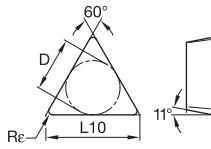

● first choice
○ alternate choice

P																				
M																				
K	●	●																		
N			●	○	●															
S				●							○									○
H	○								●	●	●	●	●	●	●	●	●	●	●	●

	D	L10	Re	KB1340	KB1345	KD1400	KD1405	KD1425	KB1610	KB1625	KB1630	KB5610	KB5625	KB5630
ISO catalogue number	mm	mm	mm											
TPGN110304EM	6,35	11,00	0,4									●		
TPGN110304S01020M	6,35	11,00	0,4									●		
TPGN160304EM	9,53	16,50	0,4									●		
TPGN160304S01020M	9,53	16,50	0,4									●		
TPGN160308EM	9,53	16,50	0,8									●		



■ TPG-MT

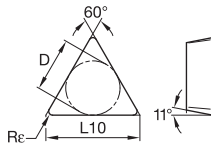

	D	L10	Re	KB1340	KB1345	KD1400	KD1405	KD1425	KB1610	KB1625	KB1630	KB5610	KB5625	KB5630
ISO catalogue number	mm	mm	mm											
TPGN160304S01015MT	9,53	16,50	0,4									●		
TPGN160308S01015MT	9,53	16,50	0,8									●		
TPGN220404S01015MT	12,70	22,00	0,4									●		
TPGN220408S01015MT	12,70	22,00	0,8									●		

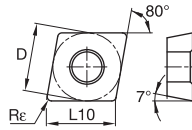

■ CCGW-C

 ● first choice
 ○ alternate choice

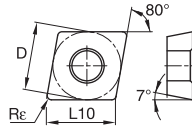
P																				
M																				
K	●	●																		
N				●	○															
S						●							○							○
H	○										●	●	●	●	●	●	●	●	●	●

	D	L10	Re	KB1340	KB1345	KD1400	KD1405	KD1425	KB1610	KB1625	KB1630	KB5610	KB5625	KB5630
ISO catalogue number	mm	mm	mm											
CCGW060202EC	6,35	6,45	0,2											
CCGW060202S01015C	6,35	6,45	0,2							●				
CCGW060204S01015C	6,35	6,45	0,4							●				
CCGW09T304S01015C	9,53	9,67	0,4											
CCGW09T308EC	9,53	9,67	0,8	●										
CCGW09T308S01015C	9,53	9,67	0,8										●	

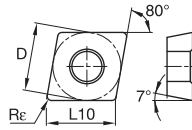
■ CCGW-EMT

	D	L10	Re	KB1340	KB1345	KD1400	KD1405	KD1425	KB1610	KB1625	KB1630	KB5610	KB5625	KB5630
ISO catalogue number	mm	mm	mm											
CCGW09T304EMT	9,53	9,67	0,4									●		

■ CCGW-FST

	D	L10	Re	KB1340	KB1345	KD1400	KD1405	KD1425	KB1610	KB1625	KB1630	KB5610	KB5625	KB5630
ISO catalogue number	mm	mm	mm											
CCGW060204FST	6,35	6,45	0,4			●								
CCGW09T304FST	9,53	9,67	0,4			●								
CCGW09T308FST	9,53	9,67	0,8			●		●						

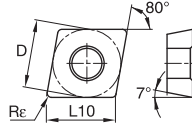
■ CCGW-FWC

	D	L10	Re	KB1340	KB1345	KD1400	KD1405	KD1425	KB1610	KB1625	KB1630	KB5610	KB5625	KB5630
ISO catalogue number	mm	mm	mm											
CCGW060202EFWC	6,35	6,45	0,2											●
CCGW060204EFWC	6,35	6,45	0,4											●
CCGW09T304EFWC	9,53	9,67	0,4											●
CCGW09T308EFWC	9,53	9,67	0,8											●



PCBN/PCD Inserts

C2-C71	C72-C109	C110-C115	C116-C147	B10-B23	B24-B31	B32-B37

PCBN/PCD Inserts



■ CCGW-FWM

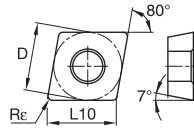

● first choice
○ alternate choice

P																				
M																				
K	●	●																		
N			●	○	●															
S				●						○										○
H	○									●	●	●	●	●	●	●	●	●	●	●

	D	L10	Re	KB1340	KB1345	KD1400	KD1405	KD1425	KB1610	KB1625	KB1630	KB5610	KB5625	KB5630
ISO catalogue number	mm	mm	mm											
CCGW060202EFWM	6,35	6,45	0,2										●	
CCGW060204EFWM	6,35	6,45	0,4										●	
CCGW09T304EFWM	9,53	9,67	0,4										●	
CCGW09T308EFWM	9,53	9,67	0,8										●	

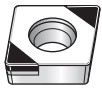

■ CCGW-FWMT

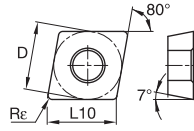

	D	L10	Re	KB1340	KB1345	KD1400	KD1405	KD1425	KB1610	KB1625	KB1630	KB5610	KB5625	KB5630
ISO catalogue number	mm	mm	mm											
CCGW09T304S01015FWMT	9,53	9,67	0,4						●					
CCGW09T308S01015FWMT	9,53	9,67	0,8						●					



■ CCGW-M

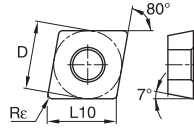

	D	L10	Re	KB1340	KB1345	KD1400	KD1405	KD1425	KB1610	KB1625	KB1630	KB5610	KB5625	KB5630
ISO catalogue number	mm	mm	mm											
CCGW060202EM	6,35	6,45	0,2										●	
CCGW060204S01015M	6,35	6,45	0,4										●	
CCGW09T304S01015M	9,53	9,67	0,4										●	
CCGW09T308S01015M	9,53	9,67	0,8										●	



■ CCGW-MT

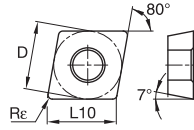

	D	L10	Re	KB1340	KB1345	KD1400	KD1405	KD1425	KB1610	KB1625	KB1630	KB5610	KB5625	KB5630
ISO catalogue number	mm	mm	mm											
CCGW09T304S01015MT	9,53	9,67	0,4						●	●	●	●	●	●
CCGW09T308S01015MT	9,53	9,67	0,8						●	●	●	●	●	●
CCGW120404S01015MT	12,70	12,90	0,4	●										
CCGW120408S01015MT	12,70	12,90	0,8	●						●				



■ **CDHB**

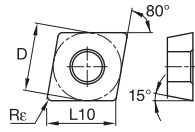

● first choice
○ alternate choice

P																				
M																				
K		●	●																	
N				●		○		●												
S						●										○				○
H	○							●			●	●	●	●	●	●	●	●	●	●

	D	L10	Re	KB1340	KB1345	KD1400	KD1405	KD1425	KB1610	KB1625	KB1630	KB5610	KB5625	KB5630
ISO catalogue number	mm	mm	mm											
CDHBS4T0S0	3,97	4,03	0,1										●	
CDHBS4T002	3,97	4,03	0,2										●	
CDHBS4T004	3,97	4,03	0,4										●	



■ **CDHB-FST**

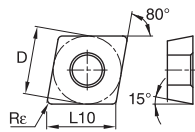

	D	L10	Re	KB1340	KB1345	KD1400	KD1405	KD1425	KB1610	KB1625	KB1630	KB5610	KB5625	KB5630
ISO catalogue number	mm	mm	mm											
CDHBS4T004FST	3,97	4,03	0,1			●		●						
CDHBS4T002FST	3,97	4,03	0,2			●		●						

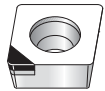

■ **CPGW-E**

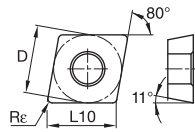

	D	L10	Re	KB1340	KB1345	KD1400	KD1405	KD1425	KB1610	KB1625	KB1630	KB5610	KB5625	KB5630
ISO catalogue number	mm	mm	mm											
CPGW060204E	6,35	6,45	0,4					●						
CPGW09T304E	9,53	9,67	0,4					●						
CPGW09T308E	9,53	9,67	0,8					●						



■ **CPGW-FWC**

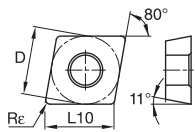

	D	L10	Re	KB1340	KB1345	KD1400	KD1405	KD1425	KB1610	KB1625	KB1630	KB5610	KB5625	KB5630
ISO catalogue number	mm	mm	mm											
CPGW060202EFC	6,35	6,45	0,2										●	
CPGW060204EFC	6,35	6,45	0,4										●	



PCBN/PCD Inserts

C2-C71	C72-C109	C110-C115	C116-C147	B10-B23	B24-B31	B32-B37

PCBN/PCD Inserts

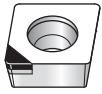

■ CPGW-FWM

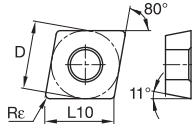

● first choice
○ alternate choice

P																				
M																				
K	●	●																		
N				●	○	●														
S					●					○										○
H	○								●	●	●	●	●	●	●	●	●	●	●	●

	D	L10	Re	KB1340	KB1345	KB1400	KD1405	KD1425	KB1610	KB1625	KB1630	KB5610	KB5625	KB5630
ISO catalogue number	mm	mm	mm											
CPGW060202EFWM	6,35	6,45	0,2									●		
CPGW060204EFWM	6,35	6,45	0,4									●		
CPGW060208EFWM	6,35	6,45	0,8									●		



■ CPGW-FWMT

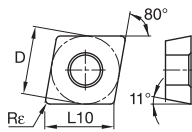

	D	L10	Re	KB1340	KB1345	KB1400	KD1405	KD1425	KB1610	KB1625	KB1630	KB5610	KB5625	KB5630
ISO catalogue number	mm	mm	mm											
CPGW09T304S01015FWMT	9,53	9,67	0,4						●					
CPGW09T308S01015FWMT	9,53	9,67	0,8						●					

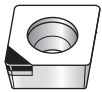

■ CPGW-FWST

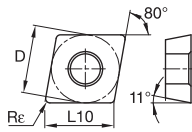

	D	L10	Re	KB1340	KB1345	KB1400	KD1405	KD1425	KB1610	KB1625	KB1630	KB5610	KB5625	KB5630
ISO catalogue number	mm	mm	mm											
CPGW060204FWST	6,35	6,45	0,4			●		●						
CPGW09T308FWST	9,53	9,67	0,8			●		●						
CPGW120408FWST	12,70	12,90	0,8			●		●						



■ CPGW-ST

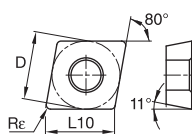

	D	L10	Re	KB1340	KB1345	KB1400	KD1405	KD1425	KB1610	KB1625	KB1630	KB5610	KB5625	KB5630
ISO catalogue number	mm	mm	mm											
CPGW060202FST	6,35	6,45	0,2			●		●						
CPGW060204FST	6,35	6,45	0,4			●		●						
CPGW060208FST	6,35	6,45	0,8			●		●						
CPGW09T304FST	9,53	9,67	0,4			●		●						
CPGW09T308FST	9,53	9,67	0,8			●		●						
CPGW120404FST	12,70	12,90	0,4			●		●						
CPGW120408FST	12,70	12,90	0,8			●		●						

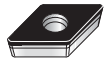

■ DCGW-C

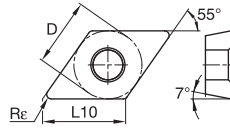

● first choice
○ alternate choice

P																				
M																				
K	●	●																		
N			●	○	●															
S				●																
H	○																			

	D	L10	Re	KB1340	KB1345	KD1400	KD1405	KD1425	KB1610	KB1625	KB1630	KB5610	KB5625	KB5630
ISO catalogue number	mm	mm	mm											
DCGW070202EC	6,35	7,75	0,2											
DCGW070202S01015C	6,35	7,75	0,2						●			●	●	
DCGW070204S01015C	6,35	7,75	0,4						●			●	●	●

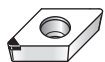

■ DCGW-FWM

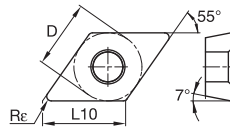

	D	L10	Re	KB1340	KB1345	KD1400	KD1405	KD1425	KB1610	KB1625	KB1630	KB5610	KB5625	KB5630
ISO catalogue number	mm	mm	mm											
DCGW070204EFWM	6,35	7,75	0,4									●		

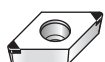

■ DCGW-FWMT

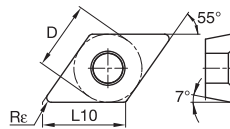

	D	L10	Re	KB1340	KB1345	KD1400	KD1405	KD1425	KB1610	KB1625	KB1630	KB5610	KB5625	KB5630
ISO catalogue number	mm	mm	mm											
DCGW11T304EFWMT	9,53	11,63	0,4									●	●	
DCGW11T308S01015FWMT	9,53	11,63	0,8									●	●	



■ DCGW-M

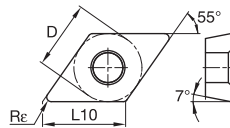

	D	L10	Re	KB1340	KB1345	KD1400	KD1405	KD1425	KB1610	KB1625	KB1630	KB5610	KB5625	KB5630
ISO catalogue number	mm	mm	mm											
DCGW070202EM	6,35	7,75	0,2									●	●	
DCGW070204EM	6,35	7,75	0,4									●	●	
DCGW070204S01015M	6,35	7,75	0,4									●	●	
DCGW11T304S01015M	9,53	11,63	0,4									●	●	
DCGW11T308S01015M	9,53	11,63	0,8									●	●	



PCBN/PCD Inserts

C2-C71	C72-C109	C110-C115	C116-C147	B10-B23	B24-B31	B32-B37

PCBN/PCD Inserts

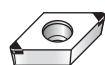

■ DCGW-MT

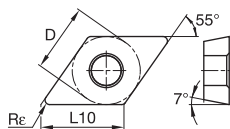

● first choice
○ alternate choice

P																				
M																				
K	●	●																		
N				●	○	●														
S						●					○									○
H	○									●	●	●	●	●	●	●	●	●	●	●

	D	L10	Re	KB1340	KB1345	KD1400	KD1405	KD1425	KB1610	KB1625	KB1630	KB5610	KB5625	KB5630
ISO catalogue number	mm	mm	mm											
DCGW11T304S01015MT	9,53	11,63	0,4	●					●	●				
DCGW11T308S01015MT	9,53	11,63	0,8	●					●	●				

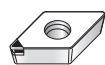

■ DCGW-ST

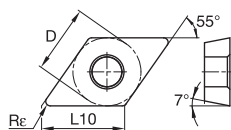

	D	L10	Re	KB1340	KB1345	KD1400	KD1405	KD1425	KB1610	KB1625	KB1630	KB5610	KB5625	KB5630
ISO catalogue number	mm	mm	mm											
DCGW070204FST	6,35	7,75	0,4			●		●						
DCGW11T304FST	9,53	11,63	0,4			●		●						



■ DPGW-C

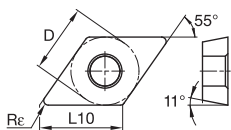

	D	L10	Re	KB1340	KB1345	KD1400	KD1405	KD1425	KB1610	KB1625	KB1630	KB5610	KB5625	KB5630
ISO catalogue number	mm	mm	mm											
DPGW070202EC	6,35	7,75	0,2											●
DPGW070204S01015C	6,35	7,75	0,4											●
DPGW070208S01015C	6,35	7,75	0,8											●



■ DPGW-E

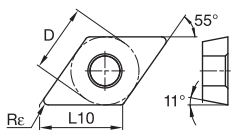

	D	L10	Re	KB1340	KB1345	KD1400	KD1405	KD1425	KB1610	KB1625	KB1630	KB5610	KB5625	KB5630
ISO catalogue number	mm	mm	mm											
DPGW070202E	6,35	7,75	0,2				●							
DPGW11T304E	9,53	11,63	0,4				●							



■ DPGW-EMT

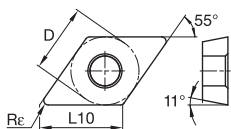

	D	L10	Re	KB1340	KB1345	KD1400	KD1405	KD1425	KB1610	KB1625	KB1630	KB5610	KB5625	KB5630
ISO catalogue number	mm	mm	mm											
DPGW11T304EMT	9,53	11,63	0,4	●										



■ DPGW-FST

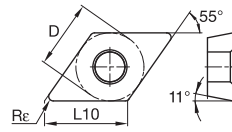

● first choice
○ alternate choice

P																				
M																				
K		●																		
N																				
S																				
H	○																			

	D	L10	Re	KB1340	KB1345	KD1400	KD1405	KD1425	KB1610	KB1625	KB1630	KB5610	KB5625	KB5630
ISO catalogue number	mm	mm	mm											
DPGW070202FST	6,35	7,75	0,2		●									
DPGW070204FST	6,35	7,75	0,4		●			●						
DPGW11T304FST	9,53	11,63	0,4			●		●						



■ DPGW-FWM

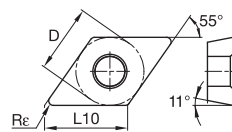

	D	L10	Re	KB1340	KB1345	KD1400	KD1405	KD1425	KB1610	KB1625	KB1630	KB5610	KB5625	KB5630
ISO catalogue number	mm	mm	mm											
DPGW070204S01015FWM	6,35	7,75	0,4										●	



■ DPGW-FWST

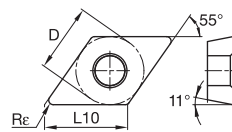

	D	L10	Re	KB1340	KB1345	KD1400	KD1405	KD1425	KB1610	KB1625	KB1630	KB5610	KB5625	KB5630
ISO catalogue number	mm	mm	mm											
DPGW070204FWST	6,35	7,75	0,2			●		●						
DPGW11T304FWST	9,53	11,63	0,2			●		●						



■ DPGW-M

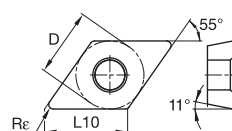

	D	L10	Re	KB1340	KB1345	KD1400	KD1405	KD1425	KB1610	KB1625	KB1630	KB5610	KB5625	KB5630
ISO catalogue number	mm	mm	mm											
DPGW070202EM	6,35	7,75	0,2											●
DPGW070204S01015M	6,35	7,75	0,4											●
DPGW070208S01015M	6,35	7,75	0,8											●
DPGW11T304S01015M	9,53	11,63	0,4											●
DPGW11T308S01015M	9,53	11,63	0,8											●



C2-C71	C72-C109	C110-C115	C116-C147	B10-B23	B24-B31	B32-B37

PCBN/PCD Inserts



■ DPGW-MT

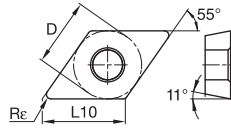

● first choice
○ alternate choice

P																				
M																				
K		●	●																	
N						●	○	●												
S								●						○						○
H		○								●	●	●	●	●	●	●	●	●	●	●

	D	L10	Re	KB1340	KB1345	KD1400	KD1405	KD1425	KB1610	KB1625	KB1630	KB5610	KB5625	KB5630
ISO catalogue number	mm	mm	mm											
DPGW11T304S01015MT	9,53	11,63	0,4						●	●	●			
DPGW11T308S01015MT	9,53	11,63	0,8						●	●	●			



■ TCGW-C

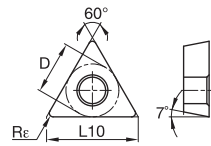

	D	L10	Re	KB1340	KB1345	KD1400	KD1405	KD1425	KB1610	KB1625	KB1630	KB5610	KB5625	KB5630
ISO catalogue number	mm	mm	mm											
TCGW110202EC	6,35	11,00	0,20											●
TCGW110202S01015C	6,35	11,00	0,20						●					
TCGW110204S01015C	6,35	11,00	0,40						●					●



■ TCGW-FST

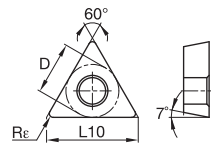

	D	L10	Re	KB1340	KB1345	KD1400	KD1405	KD1425	KB1610	KB1625	KB1630	KB5610	KB5625	KB5630
ISO catalogue number	mm	mm	mm											
TCGW110204FST	6,35	11,00	0,40			●		●						
TCGW16T304FST	9,53	16,50	0,40			●		●						



■ TCGW-M

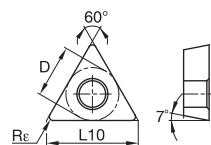

	D	L10	Re	KB1340	KB1345	KD1400	KD1405	KD1425	KB1610	KB1625	KB1630	KB5610	KB5625	KB5630
ISO catalogue number	mm	mm	mm											
TCGW110202EM	6,35	11,00	0,2											●
TCGW110204S01015M	6,35	11,00	0,4											●
TCGW16T304S01015M	9,53	16,50	0,4											●
TCGW16T308S01015M	9,53	16,50	0,8											●

TCGW-MT

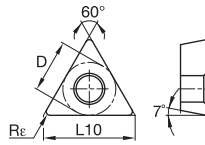

● first choice
○ alternate choice

P														
M														
K		●												
N			○											
S				●										
H	○													

ISO catalogue number	D mm	L10 mm	Rε mm	KB1340	KB1345	KD1400	KD1405	KD1425	KB1610	KB1625	KB1630	KB5610	KB5625	KB5630
TCGW16T304S01015MT	9,53	16,50	0,4							●				

TDHB

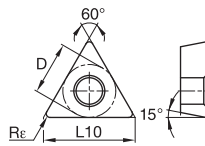

ISO catalogue number	D mm	L10 mm	Rε mm	KB1340	KB1345	KD1400	KD1405	KD1425	KB1610	KB1625	KB1630	KB5610	KB5625	KB5630
TDHB07T1202	4,06	7,04	0,2											●

TPGW

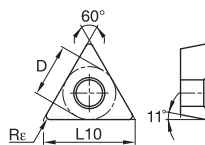

ISO catalogue number	D mm	L10 mm	Rε mm	KB1340	KB1345	KD1400	KD1405	KD1425	KB1610	KB1625	KB1630	KB5610	KB5625	KB5630
TPGW110208E	6,35	11,00	0,80				●							

TPGW-C

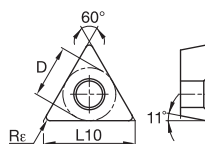

ISO catalogue number	D mm	L10 mm	Rε mm	KB1340	KB1345	KD1400	KD1405	KD1425	KB1610	KB1625	KB1630	KB5610	KB5625	KB5630
TPGW110202EC	6,35	11,00	0,20											●
TPGW110204EC	6,35	11,00	0,40				●							
TPGW110204S01015C	6,35	11,00	0,40							●		●	●	●
TPGW110208S01015C	6,35	11,00	0,80							●		●	●	●



C2-C71	C72-C109	C110-C115	C116-C147	B10-B23	B24-B31	B32-B37

PCBN/PCD Inserts



■ TPGW-FST

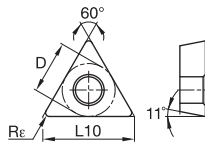

● first choice
○ alternate choice

P																				
M																				
K		●	●																	
N				●	○	●														
S				●						○										○
H	○									●	●	●	●	●	●	●	●	●	●	●

	D	L10	Re	KB1340	KB1345	KD1400	KD1405	KD1425	KB1610	KB1625	KB1630	KB5610	KB5625	KB5630
ISO catalogue number	mm	mm	mm											
TPGW110204FST	6,35	11,00	0,4			●		●						
TPGW110208FST	6,35	11,00	0,8			●		●						
TPGW16T304FST	9,53	16,50	0,4			●								
TPGW16T308FST	9,53	16,50	0,8			●		●						



■ TPGW-M

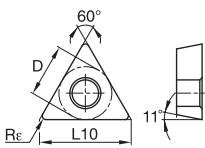

	D	L10	Re	KB1340	KB1345	KD1400	KD1405	KD1425	KB1610	KB1625	KB1630	KB5610	KB5625	KB5630
ISO catalogue number	mm	mm	mm											
TPGW110202EM	6,35	11,00	0,2											●
TPGW110204S01015M	6,35	11,00	0,4											●
TPGW110208S01015M	6,35	11,00	0,8											●
TPGW16T304S01015M	9,53	16,50	0,4											●
TPGW16T308S01015M	9,53	16,50	0,8											●



■ TPGW-MT

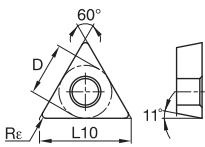

	D	L10	Re	KB1340	KB1345	KD1400	KD1405	KD1425	KB1610	KB1625	KB1630	KB5610	KB5625	KB5630
ISO catalogue number	mm	mm	mm											
TPGW16T308S01015MT	9,53	16,50	0,8							●				

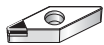

■ VBGW-E

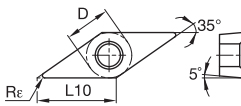

	D	L10	Re	KB1340	KB1345	KD1400	KD1405	KD1425	KB1610	KB1625	KB1630	KB5610	KB5625	KB5630
ISO catalogue number	mm	mm	mm											
VBGW160408E	9,53	16,61	0,8				●							

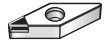

■ VBGW-FST

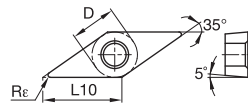

● first choice
○ alternate choice

P																				
M																				
K	●																			
N		●																		
S																				
H	○																			

	D	L10	Re	KB1340	KB1345	KB1400	KD1405	KD1425	KB1610	KB1625	KB1630	KB5610	KB5625	KB5630
ISO catalogue number	mm	mm	mm											
VBGW110304FST	6,35	11,07	0,4			●								
VBGW160404FST	9,53	16,61	0,4		●		●							

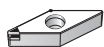

■ VBGW-M

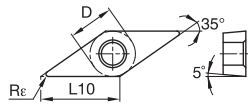

	D	L10	Re	KB1340	KB1345	KB1400	KD1405	KD1425	KB1610	KB1625	KB1630	KB5610	KB5625	KB5630
ISO catalogue number	mm	mm	mm											
VBGW160404S01015M	9,53	16,61	0,4										●	
VBGW160408S01015M	9,53	16,61	0,8										●	



■ VBGW-MT

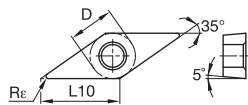

	D	L10	Re	KB1340	KB1345	KB1400	KD1405	KD1425	KB1610	KB1625	KB1630	KB5610	KB5625	KB5630
ISO catalogue number	mm	mm	mm											
VBGW160404S01015MT	9,53	16,61	0,4						●	●		●		●
VBGW160408S01015MT	9,53	16,61	0,8						●	●		●		●



PCBN/PCD Inserts

C2-C71	C72-C109	C110-C115	C116-C147	B10-B23	B24-B31	B32-B37



Toolholders, Boring Bars, and Cartridges

Toolholders	C2-C71
Toolholder Selection Guide	C2-C3
Kenclamp	C6-C15
Kenlever	C16-C22
Fix-Perfect	C23
Kenloc	C24-C33
Wedgelock	C34
Kendex	C36-C39
Screw-On	C40-C55
V-Bottom	C56
MTS	C58-C71
Boring Bars	C72-C115
Boring Bar Selection Guide	C72-C73
Kenclamp	C76-C79
Kenloc	C80-C82
Kendex	C83-C84
Screw-On	C85-C102
Kenlever	C103-C104
MTS	C105-C107
Boring Heads	C108-C115
Cartridges	C116-C147
Kenloc	C120-C129
Kenlever	C130-C131
Kendex	C132-C136
Screw-On	C137-C147

tool path	insert shape	clamping style	turning	profiling	facing	plunging	chamfering	page(s)
117,5° Lead Angle								
		Kenloc™	•	•				C33
		Kenclamp	•		•			C14
107,5° Lead Angle								
		Screw-On	•	•				C47
		MTS	•			•		C63
		Screw-On	•	•				C55
97,5° Lead Angle								
		MTS	•		•			C65
95° Lead Angle								
		Kenloc	•	•	•			C24
		Kenclamp	•	•	•			C6
		Kenlever	•	•	•			C16
		Screw-On	•	•	•			C45
		MTS	•	•	•			C62
		Kenloc	•	•	•			C33
		Kenclamp	•	•	•			C15
		Kenlever	•	•	•			C22
		Screw-On	•	•	•			C57
		MTS	•	•	•			C73
WedgeLock™	•	•	•			C34		
93° Lead Angle								
		Kenloc	•	•				C26
		Kenclamp	•	•				C8
		Kenlever	•	•				C18
		Screw-On	•	•				C48
	MTS	•	•				C64	
	Kenloc	•	•				C32	
	Kenclamp	•	•				C13	
	Screw-On	•	•				C56	
	WedgeLock	•	•				C34	

tool path	insert shape	clamping style	turning	profiling	facing	plunging	chamfering	page(s)
90° Lead Angle								
		Screw-On	•		•			C44
		Screw-On	•	•				C47
		Screw-On	•	•				C55
		Kenloc	•	•		•		C32
		Kenclamp	•		•			C13
		Kenlever™	•		•			C21
		Kendex™	•		•			C41
		Screw-On	•		•			C54
MTS	•		•				C72	
85° Lead Angle								
		MTS	•		•			C71
75° Lead Angle								
		Kenloc	•		•			C26
		Kenclamp	•		•			C6
		Kenlever	•		•			C15
		Kendex	•					C38
		Screw-On	•		•			C46
	MTS	•					C63	
			Kenloc	•		•		
Kenclamp			•		•			C11
Kenlever			•		•			C20
Screw-On			•		•			C52
MTS	•		•			C68-C69		
72,5° Lead Angle								
		Kenloc	•	•				C33
		Kenclamp	•		•			C14
		Screw-On	•	•				C57

tool path	insert shape	clamping style	turning	profiling	facing	plunging	chamfering	page(s)
70° Lead Angle 	E	MTS	•					–
63° Lead Angle 	D	Kenclamp	•	•				C9
62,5° Lead Angle 	D	Kenloc	•	•				C27
		Kenlever	•	•				C18
		Screw-On	•	•				C49
60° Lead Angle 	T	Kenloc	•	•				C31
		Kendex	•					–
		Screw-On	•	•	•			–

tool path	insert shape	clamping style	turning	profiling	facing	plunging	chamfering	page(s)
50° Lead Angle 	C	Kenloc™	•	•				C25
45° Lead Angle 	C	Kenclamp™	•	•	•			C8
		Kenlever™	•	•	•			C17
		Screw-On	•	•	•			C47
	S	Kenloc	•	•	•			C29
		Kenclamp	•	•	•			C12
		Kenlever	•	•	•			C19
		Kendex™	•	•	•			C39
		Screw-On	•	•	•			C52–C53
		MTS	•	•	•			C70
	T	Kendex	•	•	•			C40
			R	Kenloc	•	•	•	
Kenclamp	•			•	•			C9
Fix-Perfect™	•			•	•			C23
Screw-On	•			•	•			C50–C51
MTS	•			•	•			C66

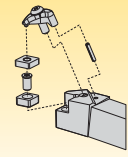
Clamping Styles

Kenclamp Style

- Uses Kenloc inserts.
- Unique clamp design provides rigid clamping.
- Ensures insert repeatability and seating.
- Reduced chatter and improved tool life.

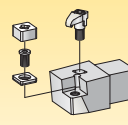

MTS Style Modular Tooling System

- Proven superior system in holding ceramic inserts rigidly in turning and profiling operations.
- Uses standard insert sizes — 80°, 75°, 55°, square, and trigon.
- This system offers the added versatility of using optional hardware to hold standard Kendex and Kenloc inserts.



Screw-On Style

- Top clamping by screw for Screw-On inserts.

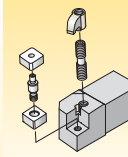

Kenloc Style

- Uses Kenloc inserts.
- Lock pin and top clamp provide rigid clamping.
- Wide variety of insert styles may be used.
- Tools may be used with or without clamp.



Kendex Style

- Uses Kendex inserts.
- Chipbreaker option available for ceramic inserts.
- Wide variety of insert styles may be used.

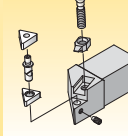

Wedglock™ Style

- Top and hole clamping for inserts with hole.

How Do Catalogue Numbers Work?

Each character in our catalogue number signifies a specific trait of that product. Use the following key columns and corresponding images to easily identify which attributes apply.



O.D./I.D. Tooling

M

Insert Holding Method

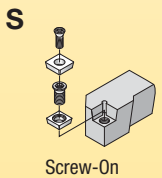
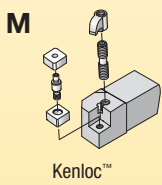
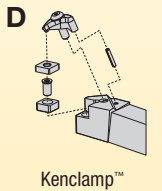
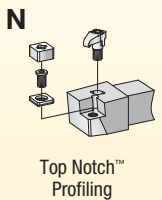
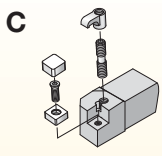

C

Insert Shape

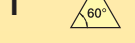
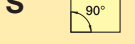
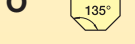
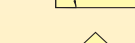
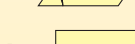
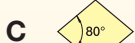
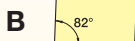

L

Tool Style or Lead Angle

N

Insert Clearance Angle

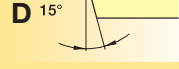
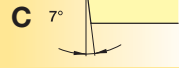
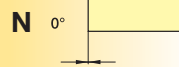

R

Hand of Tool

R = Right hand

L = Left hand

N = Neutral

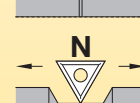
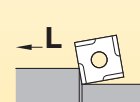

Additional Information

C = Deep pocket for ceramic insert

S = Single pocket locating wall

F = Straight shank, no offset

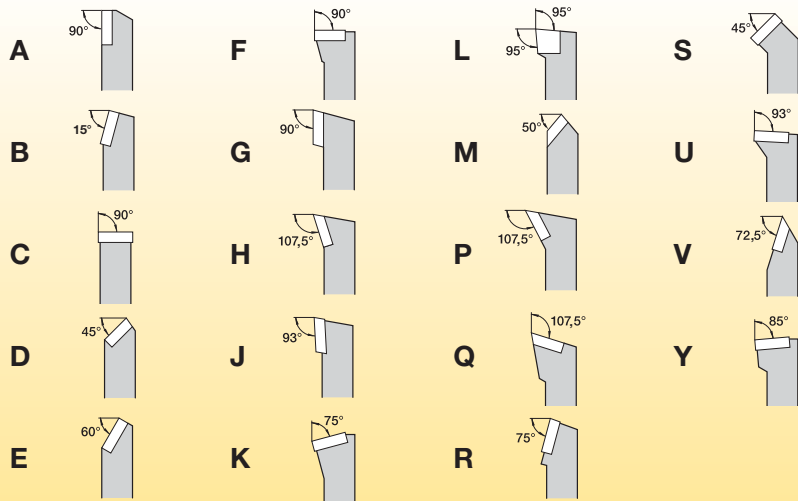

By referencing this easy-to-use guide, you can identify the correct product to meet your needs.



25

Shank Dimensions

25

Shank Dimensions

M

Tool Length

09

Insert Size

Additional Information

Insert Thickness (optional)

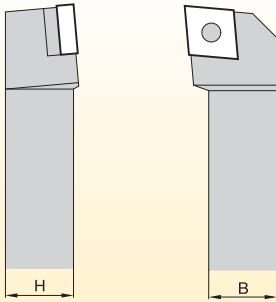

The 7th and 8th position shall be a significant two-digit number that indicates the holder cross section. If the dimension for the width "B" or the height "H" is represented by a one digit number, a 0 (zero) will be used in front of it. Example: 8mm = 08

L1	ISO
32	A
40	B
50	C
60	D
70	E
80	F
90	G
100	H
110	J
125	K
140	L
150	M
160	N
170	P
180	Q
200	R
250	S
300	T
350	U
400	V
450	W
500	Y
Special Design	X

KC =
Kenclamp™

H4 =
Wedglock™
clamping system

M =
MTS clamping
system for ceramic
and PCBN inserts

04 = 4,76mm
06 = 6,35mm

O.D./I.D. Tooling

Cutting Edge Length L10

H Hexagon
120°



O Octagon
135°



P Pentagon
108°



S Square
90°



T Triangular
60°



R Round
—



C Rhomboid
80°
D 55°
E 75°
M 86°
V 35°



W Trigon
80°
with enlarged
corner angles



L Rectangular
90°



A Parallelogram
85°
B 82°
K 55°

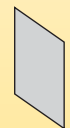

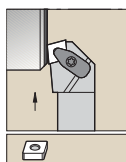

See pages B40–B49 and B174–B176 for inserts.

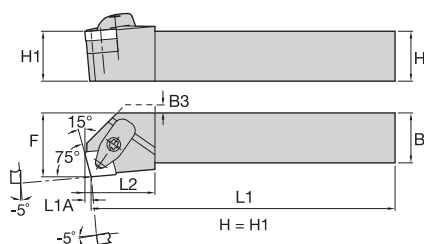

■ DCKN-KC 75°



catalogue number	H	B	F	L1	L2	L1A	B3	gage insert	shim	shim screw	Torx Plus	clamp assembly	Torx Plus	slotted pin	optional lock pin
right hand															
DCKNR2020K12KC04	20	20	25,0	125	32,0	3,1	6,0	CN..120408	ICSN433	KMSP415IP	15 IP	CM234R ASSY	15 IP	SSP025016M	KLM4615IP
DCKNR2525M12KC04	25	25	32,0	150	32,0	3,1	—	CN..120408	ICSN443	KMSP415IP	15 IP	CM234R ASSY	15 IP	SSP025016M	KLM4615IP
DCKNR3225P12KC04	32	25	32,0	170	32,0	3,1	—	CN..120408	ICSN443	KMSP415IP	15 IP	CM234R ASSY	15 IP	SSP025016M	KLM46L15IP
DCKNR3232P16KC06	32	32	40,0	170	32,0	3,8	—	CN..160612	ICSN543	KMSP515IP	15 IP	CM209R ASSY	15 IP	SSP025016M	KLM58L15IP
DCKNR3232P19KC06	32	32	40,0	170	38,0	4,6	—	CN..190612	ICSN643	KMSP625IP	25 IP	CM210R ASSY	25 IP	SSP025016M	KLM68L25IP
left hand															
DCKNL2020K12KC04	20	20	25,0	125	32,0	3,1	6,0	CN..120408	ICSN433	KMSP415IP	15 IP	CM234R ASSY	15 IP	SSP025016M	KLM4615IP
DCKNL2525M12KC04	25	25	32,0	150	32,0	3,1	—	CN..120408	ICSN443	KMSP415IP	15 IP	CM234R ASSY	15 IP	SSP025016M	KLM4615IP
DCKNL3225P12KC04	32	25	32,0	170	32,0	3,1	—	CN..120408	ICSN443	KMSP415IP	15 IP	CM234R ASSY	15 IP	SSP025016M	KLM46L15IP

O.D./I.D. Tooling

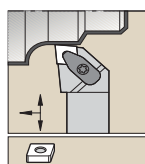

See pages B40–B49 and B174–B176 for inserts.

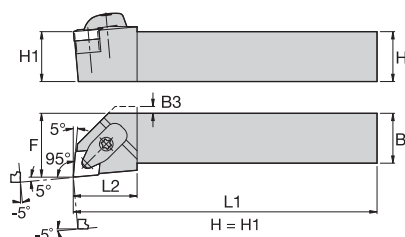

■ DCLN-KC 95°



catalogue number	H	B	F	L1	L2	B3	gage insert	shim	shim screw	Torx Plus	clamp assembly	Torx Plus	slotted pin	optional lock pin	
right hand															
DCLNR1616H09KC03	16	16	20,0	100	30,0	6,0	CN..090308	ICSN332	KMSP315IP	15 IP	CM234R ASSY	15 IP	SSP025016M	KLM34L9IP	
DCLNR2020K09KC03	20	20	25,0	125	30,0	2,0	CN..090308	ICSN332	KMSP315IP	15 IP	CM234R ASSY	15 IP	SSP025016M	KLM34L9IP	
DCLNR2020K12KC04	20	20	25,0	125	32,0	4,0	CN..120408	ICSN433	KMSP415IP	15 IP	CM234R ASSY	15 IP	SSP025016M	KLM4615IP	
DCLNR2525M12KC04	25	25	32,0	150	32,0	—	CN..120408	ICSN443	KMSP415IP	15 IP	CM234R ASSY	15 IP	SSP025016M	KLM46L15IP	
DCLNR2525M16KC06	25	25	32,0	150	33,0	—	CN..160612	ICSN543	KMSP515IP	15 IP	CM209R ASSY	15 IP	SSP025016M	KLM58L15IP	
DCCLNR3225P12KC04	32	25	32,0	170	32,0	—	CN..120408	ICSN443	KMSP415IP	15 IP	CM234R ASSY	15 IP	SSP025016M	KLM46L15IP	
DCCLNR3225P16KC06	32	25	32,0	170	33,0	—	CN..160612	ICSN543	KMSP515IP	15 IP	CM209R ASSY	15 IP	SSP025016M	KLM58L15IP	
DCCLNR3232P16KC06	32	32	40,0	170	33,0	—	CN..160612	ICSN543	KMSP515IP	15 IP	CM209R ASSY	15 IP	SSP025016M	KLM58L15IP	
DCCLNR3232P19KC06	32	32	40,0	170	40,0	—	CN..190612	ICSN643	KMSP625IP	25 IP	CM210R ASSY	25 IP	SSP025016M	KLM68L25IP	
DCLNR4040S19KC06	40	40	50,0	250	40,0	—	CN..190612	ICSN643	KMSP625IP	25 IP	CM210R ASSY	25 IP	SSP025016M	KLM68L25IP	
DCLNR4040S25KC09	40	40	50,0	250	51,0	—	CN..250924	ICSN846	KMSP825IP	25 IP	CM236R ASSY	25 IP	SSP025018M	KLM81025IP	

(continued)

(DCLN-KC 95° continued)

catalogue number	H B F L1 L2 B3	gage insert										
			shim	shim screw	Torx Plus	clamp assembly	Torx Plus	slotted pin	optional lock pin			
left hand												
DCLNL1616H09KC03	16 16 20,0 100 30,0 6,0	CN..090308	ICSN332	KMSP315IP	15 IP	CM234R ASSY	15 IP	SSP025016M	KLM34L9IP			
DCLNL2020K09KC03	20 20 25,0 125 30,0 2,0	CN..090308	ICSN332	KMSP315IP	15 IP	CM234R ASSY	15 IP	SSP025016M	KLM34L9IP			
DCLNL2020K12KC04	20 20 25,0 125 32,0 4,0	CN..120408	ICSN433	KMSP415IP	15 IP	CM234R ASSY	15 IP	SSP025016M	KLM4615IP			
DCLNL2525M12KC04	25 25 32,0 150 32,0 —	CN..120408	ICSN443	KMSP415IP	15 IP	CM234R ASSY	15 IP	SSP025016M	KLM46L15IP			
DCLNL2525M16KC06	25 25 32,0 150 33,0 —	CN..160612	ICSN543	KMSP515IP	15 IP	CM209R ASSY	15 IP	SSP025016M	KLM58L15IP			
DCLNL3225P12KC04	32 25 32,0 170 32,0 —	CN..120408	ICSN443	KMSP415IP	15 IP	CM234R ASSY	15 IP	SSP025016M	KLM46L15IP			
DCLNL3225P16KC06	32 25 32,0 170 33,0 —	CN..160612	ICSN543	KMSP515IP	15 IP	CM209R ASSY	15 IP	SSP025016M	KLM58L15IP			
DCLNL3232P16KC06	32 32 40,0 170 33,0 —	CN..160612	ICSN543	KMSP515IP	15 IP	CM209R ASSY	15 IP	SSP025016M	KLM58L15IP			
DCLNL3232P19KC06	32 32 40,0 170 40,0 —	CN..190612	ICSN643	KMSP625IP	25 IP	CM210R ASSY	25 IP	SSP025016M	KLM68L25IP			
DCLNL4040S19KC06	40 40 50,0 250 40,0 —	CN..190612	ICSN643	KMSP625IP	25 IP	CM210R ASSY	25 IP	SSP025016M	KLM68L25IP			
DCLNL4040S25KC09	40 40 50,0 250 51,0 —	CN..250924	ICSN846	KMSP825IP	25 IP	CM236R ASSY	25 IP	SSP025018M	KLM81025IP			

O.D./I.D. Tooling

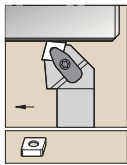

See pages B40–B49 and B174–B176 for inserts.

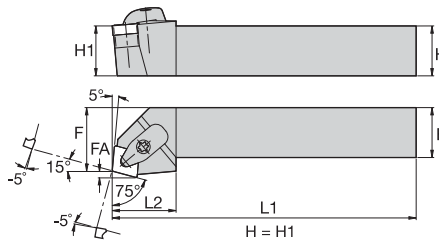
DCRN-KC 75°

catalogue number	H B F L1 L2 FA	gage inset										
			shim	shim screw	Torx Plus	clamp assembly	Torx Plus	slotted pin	optional lock pin			
right hand												
DCRNR2020K12KC04	20 20 25,0 125 32,0 3,1	CN..120406	ICSN433	KMSP415IP	15 IP	CM234R ASSY	15 IP	SSP025016M	KLM4615IP			
DCRNR2525M12KC04	25 25 32,0 150 32,0 3,1	CN..120406	ICSN443	KMSP415IP	15 IP	CM234R ASSY	15 IP	SSP025016M	KLM46L15IP			
DCRNR3225P12KC04	32 25 32,0 170 32,0 3,1	CN..120408	ICSN443	KMSP415IP	15 IP	CM234R ASSY	15 IP	SSP025016M	KLM46L15IP			
DCRNR3232P16KC06	32 32 40,0 170 38,0 3,8	CN..160612	ICSN543	KMSP515IP	15 IP	CM209R ASSY	15 IP	SSP025016M	KLM58L15IP			
DCRNR3232P19KC06	32 32 40,0 170 38,0 4,6	CN..190612	ICSN643	KMSP625IP	25 IP	CM210R ASSY	25 IP	SSP025016M	KLM68L25IP			
left hand												
DCRNL2020K12KC04	20 20 25,0 125 32,0 3,1	CN..120406	ICSN433	KMSP415IP	15 IP	CM234R ASSY	15 IP	SSP025016M	KLM4615IP			
DCRNL2525M12KC04	25 25 32,0 150 32,0 3,1	CN..120406	ICSN443	KMSP415IP	15 IP	CM234R ASSY	15 IP	SSP025016M	KLM46L15IP			
DCRNL3225P12KC04	32 25 32,0 170 32,0 3,1	CN..120408	ICSN443	KMSP415IP	15 IP	CM234R ASSY	15 IP	SSP025016M	KLM46L15IP			
DCRNL3232P16KC06	32 32 40,0 170 38,0 3,8	CN..160612	ICSN543	KMSP515IP	15 IP	CM209R ASSY	15 IP	SSP025016M	KLM58L15IP			

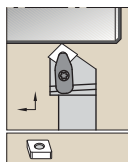

See pages B40–B49 and B174–B176 for inserts.

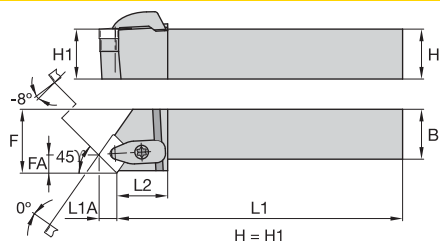

DCSN-KC 45°



O.D./I.D. Tooling

catalogue number	H	B	F	L1	L2	FA	L1A	gage insert	shim	shim screw	Torx Plus	clamp assembly	Torx Plus	slotted pin	optional lock pin
right hand															
DCSNR2020K12KC04	20	20	25,0	125	35,0	8,5	8,5	CN..120408	ICSN433	KMSP415IP	15 IP	CM234R ASSY	15 IP	SSP025016M	KLM4615IP
DCSNR2525M12KC04	25	25	32,0	150	35,0	8,5	8,5	CN..120408	ICSN443	KMSP415IP	15 IP	CM234R ASSY	15 IP	SSP025016M	KLM46L15IP
left hand															
DCSNL2020K12KC04	20	20	25,0	125	35,0	8,5	8,5	CN..120408	ICSN433	KMSP415IP	15 IP	CM234R ASSY	15 IP	SSP025016M	KLM4615IP
DCSNL2525M12KC04	25	25	32,0	150	35,0	8,5	8,5	CN..120408	ICSN443	KMSP415IP	15 IP	CM234R ASSY	15 IP	SSP025016M	KLM46L15IP

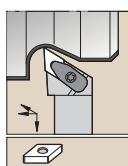

See pages B50–B58 and B176–B178 for inserts.

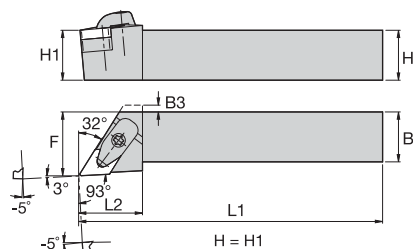

DDJN-KC 93°



catalogue number	H	B	F	L1	L2	B3	gage insert	shim	shim screw	Torx Plus	clamp assembly	Torx Plus	slotted pin	optional lock pin	
right hand															
DDJNR2020K11KC04	20	20	25,0	125	30,0	2,0	DN..110408	IDSN322	KMSP315IP	15 IP	CM234R ASSY	15 IP	SSP025016M	KLM34L9IP	
DDJNR2020K15KC06	20	20	25,0	125	32,0	4,0	DN..150608	IDSN433	KMSP415IP	15 IP	CM234R ASSY	15 IP	SSP025016M	KLM46L15IP	
DDJNR2525M11KC04	25	25	32,0	150	30,0	—	DN..110408	IDSN322	KMSP315IP	15 IP	CM234R ASSY	15 IP	SSP025016M	KLM34L9IP	
DDJNR2525M15KC06	25	25	32,0	150	32,0	—	DN..150608	IDSN433	KMSP415IP	15 IP	CM234R ASSY	15 IP	SSP025016M	KLM46L15IP	
DDJNR3225P15KC06	32	25	32,0	170	32,0	—	DN..150608	IDSN433	KMSP415IP	15 IP	CM234R ASSY	15 IP	SSP025016M	KLM46L15IP	
DDJNR3232P15KC06	32	32	40,0	170	32,0	—	DN..150608	IDSN433	KMSP415IP	15 IP	CM234R ASSY	15 IP	SSP025016M	KLM46L15IP	
left hand															
DDJNL2020K11KC04	20	20	25,0	125	30,0	2,0	DN..110408	IDSN322	KMSP315IP	15 IP	CM234R ASSY	15 IP	SSP025016M	KLM34L9IP	
DDJNL2020K15KC06	20	20	25,0	125	32,0	4,0	DN..150608	IDSN433	KMSP415IP	15 IP	CM234R ASSY	15 IP	SSP025016M	KLM46L15IP	
DDJNL2525M11KC04	25	25	32,0	150	30,0	—	DN..110408	IDSN322	KMSP315IP	15 IP	CM234R ASSY	15 IP	SSP025016M	KLM34L9IP	
DDJNL2525M15KC06	25	25	32,0	150	32,0	—	DN..150608	IDSN433	KMSP415IP	15 IP	CM234R ASSY	15 IP	SSP025016M	KLM46L15IP	
DDJNL3225P15KC06	32	25	32,0	170	32,0	—	DN..150608	IDSN433	KMSP415IP	15 IP	CM234R ASSY	15 IP	SSP025016M	KLM46L15IP	
DDJNL3232P15KC06	32	32	40,0	170	32,0	—	DN..150608	IDSN433	KMSP415IP	15 IP	CM234R ASSY	15 IP	SSP025016M	KLM46L15IP	

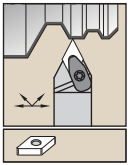

See pages B50–B58 and B176–B178 for inserts.

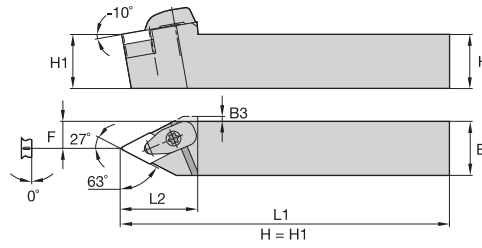

■ **DDNN-KC 63°**



catalogue number	H	B	F	L1	L2	B3	gage insert	shim	shim screw	Torx Plus	clamp assembly	Torx Plus	slotted pin	optional lock pin
right hand														
DDNNR2020K15KC06	20	20	10,0	125	40,0	2,5	DN..150608	IDSN433	KMSP415IP	15 IP	CM234R ASSY	15 IP	SSP025016M	KLM46L15IP
DDNNR2525M15KC06	25	25	12,5	150	40,0	—	DN..150608	IDSN433	KMSP415IP	15 IP	CM234R ASSY	15 IP	SSP025016M	KLM46L15IP
left hand														
DDNNL2020K15KC06	20	20	10,0	125	40,0	2,5	DN..150608	IDSN433	KMSP415IP	15 IP	CM234R ASSY	15 IP	SSP025016M	KLM46L15IP
DDNNL2525M15KC06	25	25	12,5	150	40,0	—	DN..150608	IDSN433	KMSP415IP	15 IP	CM234R ASSY	15 IP	SSP025016M	KLM46L15IP
DDNNL3225P15KC06	32	25	12,5	170	40,0	—	DN..150608	IDSN433	KMSP415IP	15 IP	CM234R ASSY	15 IP	SSP025016M	KLM46L15IP

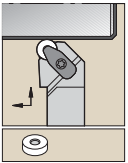

See pages B58–B59 for inserts.

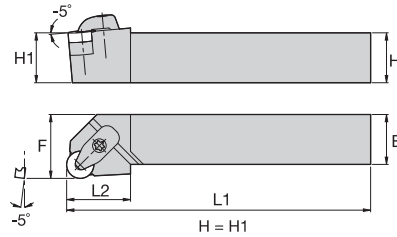

■ **DRGN-KC**



catalogue number	H	B	F	L1	L2	gage insert	shim	shim screw	Torx Plus	clamp assembly	Torx Plus	slotted pin	optional lock pin	
right hand														
DRGNR2525M12KC04	25	25	32,0	150	32,0	RN..120400	IRSN44	KMSP415IP	15 IP	CM234R ASSY	15 IP	SSP025016M	KLM46L15IP	
DRGNR3225P12KC04	32	25	32,0	170	32,0	RN..120400	IRSN44	KMSP415IP	15 IP	CM234R ASSY	15 IP	SSP025016M	KLM46L15IP	
DRGNR4040S25KC09	40	40	50,0	250	48,0	RN..250900	IRSN84	KMSP825IP	25 IP	CM236R ASSY	25 IP	SSP025018M	KLM81025IP	
left hand														
DRGNL3225P12KC04	32	25	32,0	170	32,0	RN..120400	IRSN44	KMSP415IP	15 IP	CM234R ASSY	15 IP	SSP025016M	KLM46L15IP	
DRGNL3232P15KC06	32	32	40,0	170	32,0	RN..150600	IRSN54	KMSP515IP	15 IP	CM209R ASSY	15 IP	SSP025016M	KLM58L15IP	
DRGNL4040S25KC09	40	40	50,0	250	48,0	RN..250900	IRSN84	KMSP825IP	25 IP	CM236R ASSY	25 IP	SSP025018M	KLM81025IP	

O.D./I.D. Tooling

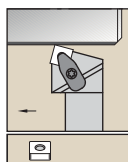

See pages B59–B66 and B178–B179 for inserts.

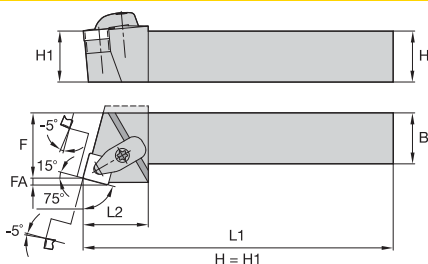

DSBN-KC 75°

O.D./I.D. Tooling



catalogue number	H	B	F	L1	L2	FA	gage insert	shim	shim screw	Torx Plus	clamp assembly	Torx Plus	slotted pin	optional lock pin	
right hand															
DSBNR4040S25KC09	40	40	35,0	250	52,0	5,9	SN..250924	ISSN846	KMSP825IP	25 IP	CM236R ASSY	25 IP	SSP025018M	KLM81025IP	
left hand															
DSBNL2525M12KC04	25	25	22,0	150	32,0	3,0	SN..120408	ISSN443	KMSP415IP	15 IP	CM234R ASSY	15 IP	SSP025016M	KLM46L15IP	
DSBNL3232P15KC06	32	32	27,0	170	36,0	5,0	SN..150612	ISSN543	KMSP515IP	15 IP	CM209R ASSY	15 IP	SSP025016M	KLM58L15IP	
DSBNL4040S25KC09	40	40	35,0	250	52,0	5,9	SN..250924	ISSN846	KMSP825IP	25 IP	CM236R ASSY	25 IP	SSP025018M	KLM81025IP	

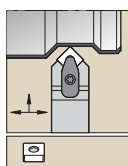

See pages B59–B66 and B178–B179 for inserts.

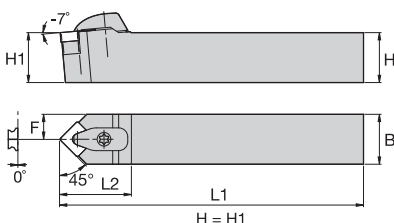

DSDN-KC 45°



catalogue number	H	B	F	L1	L2	gage insert	shim	shim screw	Torx Plus	clamp assembly	Torx Plus	slotted pin	optional lock pin
DSDNN2020K12KC04	20	20	10,0	125	36,0	SN..120408	ISSN433	KMSP415IP	15 IP	CM234R ASSY	15 IP	SSP025016M	KLM46L15IP
DSDNN2525M12KC04	25	25	12,5	150	36,0	SN..120408	ISSN443	KMSP415IP	15 IP	CM234R ASSY	15 IP	SSP025016M	KLM46L15IP
DSDNN2525M15KC06	25	25	12,5	150	42,0	SN..150612	ISSN543	KMSP515IP	15 IP	CM209R ASSY	15 IP	SSP025016M	KLM58L15IP
DSDNN3225P12KC04	32	25	12,0	170	36,0	SN..120408	ISSN443	KMSP415IP	15 IP	CM234R ASSY	15 IP	SSP025016M	KLM46L15IP
DSDNN3232P19KC06	32	32	15,5	170	44,0	SN..190612	ISSN643	KMSP625IP	25 IP	CM210R ASSY	25 IP	SSP025016M	KLM68L25IP
DSDNN4040S25KC09	40	40	19,5	250	59,0	SN..250924	ISSN846	KMSP825IP	25 IP	CM236R ASSY	25 IP	SSP025018M	KLM81025IP

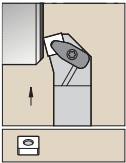

See pages B59–B66 and B178–B179 for inserts.

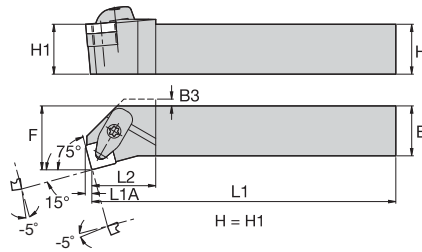

■ **DSKN-KC 75°**



catalogue number	H	B	F	L1	L2	L1A	B3	gage insert	shim	shim screw	Torx Plus	clamp assembly	Torx Plus	slotted pin	optional lock pin	
right hand																
DSKNR2020K12KC04	20	20	25,0	125	32,0	3,1	8,0	SN..120408	ISSN433	KMSP415IP	15 IP	CM234R ASSY	15 IP	SSP025016M	KLM4615IP	
DSKNR2525M12KC04	25	25	32,0	150	32,0	3,1	4,0	SN..120408	ISSN443	KMSP415IP	15 IP	CM234R ASSY	15 IP	SSP025016M	KLM46L15IP	
DSKNR3225P12KC04	32	25	32,0	170	32,0	3,1	—	SN..120408	ISSN443	KMSP415IP	15 IP	CM234R ASSY	15 IP	SSP025016M	KLM46L15IP	
DSKNR3232P15KC06	32	32	40,0	170	32,0	3,8	—	SN..150612	ISSN543	KMSP515IP	15 IP	CM209R ASSY	15 IP	SSP025016M	KLM58L15IP	
DSKNR3232P19KC06	32	32	40,0	170	38,0	4,6	—	SN..190612	ISSN643	KMSP625IP	25 IP	CM210R ASSY	25 IP	SSP025016M	KLM68L25IP	
left hand																
DSKNL2525M12KC04	25	25	32,0	150	32,0	3,1	4,0	SN..120408	ISSN443	KMSP415IP	15 IP	CM234R ASSY	15 IP	SSP025016M	KLM46L15IP	
DSKNL3225P12KC04	32	25	32,0	170	32,0	3,1	—	SN..120408	ISSN443	KMSP415IP	15 IP	CM234R ASSY	15 IP	SSP025016M	KLM46L15IP	
DSKNL3232P15KC06	32	32	40,0	170	32,0	3,8	—	SN..150612	ISSN543	KMSP515IP	15 IP	CM209R ASSY	15 IP	SSP025016M	KLM58L15IP	

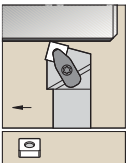

See pages B59–B66 and B178–B179 for inserts.

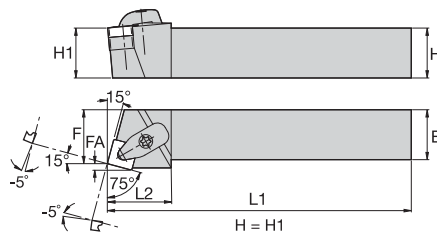

■ **DSRN-KC 75°**



catalogue number	H	B	F	L1	L2	FA	gage insert	shim	shim screw	Torx Plus	clamp assembly	Torx Plus	slotted pin	optional lock pin		
right hand																
DSRNR2020K12KC04	20	20	22,0	125	32,0	3,1	SN..120408	ISSN433	KMSP415IP	15 IP	CM234R ASSY	15 IP	SSP025016M	KLM4615IP		
DSRNR2525M12KC04	25	25	27,0	150	32,0	3,1	SN..120408	ISSN443	KMSP415IP	15 IP	CM234R ASSY	15 IP	SSP025016M	KLM46L15IP		
DSRNR3232P15KC06	32	32	35,0	170	38,0	3,8	SN..150612	ISSN543	KMSP515IP	15 IP	CM209R ASSY	15 IP	SSP025016M	KLM58L15IP		
DSRNR3232P19KC06	32	32	35,0	170	42,0	4,6	SN..190612	ISSN643	KMSP625IP	25 IP	CM210R ASSY	25 IP	SSP025016M	KLM68L25IP		
DSRNR4040S25KC09	40	40	43,0	250	52,0	5,9	SN..250924	ISSN846	KMSP825IP	25 IP	CM236R ASSY	25 IP	SSP025018M	KLM81025IP		
left hand																
DSRNL2525M12KC04	25	25	27,0	150	32,0	3,1	SN..120408	ISSN443	KMSP415IP	15 IP	CM234R ASSY	15 IP	SSP025016M	KLM46L15IP		
DSRNL3232P15KC06	32	32	35,0	170	38,0	3,8	SN..150612	ISSN543	KMSP515IP	15 IP	CM209R ASSY	15 IP	SSP025016M	KLM58L15IP		
DSRNL4040S25KC09	40	40	43,0	250	52,0	5,9	SN..250924	ISSN846	KMSP825IP	25 IP	CM236R ASSY	25 IP	SSP025018M	KLM81025IP		

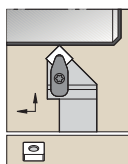

See pages B59–B66 and B178–B179 for inserts.

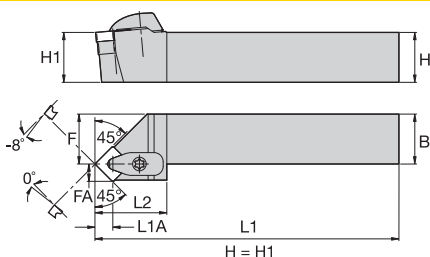

■ DSSN-KC 45°

O.D./I.D. Tooling



catalogue number	H	B	F	L1	L2	FA	L1A	gage insert	shim	shim screw	Torx Plus	clamp assembly	Torx Plus	slotted pin	optional lock pin
right hand															
DSSNR2020K12KC04	20	20	25,0	125	36,0	8,7	8,7	SN..120408	ISSN433	KMSP415IP	15 IP	CM234R ASSY	15 IP	SSP025016M	KLM4615IP
DSSNR2525M12KC04	25	25	32,0	150	36,0	8,7	8,7	SN..120408	ISSN443	KMSP415IP	15 IP	CM234R ASSY	15 IP	SSP025016M	KLM46L15IP
DSSNR2525M15KC06	25	25	32,0	150	42,0	10,7	10,7	SN..150612	ISSN543	KMSP515IP	15 IP	CM209R ASSY	15 IP	SSP025016M	KLM58L15IP
DSSNR3225P12KC04	32	25	32,0	170	35,4	8,7	8,7	SN..120408	ISSN443	KMSP415IP	15 IP	CM234R ASSY	15 IP	SSP025016M	KLM46L15IP
DSSNR3232P15KC06	32	32	40,0	170	40,3	10,7	10,7	SN..150612	ISSN543	KMSP515IP	15 IP	CM209R ASSY	15 IP	SSP025016M	KLM58L15IP
DSSNR3232P19KC06	32	32	40,0	170	44,0	10,7	10,7	SN..190612	ISSN643	KMSP625IP	25 IP	CM210R ASSY	25 IP	SSP025016M	KLM68L25IP
left hand															
DSSNL2020K12KC04	20	20	25,0	125	36,0	8,7	8,7	SN..120408	ISSN433	KMSP415IP	15 IP	CM234R ASSY	15 IP	SSP025016M	KLM4615IP
DSSNL2525M12KC04	25	25	32,0	150	36,0	8,7	8,7	SN..120408	ISSN443	KMSP415IP	15 IP	CM234R ASSY	15 IP	SSP025016M	KLM46L15IP
DSSNL3225P12KC04	32	25	32,0	170	35,4	8,7	8,7	SN..120408	ISSN443	KMSP415IP	15 IP	CM234R ASSY	15 IP	SSP025016M	KLM46L15IP
DSSNL3232P15KC06	32	32	40,0	170	40,3	10,7	10,7	SN..150612	ISSN543	KMSP515IP	15 IP	CM209R ASSY	15 IP	SSP025016M	KLM58L15IP
DSSNL3232P19KC06	32	32	40,0	170	44,0	10,7	10,7	SN..190612	ISSN643	KMSP625IP	25 IP	CM210R ASSY	25 IP	SSP025016M	KLM68L25IP

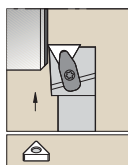

See pages B66–B73 and B179–B180 for inserts.

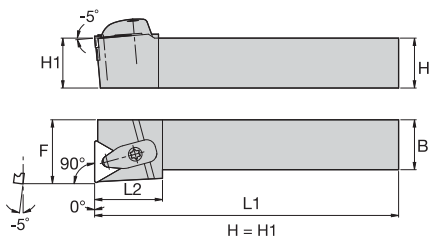

■ DTFN-KC 90°



catalogue number	H	B	F	L1	L2	gage insert	shim	shim screw	Torx Plus	clamp assembly	Torx Plus	slotted pin	optional lock pin
right hand													
DTFNR2020K16KC04	20	20	25,0	125	32,0	TN..160408	ITSN323	KMSP315IP	15 IP	CM234R ASSY	15 IP	SSP025016M	KLM34L9IP
DTFNR2525M16KC04	25	25	32,0	150	32,0	TN..160408	ITSN323	KMSP315IP	15 IP	CM234R ASSY	15 IP	SSP025016M	KLM34L9IP
DTFNR2525M22KC04	25	25	32,0	150	34,0	TN..220408	ITSN443	KMSP415IP	15 IP	CM234R ASSY	15 IP	SSP025016M	KLM46L15IP
DTFNR3232P27KC06	32	32	40,0	170	38,0	TN..270612	ITSN534	KMSP515IP	15 IP	CM209R ASSY	15 IP	SSP025016M	KLM58L15IP
left hand													
DTFNL2020K16KC04	20	20	25,0	125	32,0	TN..160408	ITSN323	KMSP315IP	15 IP	CM234R ASSY	15 IP	SSP025016M	KLM34L9IP
DTFNL2525M16KC04	25	25	32,0	150	32,0	TN..160408	ITSN323	KMSP315IP	15 IP	CM234R ASSY	15 IP	SSP025016M	KLM34L9IP
DTFNL2525M22KC04	25	25	32,0	150	34,0	TN..220408	ITSN443	KMSP415IP	15 IP	CM234R ASSY	15 IP	SSP025016M	KLM46L15IP
DTFNL3225P16KC04	32	25	32,0	170	32,0	TN..160408	ITSN323	KMSP315IP	15 IP	CM234R ASSY	15 IP	SSP025016M	KLM34L9IP
DTFNL3225P22KC04	32	25	32,0	170	34,0	TN..220408	ITSN443	KMSP415IP	15 IP	CM234R ASSY	15 IP	SSP025016M	KLM46L15IP

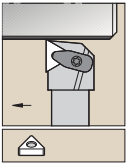

See pages B66–B73 and B179–B180 for inserts.

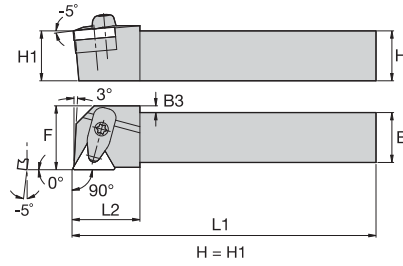
DTGN-KC 90°

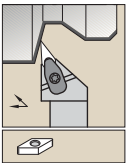

catalogue number	H	B	F	L1	L2	B3	gage insert	shim	shim screw	Torx Plus	clamp assembly	Torx Plus	slotted pin	optional lock pin	
right hand															
DTGNR2020K16KC04	20	20	25,0	125	25,0	6,5	TN..160408	ITSN323	KMSP315IP	15 IP	CM234R ASSY	15 IP	SSP025016M	KLM34L9IP	
DTGNR2525M16KC04	25	25	32,0	150	25,0	—	TN..160408	ITSN323	KMSP315IP	15 IP	CM234R ASSY	15 IP	SSP025016M	KLM34L9IP	
DTGNR2525M22KC04	25	25	32,0	150	32,0	3,0	TN..220408	ITSN443	KMSP415IP	15 IP	CM234R ASSY	15 IP	SSP025016M	KLM46L15IP	
left hand															
DTGNL2020K16KC04	20	20	25,0	125	25,0	6,5	TN..160408	ITSN323	KMSP315IP	15 IP	CM234R ASSY	15 IP	SSP025016M	KLM34L9IP	
DTGNL2525M16KC04	25	25	32,0	150	25,0	—	TN..160408	ITSN323	KMSP315IP	15 IP	CM234R ASSY	15 IP	SSP025016M	KLM34L9IP	

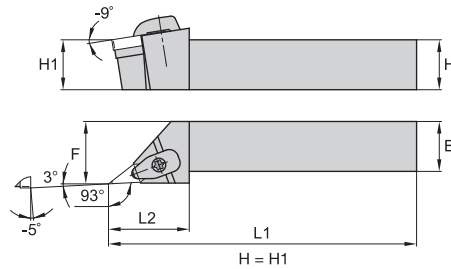

See pages B74–B78 and B180–B181 for inserts.

DVJN-KC 93°

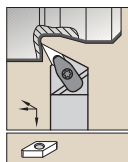
catalogue number	H	B	F	L1	L2	gage insert	shim	shim screw	Torx Plus	clamp assembly	Torx Plus	slotted pin	optional lock pin
right hand													
DVJNR2020K16KC04	20	20	25,0	125	46,0	VN..160408	IVSN322	KMSP315IP	15 IP	CM215R ASSY	15 IP	SSP025016M	KLM34L9IP
DVJNR2525M16KC04	25	25	32,0	150	46,0	VN..160408	IVSN322	KMSP315IP	15 IP	CM215R ASSY	15 IP	SSP025016M	KLM34L9IP
DVJNR2525M22KC04	25	25	32,0	150	55,0	VN..220408	IVSN432	KMSP415IP	15 IP	CM235R ASSY	15 IP	SSP025016M	KLM46L15IP
DVJNR3225P16KC04	32	25	32,0	170	46,0	VN..160408	IVSN322	KMSP315IP	15 IP	CM215R ASSY	15 IP	SSP025016M	KLM34L9IP
DVJNR3225P22KC04	32	25	32,0	170	55,0	VN..220408	IVSN432	KMSP415IP	15 IP	CM235R ASSY	15 IP	SSP025016M	KLM46L15IP
left hand													
DVJNL2020K16KC04	20	20	25,0	125	46,0	VN..160408	IVSN322	KMSP315IP	15 IP	CM215R ASSY	15 IP	SSP025016M	KLM34L9IP
DVJNL2525M16KC04	25	25	32,0	150	46,0	VN..160408	IVSN322	KMSP315IP	15 IP	CM215R ASSY	15 IP	SSP025016M	KLM34L9IP
DVJNL2525M22KC04	25	25	32,0	150	55,0	VN..220408	IVSN432	KMSP415IP	15 IP	CM235R ASSY	15 IP	SSP025016M	KLM46L15IP
DVJNL3225P16KC04	32	25	32,0	170	46,0	VN..160408	IVSN322	KMSP315IP	15 IP	CM215R ASSY	15 IP	SSP025016M	KLM34L9IP
DVJNL3225P22KC04	32	25	32,0	170	55,0	VN..220408	IVSN432	KMSP415IP	15 IP	CM235R ASSY	15 IP	SSP025016M	KLM46L15IP



See pages B74–B78 and B180–B181 for inserts.

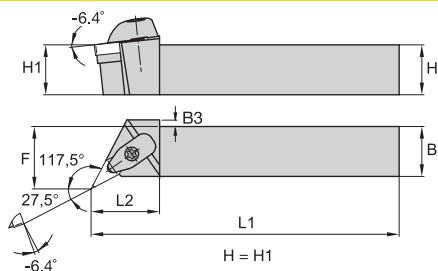

■ **DVON-KC 117,5°**



O.D./I.D. Tooling

catalogue number	H	B	F	L1	L2	B3	gage insert	shim	shim screw	Torx Plus	clamp assembly	Torx Plus	slotted pin	optional lock pin	
right hand															
DVONR2020K16KC04	20	20	27,0	125	38,0	5,0	VN..160408	IVSN322	KMSP315IP	15 IP	CM215R ASSY	15 IP	SSP025016M	KLM34L9IP	
DVONR2525M16KC04	25	25	32,0	150	38,0	—	VN..160408	IVSN322	KMSP315IP	15 IP	CM215R ASSY	15 IP	SSP025016M	KLM34L9IP	
DVONR3225P16KC04	32	25	32,0	170	38,0	—	VN..160408	IVSN322	KMSP315IP	15 IP	CM215R ASSY	15 IP	SSP025016M	KLM34L9IP	
left hand															
DVONL2020K16KC04	20	20	27,0	125	38,0	5,0	VN..160408	IVSN322	KMSP315IP	15 IP	CM215R ASSY	15 IP	SSP025016M	KLM34L9IP	
DVONL2525M16KC04	25	25	32,0	150	38,0	—	VN..160408	IVSN322	KMSP315IP	15 IP	CM215R ASSY	15 IP	SSP025016M	KLM34L9IP	
DVONL3225P16KC04	32	25	32,0	170	38,0	—	VN..160408	IVSN322	KMSP315IP	15 IP	CM215R ASSY	15 IP	SSP025016M	KLM34L9IP	

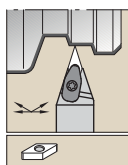

See pages B74–B78 and B180–B181 for inserts.

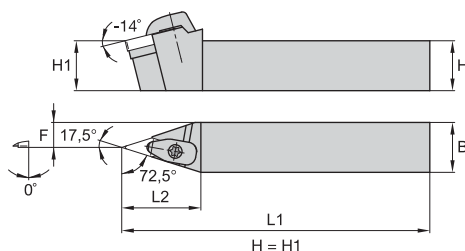

■ **DVVN-KC 72,5°**



catalogue number	H	B	F	L1	L2	gage insert	shim	shim screw	Torx Plus	clamp assembly	Torx Plus	slotted pin	optional lock pin
DVVNN2020K16KC04	20	20	9,5	125	48,0	VN..160408	IVSN322	KMSP315IP	15 IP	CM215R ASSY	15 IP	SSP025016M	KLM34L9IP
DVVNN2525M16KC04	25	25	12,0	150	48,0	VN..160408	IVSN322	KMSP315IP	15 IP	CM215R ASSY	15 IP	SSP025016M	KLM34L9IP
DVVNN2525M22KC04	25	25	12,0	150	57,0	VN..220408	IVSN432	KMSP415IP	15 IP	CM235R ASSY	15 IP	SSP025016M	KLM4615IP
DVVNN3225P16KC04	32	25	12,0	170	48,0	VN..160408	IVSN322	KMSP315IP	15 IP	CM215R ASSY	15 IP	SSP025016M	KLM34L9IP

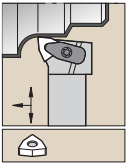

See pages B79–B83 and B181 for inserts.

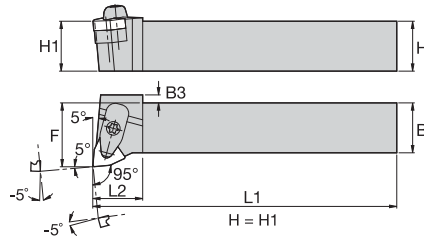

■ **DWLN-KC 95°**



catalogue number	H	B	F	L1	L2	B3	gage insert	shim	shim screw	Torx Plus	clamp assembly	Torx Plus	slotted pin	optional lock pin	
right hand															
DWLN2020K06KC04	20	20	25,0	125	31,0	—	WN..060408	IWSN322	KMSP315IP	15 IP	CM234R ASSY	15 IP	SSP025016M	KLM34L9IP	
DWLN2020K08KC04	20	20	25,0	125	33,0	—	WN..080408	IWSN433	KMSP415IP	15 IP	CM234R ASSY	15 IP	SSP025016M	KLM4615IP	
DWLN2525M06KC04	25	25	32,0	150	25,0	—	WN..060408	IWSN322	KMSP315IP	15 IP	CM234R ASSY	15 IP	SSP025016M	KLM34L9IP	
DWLN2525M08KC04	25	25	32,0	150	25,0	4,0	WN..080408	IWSN433	KMSP415IP	15 IP	CM234R ASSY	15 IP	SSP025016M	KLM4615IP	
DWLN3225P08KC04	32	25	32,0	170	25,0	4,0	WN..080408	IWSN433	KMSP415IP	15 IP	CM234R ASSY	15 IP	SSP025016M	KLM4615IP	
DWLN3232P08KC04	32	32	40,0	170	25,0	—	WN..080408	IWSN433	KMSP415IP	15 IP	CM234R ASSY	15 IP	SSP025016M	KLM4615IP	
left hand															
DWLN2020K06KC04	20	20	25,0	125	31,0	—	WN..060408	IWSN322	KMSP315IP	15 IP	CM234R ASSY	15 IP	SSP025016M	KLM34L9IP	
DWLN2020K08KC04	20	20	25,0	125	33,0	—	WN..080408	IWSN433	KMSP415IP	15 IP	CM234R ASSY	15 IP	SSP025016M	KLM4615IP	
DWLN2525M06KC04	25	25	32,0	150	25,0	—	WN..060408	IWSN322	KMSP315IP	15 IP	CM234R ASSY	15 IP	SSP025016M	KLM34L9IP	
DWLN2525M08KC04	25	25	32,0	150	25,0	4,0	WN..080408	IWSN433	KMSP415IP	15 IP	CM234R ASSY	15 IP	SSP025016M	KLM4615IP	
DWLN3225P08KC04	32	25	32,0	170	25,0	4,0	WN..080408	IWSN433	KMSP415IP	15 IP	CM234R ASSY	15 IP	SSP025016M	KLM4615IP	
DWLN3232P08KC04	32	32	40,0	170	25,0	—	WN..080408	IWSN433	KMSP415IP	15 IP	CM234R ASSY	15 IP	SSP025016M	KLM4615IP	

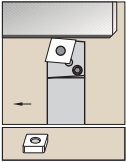

See pages B40–B49 and B174–B176 for inserts.

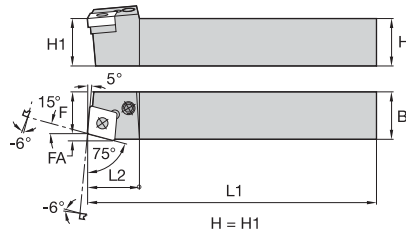

■ **PCBN 75°**



catalogue number	H	B	F	L1	L2	FA	gage insert	shim	shim pin	punch pin	lever	lever screw	Torx Plus
right hand													
PCBNR2525M12	25	25	22,0	150	26,0	3,1	CN..120408	512.112	513.023	515.018	511.023	514.123	15 IP
PCBNR2525M16	25	25	22,0	150	28,0	4,2	CN..160612	512.117	513.025	515.022	511.025	514.125	15 IP
PCBNR3225P12	32	25	22,0	170	28,0	3,1	CN..120408	512.112	513.023	515.018	511.023	514.123	15 IP
PCBNR3225P16	32	25	22,0	170	28,0	4,2	CN..160612	512.117	513.025	515.022	511.025	514.125	15 IP
PCBNR3232P16	32	32	27,0	170	38,0	4,2	CN..160612	512.117	513.025	515.022	511.025	514.125	15 IP
PCBNR3232P19	32	32	27,0	170	40,0	4,6	CN..190612	512.123	513.033	515.022	511.033	514.133	25 IP
PCBNR4040S19	40	40	35,0	250	38,0	4,6	CN..190612	512.123	513.033	515.022	511.033	514.133	25 IP
left hand													
PCBNL2020K12	20	20	17,0	125	26,0	3,1	CN..120408	512.112	513.023	515.018	511.023	514.123	15 IP
PCBNL2525M12	25	25	22,0	150	26,0	3,1	CN..120408	512.112	513.023	515.018	511.023	514.123	15 IP
PCBNL2525M16	25	25	22,0	150	28,0	4,2	CN..160612	512.117	513.025	515.022	511.025	514.125	15 IP
PCBNL3225P16	32	25	22,0	170	28,0	4,2	CN..160612	512.117	513.025	515.022	511.025	514.125	15 IP
PCBNL3232P16	32	32	27,0	170	38,0	4,2	CN..160612	512.117	513.025	515.022	511.025	514.125	15 IP
PCBNL3232P19	32	32	27,0	170	40,0	4,6	CN..190612	512.123	513.033	515.022	511.033	514.133	25 IP
PCBNL4040S19	40	40	35,0	250	38,0	4,6	CN..190612	512.123	513.033	515.022	511.033	514.133	25 IP

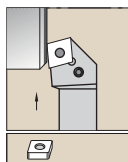

See pages B40–B49 and B174–B176 for inserts.

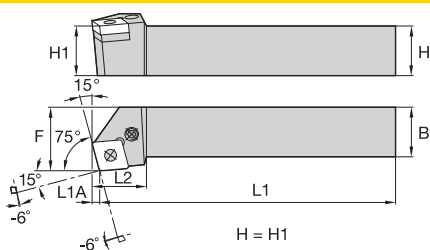

■ PCKN 75°

O.D./I.D. Tooling



catalogue number	H	B	F	L1	L2	L1A	gage insert	shim	shim pin	punch pin	lever	lever screw	Torx Plus
right hand													
PCKNR2020K12	20	20	25,0	125	23,0	3,09	CN..120408	512.112	513.023	515.018	511.023	514.123	15 IP
PCKNR2525M12	25	25	32,0	150	23,0	3,09	CN..120408	512.112	513.023	515.018	511.023	514.123	15 IP
PCKNR2525M16	25	25	32,0	150	30,0	3,80	CN..160612	512.117	513.025	515.022	511.025	514.125	15 IP
PCKNR3225P12	32	25	32,0	170	26,0	3,09	CN..120408	512.112	513.023	515.018	511.023	514.123	15 IP
PCKNR3225P16	32	25	32,0	170	30,0	3,80	CN..160612	512.117	513.025	515.022	511.025	514.125	15 IP
PCKNR3232P19	32	32	40,0	170	40,0	4,63	CN..190612	512.123	513.033	515.022	511.033	514.133	25 IP
left hand													
PCKNL2020K12	20	20	25,0	125	23,0	3,09	CN..120408	512.112	513.023	515.018	511.023	514.123	15 IP
PCKNL2525M12	25	25	32,0	150	23,0	3,09	CN..120408	512.112	513.023	515.018	511.023	514.123	15 IP
PCKNL3225P12	32	25	32,0	170	26,0	3,09	CN..120408	512.112	513.023	515.018	511.023	514.123	15 IP
PCKNL3225P16	32	25	32,0	170	30,0	3,80	CN..160612	512.117	513.025	515.022	511.025	514.125	15 IP
PCKNL3232P19	32	32	40,0	170	40,0	4,63	CN..190612	512.123	513.033	515.022	511.033	514.133	25 IP

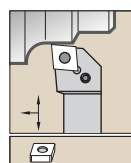

See pages B40–B49 and B174–B176 for inserts.

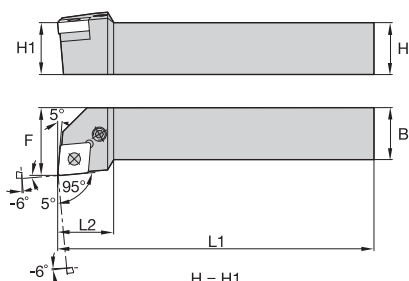

■ PCLN 95°



catalogue number	H	B	F	L1	L2	gage insert	shim	shim pin	punch pin	lever	lever screw	Torx Plus
right hand												
PCLNR1616H12	16	16	20,0	100	26,0	CN..120408	512.112	513.023	515.018	511.023	514.123	15 IP
PCLNR2020K12	20	20	25,0	125	26,0	CN..120408	512.112	513.023	515.018	511.023	514.123	15 IP
PCLNR2525M12	25	25	32,0	150	26,0	CN..120408	512.112	513.023	515.018	511.023	514.123	15 IP
PCLNR2525M16	25	25	32,0	150	28,0	CN..160612	512.117	513.025	515.022	511.025	514.125	15 IP
PCLNR2525M19	25	25	32,0	150	36,0	CN..190612	512.123	513.033	515.022	511.033	514.133	25 IP
PCLNR3225P12	32	25	32,0	170	26,0	CN..120408	512.112	513.023	515.018	511.023	514.123	15 IP
PCLNR3225P16	32	25	32,0	170	38,0	CN..160612	512.117	513.025	515.022	511.025	514.125	15 IP
PCLNR3225P19	32	25	32,0	170	38,0	CN..190612	512.123	513.033	515.022	511.033	514.133	25 IP
PCLNR3232P16	32	32	40,0	170	36,0	CN..160612	512.117	513.025	515.022	511.025	514.125	15 IP
PCLNR3232P19	32	32	40,0	170	36,0	CN..190612	512.123	513.033	515.022	511.033	514.133	25 IP
PCLNR4040S19	40	40	50,0	250	36,0	CN..190612	512.123	513.033	515.022	511.033	514.133	25 IP

(continued)

(PCLN 95° continued)

catalogue number	H	B	F	L1	L2	gage insert						Torx Plus
							shim	shim pin	punch pin	lever	lever screw	
left hand												
PCLNL1616H12	16	16	20,0	100	26,0	CN..120408	512.112	513.023	515.018	511.023	514.123	15 IP
PCLNL2020K12	20	20	25,0	125	26,0	CN..120408	512.112	513.023	515.018	511.023	514.123	15 IP
PCLNL2525M12	25	25	32,0	150	26,0	CN..120408	512.112	513.023	515.018	511.023	514.123	15 IP
PCLNL2525M16	25	25	32,0	150	28,0	CN..160612	512.117	513.025	515.022	511.025	514.125	15 IP
PCLNL2525M19	25	25	32,0	150	36,0	CN..190612	512.123	513.033	515.022	511.033	514.133	25 IP
PCLNL3225P12	32	25	32,0	170	26,0	CN..120408	512.112	513.023	515.018	511.023	514.123	15 IP
PCLNL3225P16	32	25	32,0	170	38,0	CN..160612	512.117	513.025	515.022	511.025	514.125	15 IP
PCLNL3225P19	32	25	32,0	170	38,0	CN..190612	512.123	513.033	515.022	511.033	514.133	25 IP
PCLNL3232P16	32	32	40,0	170	36,0	CN..160612	512.117	513.025	515.022	511.025	514.125	15 IP
PCLNL3232P19	32	32	40,0	170	36,0	CN..190612	512.123	513.033	515.022	511.033	514.133	25 IP
PCLNL4040S19	40	40	50,0	250	36,0	CN..190612	512.123	513.033	515.022	511.033	514.133	25 IP

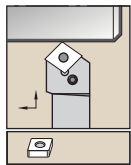

See pages B40–B49 and B174–B176 for inserts.

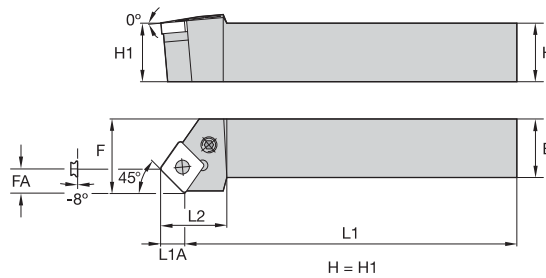
■ PCSN 45°

catalogue number	H	B	F	L1	L2	FA	L1A	gage insert						Torx Plus
									shim	shim pin	punch pin	lever	lever screw	
right hand														
PCSNR2020K12	20	20	25,0	125	26,0	8,5	8,5	CN..120408	512.112	513.023	515.018	511.023	514.123	15 IP
PCSNR2525M12	25	25	32,0	150	28,0	8,5	8,5	CN..120408	512.112	513.023	515.018	511.023	514.123	15 IP
PCSNR3225P12	32	25	32,0	170	32,0	8,5	8,5	CN..120408	512.112	513.023	515.018	511.023	514.123	15 IP
PCSNR3232P19	32	32	40,0	170	40,0	12,7	12,7	CN..190612	512.123	513.033	515.022	511.033	514.133	25 IP
left hand														
PCSNL2020K12	20	20	25,0	125	26,0	8,5	8,5	CN..120408	512.112	513.023	515.018	511.023	514.123	15 IP
PCSNL2525M12	25	25	32,0	150	28,0	8,5	8,5	CN..120408	512.112	513.023	515.018	511.023	514.123	15 IP
PCSNL3225P12	32	25	32,0	170	32,0	8,5	8,5	CN..120408	512.112	513.023	515.018	511.023	514.123	15 IP
PCSNL3232P19	32	32	40,0	170	40,0	12,7	12,7	CN..190612	512.123	513.033	515.022	511.033	514.133	25 IP

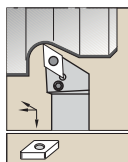

See pages B50–B58 and B176–B178 for inserts.

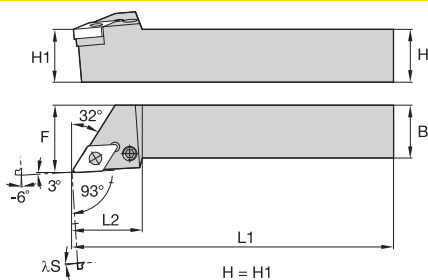

■ PDJN 93°



O.D./I.D. Tooling

catalogue number	H	B	F	L1	L2	λS°	gage insert	shim	shim pin	punch pin	lever	lever screw	Torx Plus
right hand													
PDJNR1616H11	16	16	20,0	100	22,0	-6,0	DN..110408	512.060	513.060	515.018	511.060	514.118	10 IP
PDJNR2020K11	20	20	25,0	125	30,0	-7,0	DN..110408	512.060	513.060	515.018	511.060	514.118	10 IP
PDJNR2020K15	20	20	25,0	125	36,0	-7,0	DN..150608	512.153	513.023	515.018	511.024	514.128	15 IP
PDJNR2525M11	25	25	32,0	150	30,0	-7,0	DN..110408	512.060	513.060	515.018	511.060	514.118	10 IP
PDJNR2525M15	25	25	32,0	150	36,0	-7,0	DN..150608	512.153	513.023	515.018	511.024	514.128	15 IP
PDJNR3225P15	32	25	32,0	170	38,0	-7,0	DN..150608	512.153	513.023	515.018	511.024	514.128	15 IP
PDJNR3232P15	32	32	40,0	170	38,0	-7,0	DN..150608	512.153	513.023	515.018	511.024	514.128	15 IP
PDJNR4025R15	40	25	32,0	200	38,0	-7,0	DN..150608	512.153	513.023	515.018	511.024	514.128	15 IP
left hand													
PDJNL1616H11	16	16	20,0	100	22,0	-6,0	DN..110408	512.060	513.060	515.018	511.060	514.118	10 IP
PDJNL2020K11	20	20	25,0	125	30,0	-7,0	DN..110408	512.060	513.060	515.018	511.060	514.118	10 IP
PDJNL2020K15	20	20	25,0	125	36,0	-7,0	DN..150608	512.153	513.023	515.018	511.024	514.128	15 IP
PDJNL2525M11	25	25	32,0	150	30,0	-7,0	DN..110408	512.060	513.060	515.018	511.060	514.118	10 IP
PDJNL2525M15	25	25	32,0	150	36,0	-7,0	DN..150608	512.153	513.023	515.018	511.024	514.128	15 IP
PDJNL3225P15	32	25	32,0	170	38,0	-7,0	DN..150608	512.153	513.023	515.018	511.024	514.128	15 IP
PDJNL3232P15	32	32	40,0	170	38,0	-7,0	DN..150608	512.153	513.023	515.018	511.024	514.128	15 IP
PDJNL4025R15	40	25	32,0	200	38,0	-7,0	DN..150608	512.153	513.023	515.018	511.024	514.128	15 IP

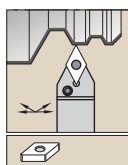

See pages B50–B58 and B176–B178 for inserts.

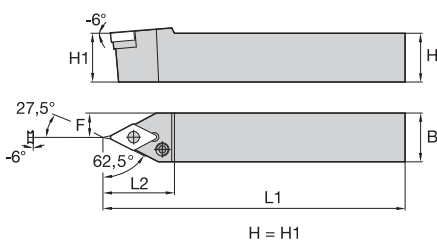

■ PDNN 62,5°



catalogue number	H	B	F	L1	L2	gage insert	shim	shim pin	punch pin	lever	lever screw	Torx Plus
right hand												
PDNNR2020K11	20	20	10,0	125	24,0	DN..110408	512.060	513.060	515.018	511.060	514.118	10 IP
PDNNR2020K15	20	20	10,0	125	36,0	DN..150608	512.153	513.023	515.018	511.024	514.128	15 IP
PDNNR2525M15	25	25	12,5	150	36,0	DN..150608	512.153	513.023	515.018	511.024	514.128	15 IP
PDNNR4025M15	40	25	12,5	150	36,0	DN..150608	512.153	513.023	515.018	511.024	514.128	15 IP
left hand												
PDNNL2020K11	20	20	10,0	125	24,0	DN..110408	512.060	513.060	515.018	511.060	514.118	10 IP
PDNNL2020K15	20	20	10,0	125	36,0	DN..150608	512.153	513.023	515.018	511.024	514.128	15 IP
PDNNL2525M11	25	25	12,5	150	30,0	DN..110408	512.060	513.060	515.018	511.060	514.118	10 IP
PDNNL2525M15	25	25	12,5	150	36,0	DN..150608	512.153	513.023	515.018	511.024	514.128	15 IP
PDNNL4025M15	40	25	12,5	150	36,0	DN..150608	512.153	513.023	515.018	511.024	514.128	15 IP

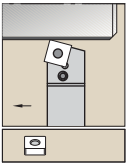

See pages B59–B66 and B178–B179 for inserts.

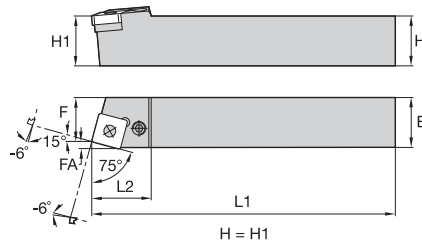

■ **PSBN 75°**



catalogue number	H	B	F	L1	L2	FA	gage insert	shim	shim pin	punch pin	lever	lever screw	Torx Plus
right hand													
PSBNR2020K12	20	20	17,0	125	26,0	3,1	SN..120408	512.063	513.023	515.018	511.023	514.123	15 IP
PSBNR2525M12	25	25	22,0	150	26,0	3,1	SN..120408	512.063	513.023	515.018	511.023	514.123	15 IP
PSBNR2525M15	25	25	22,0	150	36,0	3,8	SN..150608	512.025	513.025	515.022	511.025	514.125	15 IP
PSBNR3225P12	32	25	22,0	170	26,0	3,1	SN..120408	512.063	513.023	515.018	511.023	514.123	15 IP
PSBNR3232P15	32	32	27,0	170	33,0	3,8	SN..150608	512.025	513.025	515.022	511.025	514.125	15 IP
PSBNR3232P19	32	32	27,0	170	40,0	4,6	SN..190612	512.083	513.033	515.022	511.033	514.133	25 IP
PSBNR4040S19	40	40	35,0	250	38,0	4,6	SN..190612	512.083	513.033	515.022	511.033	514.133	25 IP
PSBNR4040S25	40	40	35,0	250	47,0	5,9	SN..250724	512.092	513.038	515.028	511.038	514.138	30 IP
left hand													
PSBNL2020K12	20	20	17,0	125	26,0	3,1	SN..120408	512.063	513.023	515.018	511.023	514.123	15 IP
PSBNL2525M12	25	25	22,0	150	26,0	3,1	SN..120408	512.063	513.023	515.018	511.023	514.123	15 IP
PSBNL2525M15	25	25	22,0	150	36,0	3,8	SN..150608	512.025	513.025	515.022	511.025	514.125	15 IP
PSBNL3225P12	32	25	22,0	170	26,0	3,1	SN..120408	512.063	513.023	515.018	511.023	514.123	15 IP
PSBNL3225P15	32	25	22,0	170	33,0	3,8	SN..150608	512.025	513.025	515.022	511.025	514.125	15 IP
PSBNL3232P15	32	32	27,0	170	33,0	3,8	SN..150608	512.025	513.025	515.022	511.025	514.125	15 IP
PSBNL3232P19	32	32	27,0	170	40,0	4,6	SN..190612	512.083	513.033	515.022	511.033	514.133	25 IP
PSBNL4040S19	40	40	35,0	250	38,0	4,6	SN..190612	512.083	513.033	515.022	511.033	514.133	25 IP
PSBNL4040S25	40	40	35,0	250	47,0	5,9	SN..250724	512.092	513.038	515.028	511.038	514.138	30 IP

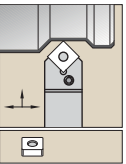

See pages B59–B66 and B178–B179 for inserts.

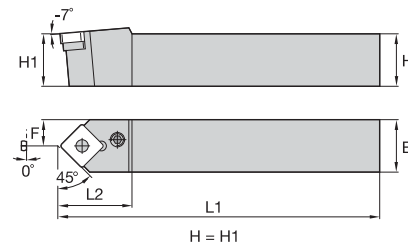

■ **PSDN 45°**



catalogue number	H	B	F	L1	L2	gage insert	shim	shim pin	punch pin	lever	lever screw	Torx Plus
PSDNN1616H09	16	16	8,0	100	20,0	SN..090308	512.053	513.019	515.018	511.018	514.118	10 IP
PSDNN2020K12	20	20	10,0	125	26,0	SN..120408	512.063	513.023	515.018	511.023	514.123	15 IP
PSDNN2525M12	25	25	12,5	150	26,0	SN..120408	512.063	513.023	515.018	511.023	514.123	15 IP
PSDNN3225P12	32	25	12,5	170	28,0	SN..120408	512.063	513.023	515.018	511.023	514.123	15 IP
PSDNN3225P19	32	25	12,5	170	40,0	SN..190612	512.083	513.033	515.022	511.033	514.133	25 IP
PSDNN3232P19	32	32	16,0	170	40,0	SN..190612	512.083	513.033	515.022	511.033	514.133	25 IP
PSDNN4040S25	40	40	20,0	250	47,0	SN..250724	512.092	513.038	515.028	511.038	514.138	30 IP

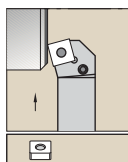

See pages B59–B66 and B178–B179 for inserts.

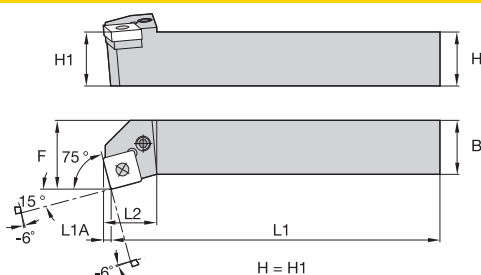

■ **PSKN 75°**



O.D./I.D. Tooling

catalogue number	H	B	F	L1	L2	L1A	gage insert	shim	shim pin	punch pin	lever	lever screw	Torx Plus
right hand													
PSKNR1616H09	16	16	20,0	100	20,0	2,2	SN..090308	512.053	513.019	515.018	511.018	514.118	10 IP
PSKNR2020K12	20	20	25,0	125	23,0	3,1	SN..120408	512.063	513.023	515.018	511.023	514.123	15 IP
PSKNR2525M12	25	25	32,0	150	23,0	3,1	SN..120408	512.063	513.023	515.018	511.023	514.123	15 IP
PSKNR3232P15	32	32	40,0	170	33,0	3,8	SN..150608	512.025	513.025	515.022	511.025	514.125	15 IP
PSKNR3232P19	32	32	40,0	170	37,5	4,6	SN..190612	512.083	513.033	515.022	511.033	514.133	25 IP
left hand													
PSKNL2020K12	20	20	25,0	125	23,0	3,1	SN..120408	512.063	513.023	515.018	511.023	514.123	15 IP
PSKNL2525M12	25	25	32,0	150	23,0	3,1	SN..120408	512.063	513.023	515.018	511.023	514.123	15 IP
PSKNL3232P19	32	32	40,0	170	37,5	4,6	SN..190612	512.083	513.033	515.022	511.033	514.133	25 IP
PSKNL4040S19	40	40	50,0	250	37,5	4,6	SN..190612	512.083	513.033	515.022	511.033	514.133	25 IP

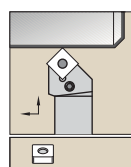

See pages B59–B66 and B178–B179 for inserts.

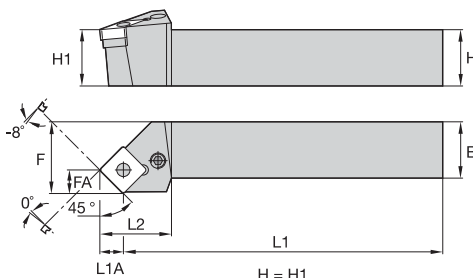

■ **PSSN 45°**



catalogue number	H	B	F	L1	L2	FA	L1A	gage insert	shim	shim pin	punch pin	lever	lever screw	Torx Plus
right hand														
PSSNR2020K09	20	20	25,0	125	26,0	6,1	6,1	SN..090308	512.053	513.019	515.018	511.018	514.118	10 IP
PSSNR2020K12	20	20	25,0	125	28,0	8,3	8,3	SN..120408	512.063	513.023	515.018	511.023	514.123	15 IP
PSSNR2525M12	25	25	32,0	150	28,0	8,3	8,3	SN..120408	512.063	513.023	515.018	511.023	514.123	15 IP
PSSNR2525M15	25	25	32,0	150	32,0	10,2	10,2	SN..150608	512.025	513.025	515.022	511.025	514.125	15 IP
PSSNR3225P12	32	25	32,0	170	29,0	8,3	8,3	SN..120408	512.063	513.023	515.018	511.023	514.123	15 IP
PSSNR3232P15	32	32	40,0	170	32,0	10,2	10,2	SN..150608	512.025	513.025	515.022	511.025	514.125	15 IP
PSSNR3232P19	32	32	40,0	170	37,5	12,5	12,5	SN..190612	512.083	513.033	515.022	511.033	514.133	25 IP
PSSNR4040S19	40	40	50,0	250	37,5	12,5	12,5	SN..190612	512.083	513.033	515.022	511.033	514.133	25 IP
left hand														
PSSNL2020K12	20	20	25,0	125	28,0	8,3	8,3	SN..120408	512.063	513.023	515.018	511.023	514.123	15 IP
PSSNL2525M12	25	25	32,0	150	28,0	8,3	8,3	SN..120408	512.063	513.023	515.018	511.023	514.123	15 IP
PSSNL2525M15	25	25	32,0	150	32,0	10,2	10,2	SN..150608	512.025	513.025	515.022	511.025	514.125	15 IP
PSSNL3225P12	32	25	32,0	170	29,0	8,3	8,3	SN..120408	512.063	513.023	515.018	511.023	514.123	15 IP
PSSNL3232P19	32	32	40,0	170	37,5	12,5	12,5	SN..190612	512.083	513.033	515.022	511.033	514.133	25 IP
PSSNL4040S19	40	40	50,0	250	37,5	12,5	12,5	SN..190612	512.083	513.033	515.022	511.033	514.133	25 IP

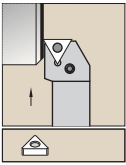

See pages B66–B73 and B179–B180 for inserts.

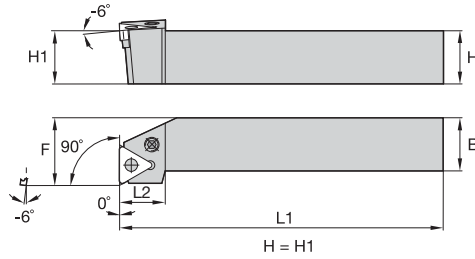

■ PTFN 90°



catalogue number	H	B	F	L1	L2	gage insert	shim	shim pin	punch pin	lever	lever screw	Torx Plus
right hand												
PTFNR2020K16	20	20	25,0	125	20,0	TN..160408	512.013	513.018	515.018	511.018	514.118	10 IP
PTFNR2525M16	25	25	32,0	150	20,0	TN..160408	512.013	513.018	515.018	511.018	514.118	10 IP
left hand												
PTFNL1616H16	16	16	20,0	100	20,0	TN..160408	512.013	513.018	515.018	511.018	514.118	10 IP
PTFNL2020K16	20	20	25,0	125	20,0	TN..160408	512.013	513.018	515.018	511.018	514.118	10 IP
PTFNL2525M16	25	25	32,0	150	20,0	TN..160408	512.013	513.018	515.018	511.018	514.118	10 IP

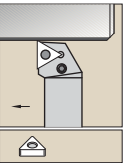

See pages B66–B73 and B179–B180 for inserts.

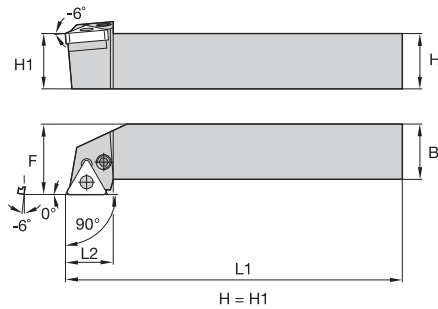

■ PTGN 90°



catalogue number	H	B	F	L1	L2	gage insert	shim	shim pin	punch pin	lever	lever screw	Torx Plus
right hand												
PTGNR1616H16	16	16	20,0	100	20,0	TN..160408	512.013	513.018	515.018	511.018	514.118	10 IP
PTGNR2020K16	20	20	25,0	125	20,0	TN..160408	512.013	513.018	515.018	511.018	514.118	10 IP
PTGNR2525M16	25	25	32,0	150	20,0	TN..160408	512.013	513.018	515.018	511.018	514.118	10 IP
PTGNR2525M22	25	25	32,0	150	26,0	TN..220408	512.023	513.023	515.018	511.023	514.123	15 IP
left hand												
PTGNL1616H16	16	16	20,0	100	20,0	TN..160408	512.013	513.018	515.018	511.018	514.118	10 IP
PTGNL2020K16	20	20	25,0	125	20,0	TN..160408	512.013	513.018	515.018	511.018	514.118	10 IP
PTGNL2525M16	25	25	32,0	150	20,0	TN..160408	512.013	513.018	515.018	511.018	514.118	10 IP
PTGNL2525M22	25	25	32,0	150	26,0	TN..220408	512.023	513.023	515.018	511.023	514.123	15 IP

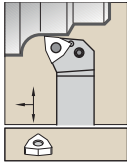

See pages B79–B83 and B181 for inserts.

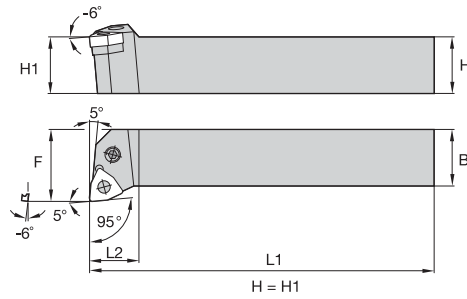

PWLN 95°

O.D./I.D. Tooling

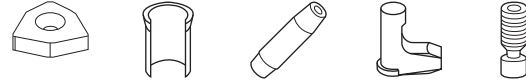

catalogue number	H	B	F	L1	L2	gage insert	shim	shim pin	punch pin	lever	lever screw	Torx Plus
right hand												
PWLN1616H06	16	16	20,0	100	14,0	WN..060404	512.134	513.018	515.018	511.018	514.118	10 IP
PWLN2020K06	20	20	25,0	125	14,0	WN..060404	512.134	513.018	515.018	511.018	514.118	10 IP
PWLN2020K08	20	20	25,0	125	20,0	WN..080408	512.135	513.023	515.018	511.023	514.123	15 IP
left hand												
PWLN1616H06	16	16	20,0	100	14,0	WN..060404	512.134	513.018	515.018	511.018	514.118	10 IP
PWLN2020K06	20	20	25,0	125	14,0	WN..060404	512.134	513.018	515.018	511.018	514.118	10 IP
PWLN2020K08	20	20	25,0	125	20,0	WN..080408	512.135	513.023	515.018	511.023	514.123	15 IP
PWLN2525M08	25	25	32,0	150	26,0	WN..080408	512.135	513.023	515.018	511.023	514.123	15 IP
PWLN3225P08	32	25	32,0	170	26,0	WN..080408	512.135	513.023	515.018	511.023	514.123	15 IP

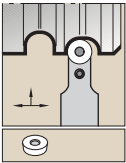

See pages B101–B102 for inserts.

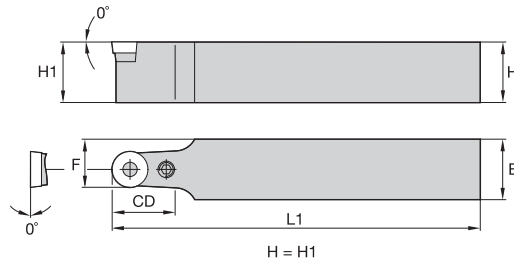

■ PRCC



catalogue number	H	B	F	L1	CD	gage insert	shim	clamp stud	clamp screw	wrench size clamp screw
PRCCN2020K08H1	20	20	14,0	125	16,0	RC..0803M0	—	119.069	121.408	2 mm
PRCCN2020K10H1	20	20	15,0	125	24,0	RC..1003M0	169.325	119.069	121.408	2 mm
PRCCN2525M08H1	25	25	16,5	150	16,0	RC..0803M0	—	119.069	121.408	2 mm
PRCCN2525M10H1	25	25	17,5	150	24,0	RC..1003M0	169.325	119.069	121.408	2 mm
PRCCN2525M12H1	25	25	18,5	150	24,0	RC..1204M0	169.322	119.071	121.512	2.5 mm
PRCCN3225P16H1	32	25	20,5	170	33,0	RC..1606M0	169.327	410.081	121.616	3 mm
PRCCN3232P20H1	32	32	26,0	170	32,0	RC..2006M0	169.333	119.073	121.820	4 mm
PRCCN4040S25H1	40	40	32,5	250	78,0	RC..2507M0	169.337	118.404	121.820	4 mm

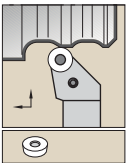

See pages B101–B102 for inserts.

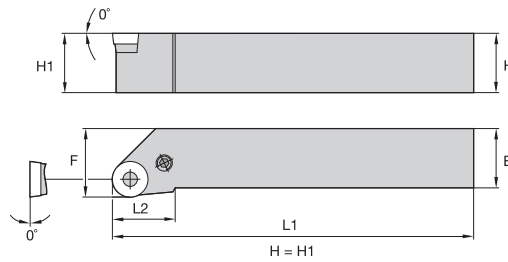

■ PRGC



catalogue number	H	B	F	L1	L2	gage insert	shim	clamp stud	clamp screw	wrench size clamp screw
right hand										
PRGCR2020K10H1	20	20	25,0	125	26,0	RC..1003M0	169.325	119.069	121.408	2 mm
PRGCR2525M08H1	25	25	29,0	150	26,0	RC..0803M0	—	119.069	121.408	2 mm
PRGCR2525M10H1	25	25	30,0	150	26,0	RC..1003M0	169.325	119.069	121.408	2 mm
PRGCR2525M12H1	25	25	32,0	150	26,0	RC..1204M0	169.322	119.071	121.512	2.5 mm
PRGCR3225P16H1	32	25	32,0	170	36,0	RC..1606M0	169.327	118.205	121.616	3 mm
PRGCR3232P20H1	32	32	40,0	170	40,0	RC..2006M0	169.333	119.073	121.820	4 mm
PRGCR4040S25H1	40	40	50,0	250	47,0	RC..2507M0	169.337	118.404	121.820	4 mm
left hand										
PRGCL2525M08H1	25	25	29,0	150	26,0	RC..0803M0	—	119.069	121.408	2 mm
PRGCL2525M10H1	25	25	30,0	150	26,0	RC..1003M0	169.325	119.069	121.408	2 mm
PRGCL2525M12H1	25	25	32,0	150	26,0	RC..1204M0	169.322	119.071	121.512	2.5 mm
PRGCL3225P16H1	32	25	32,0	170	36,0	RC..1606M0	169.327	118.205	121.616	3 mm
PRGCL3232P20H1	32	32	40,0	170	40,0	RC..2006M0	169.333	119.073	121.820	4 mm
PRGCL4040S25H1	40	40	50,0	250	47,0	RC..2507M0	169.337	118.404	121.820	4 mm

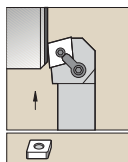

See pages B40–B49 and B174–B176 for inserts.

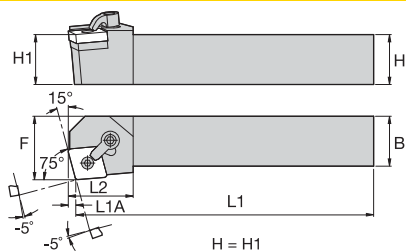

MCKN 75°

O.D./I.D. Tooling



catalogue number	H	B	F	L1	L2	L1A	gage insert	shim	lock pin	hex (mm)	clamp	clamp screw	hex (mm)
right hand													
MCKNR2525M12	25	25	32,0	150	32,0	3,1	CN..120408	ICSN432	KLM46	2.5 mm	CKM21	STCM20	3 mm
MCKNR3225P12	32	25	32,0	170	32,0	3,1	CN..120408	ICSN432	KLM46	2.5 mm	CKM21	STCM20	3 mm
MCKNR3225P16	32	25	32,0	170	33,0	3,6	CN..160612	ICSN533	KLM58	3 mm	CKM21	STCM20	3 mm
MCKNR3232P19	32	32	40,0	170	38,0	4,4	CN..190612	ICSN633	KLM68	4 mm	CKM12	STCM4	4 mm
left hand													
MCKNL2525M12	25	25	32,0	150	32,0	3,1	CN..120408	ICSN432	KLM46	2.5 mm	CKM21	STCM20	3 mm
MCKNL3225P16	32	25	32,0	170	33,0	3,6	CN..160612	ICSN533	KLM58	3 mm	CKM21	STCM20	3 mm
MCKNL3232P19	32	32	40,0	170	38,0	4,4	CN..190612	ICSN633	KLM68	4 mm	CKM12	STCM4	4 mm

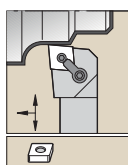

See pages B40–B49 and B174–B176 for inserts.

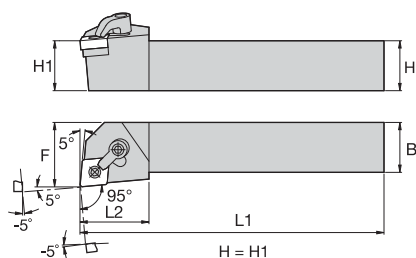

MCLN 95°

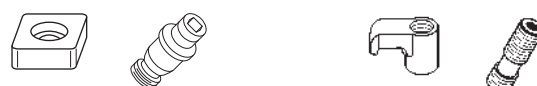

catalogue number	H	B	F	L1	L2	gage insert	shim	lock pin	hex (mm)	clamp	clamp screw	hex (mm)
right hand												
MCLNR1616H09	16	16	20,0	100	25,0	CN..090308	—	KLM33	2 mm	CKM6	STCM5	2.5 mm
MCLNR1616H12	16	16	20,0	100	32,0	CN..120408	ICSN432	KLM46	2.5 mm	CKM21	STCM20	3 mm
MCLNR2020K09	20	20	25,0	125	25,0	CN..090308	ICSN332	KLM34L	2 mm	CKM6	STCM5	2.5 mm
MCLNR2020K12	20	20	25,0	125	32,0	CN..120408	ICSN432	KLM46	2.5 mm	CKM21	STCM20	3 mm
MCLNR2525M09	25	25	32,0	150	25,0	CN..090308	ICSN332	KLM34L	2 mm	CKM6	STCM5	2.5 mm
MCLNR2525M12	25	25	32,0	150	32,0	CN..120408	ICSN432	KLM46	2.5 mm	CKM21	STCM20	3 mm
MCLNR2525M16	25	25	32,0	150	33,0	CN..160612	ICSN533	KLM58	3 mm	CKM21	STCM20	3 mm
MCLNR2525M19	25	25	32,0	150	38,0	CN..190612	ICSN633	KLM68	4 mm	CKM12	STCM4	4 mm
MCLNR3225P12	32	25	32,0	170	32,0	CN..120408	ICSN432	KLM46	2.5 mm	CKM21	STCM20	3 mm
MCLNR3225P16	32	25	32,0	170	33,0	CN..160612	ICSN533	KLM58	3 mm	CKM21	STCM20	3 mm
MCLNR3225P19	32	25	32,0	170	38,0	CN..190612	ICSN633	KLM68	4 mm	CKM12	STCM4	4 mm
MCLNR3232P12	32	32	40,5	171	32,0	CN..120408	ICSN432	KLM46	2.5 mm	CKM21	STCM20	3 mm
MCLNR3232P16	32	32	40,5	171	33,0	CN..160612	ICSN533	KLM58	3 mm	CKM21	STCM20	3 mm
MCLNR3232P19	32	32	40,0	170	38,0	CN..190612	ICSN633	KLM68	4 mm	CKM12	STCM4	4 mm
MCLNR4040R19	40	40	50,0	200	38,0	CN..190612	ICSN633	KLM68	4 mm	CKM12	STCM4	4 mm

(continued)

(MCLN 95° continued)



catalogue number	H	B	F	L1	L2	gage insert	shim	lock pin	hex (mm)	clamp	clamp screw	hex (mm)
left hand												
MCLNL1616H09	16	16	20,0	100	25,0	CN..090308	—	KLM33	2 mm	CKM6	STCM5	2.5 mm
MCLNL1616H12	16	16	20,0	100	32,0	CN..120408	ICSN432	KLM46	2.5 mm	CKM21	STCM20	3 mm
MCLNL2020K12	20	20	25,0	125	32,0	CN..120408	ICSN432	KLM46	2.5 mm	CKM21	STCM20	3 mm
MCLNL2525M09	25	25	32,0	150	25,0	CN..090308	ICSN332	KLM34L	2 mm	CKM6	STCM5	2.5 mm
MCLNL2525M12	25	25	32,0	150	32,0	CN..120408	ICSN432	KLM46	2.5 mm	CKM21	STCM20	3 mm
MCLNL2525M16	25	25	32,0	150	33,0	CN..160612	ICSN533	KLM58	3 mm	CKM21	STCM20	3 mm
MCLNL2525M19	25	25	32,0	150	38,0	CN..190612	ICSN633	KLM68	4 mm	CKM12	STCM4	4 mm
MCLNL3225P12	32	25	32,0	170	32,0	CN..120408	ICSN432	KLM46	2.5 mm	CKM21	STCM20	3 mm
MCLNL3225P16	32	25	32,0	170	33,0	CN..160612	ICSN533	KLM58	3 mm	CKM21	STCM20	3 mm
MCLNL3225P19	32	25	32,0	170	38,0	CN..190612	ICSN633	KLM68	4 mm	CKM12	STCM4	4 mm
MCLNL3232P12	32	32	40,5	171	32,0	CN..120408	ICSN432	KLM46	2.5 mm	CKM21	STCM20	3 mm
MCLNL3232P16	32	32	40,5	171	33,0	CN..160612	ICSN533	KLM58	3 mm	CKM21	STCM20	3 mm
MCLNL3232P19	32	32	40,0	170	38,0	CN..190612	ICSN633	KLM68	4 mm	CKM12	STCM4	4 mm
MCLNL4040R19	40	40	50,0	200	38,0	CN..190612	ICSN633	KLM68	4 mm	CKM12	STCM4	4 mm

O.D./I.D. Tooling

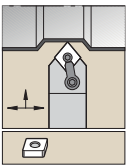

See pages B40–B49 and B174–B176 for inserts.

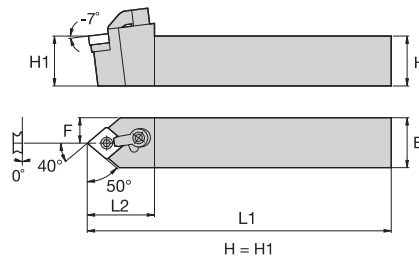
MCMN 50°

catalogue number	H	B	F	L1	L2	gage insert	shim	lock pin	hex (mm)	clamp	clamp screw	hex (mm)
MCMNN2020K12	20	20	10,0	125	32,0	CN..120408	ICSN432	KLM46	2.5 mm	CKM21	STCM20	3 mm
MCMNN2525M12	25	25	12,9	150	32,0	CN..120408	ICSN432	KLM46	2.5 mm	CKM21	STCM20	3 mm
MCMNN3225P16	32	25	12,9	170	38,0	CN..160612	ICSN533	KLM58	3 mm	CKM21	STCM20	3 mm
MCMNN4040R19	40	40	20,0	200	42,0	CN..190612	ICSN633	KLM68	4 mm	CKM12	STCM4	4 mm

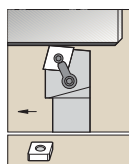

See pages B40–B49 and B174–B176 for inserts.

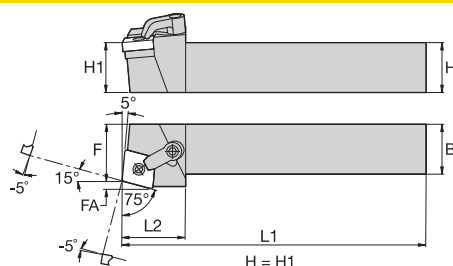

MCRN 75°



O.D./I.D. Tooling

catalogue number	H	B	F	L1	L2	FA	gage insert	shim	lock pin	hex (mm)	clamp	clamp screw	hex (mm)
right hand													
MCRNR2020K12	20	20	25,0	125	32,0	3,3	CN..120408	ICSN432	KLM46	2.5 mm	CKM21	STCM20	3 mm
MCRNR2525M12	25	25	32,0	150	32,0	3,3	CN..120408	ICSN432	KLM46	2.5 mm	CKM21	STCM20	3 mm
MCRNR3225P12	32	25	32,0	170	32,0	3,3	CN..120408	ICSN432	KLM46	2.5 mm	CKM21	STCM20	3 mm
MCRNR3232P16	32	32	32,0	170	33,0	4,2	CN..160612	ICSN533	KLM58	3 mm	CKM21	STCM20	3 mm
MCRNR3232P19	32	32	40,0	170	38,0	4,6	CN..190612	ICSN633	KLM68	4 mm	CKM12	STCM4	4 mm
left hand													
MCRNL2020K12	20	20	25,0	125	32,0	3,3	CN..120408	ICSN432	KLM46	2.5 mm	CKM21	STCM20	3 mm
MCRNL2525M12	25	25	32,0	150	32,0	3,3	CN..120408	ICSN432	KLM46	2.5 mm	CKM21	STCM20	3 mm
MCRNL3225P12	32	25	32,0	170	32,0	3,3	CN..120408	ICSN432	KLM46	2.5 mm	CKM21	STCM20	3 mm
MCRNL3232P16	32	32	32,0	170	33,0	4,2	CN..160612	ICSN533	KLM58	3 mm	CKM21	STCM20	3 mm
MCRNL3232P19	32	32	40,0	170	38,0	4,6	CN..190612	ICSN633	KLM68	4 mm	CKM12	STCM4	4 mm

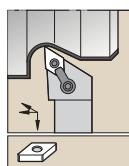

See pages B50–B58 and B176–B178 for inserts.

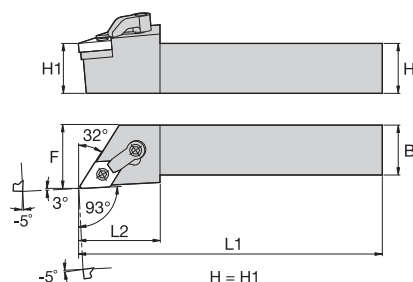

MDJN 93°



catalogue number	H	B	F	L1	L2	gage insert	shim	lock pin	hex (mm)	clamp	clamp screw	hex (mm)
right hand												
MDJNR1616H11	16	16	20,0	100	32,0	DN..110408	IDSN322	KLM34L	2 mm	CKM7	STCM5	2.5 mm
MDJNR2020K11	20	20	25,0	125	32,0	DN..110408	IDSN322	KLM34L	2 mm	CKM7	STCM5	2.5 mm
MDJNR2020K15	20	20	25,0	125	36,0	DN..150612	IDSN432	KLM46L	2.5 mm	CKM22	STCM20	3 mm
MDJNR2525M11	25	25	32,0	150	32,0	DN..110408	IDSN322	KLM34L	2 mm	CKM7	STCM5	2.5 mm
MDJNR2525M15	25	25	32,0	150	36,0	DN..150612	IDSN432	KLM46L	2.5 mm	CKM22	STCM20	3 mm
MDJNR3225P15	32	25	32,0	170	36,0	DN..150612	IDSN432	KLM46L	2.5 mm	CKM22	STCM20	3 mm
MDJNR3232P15	32	32	40,5	173	32,0	DN..150608	IDSN432	KLM46L	2.5 mm	CKM22	STCM20	3 mm
left hand												
MDJNL1616H11	16	16	20,0	100	32,0	DN..110408	IDSN322	KLM34L	2 mm	CKM7	STCM5	2.5 mm
MDJNL2020K11	20	20	25,0	125	32,0	DN..110408	IDSN322	KLM34L	2 mm	CKM7	STCM5	2.5 mm
MDJNL2020K15	20	20	25,0	125	36,0	DN..150612	IDSN432	KLM46L	2.5 mm	CKM22	STCM20	3 mm
MDJNL2525M11	25	25	32,0	150	32,0	DN..110408	IDSN322	KLM34L	2 mm	CKM7	STCM5	2.5 mm
MDJNL2525M15	25	25	32,0	150	36,0	DN..150612	IDSN432	KLM46L	2.5 mm	CKM22	STCM20	3 mm
MDJNL3225P15	32	25	32,0	170	36,0	DN..150612	IDSN432	KLM46L	2.5 mm	CKM22	STCM20	3 mm
MDJNL3232P15	32	32	40,5	173	32,0	DN..150608	IDSN432	KLM46L	2.5 mm	CKM22	STCM20	3 mm

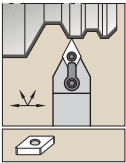

See pages B50–B58 and B176–B178 for inserts.

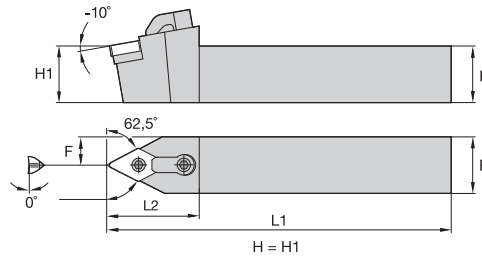

■ MDNN 62,5°



catalogue number	H	B	F	L1	L2	gage insert	shim	lock pin	hex (mm)	clamp	clamp screw	hex (mm)
right hand												
MDNNR2525M15	25	25	12,5	150	41,0	DN..150612	IDSN432	KLM46L	2.5 mm	CKM22	STCM20	3 mm
MDNNR3225P15	32	25	12,5	170	41,0	DN..150612	IDSN432	KLM46L	2.5 mm	CKM22	STCM20	3 mm
left hand												
MDNNL2525M15	25	25	12,5	150	41,0	DN..150612	IDSN432	KLM46L	2.5 mm	CKM22	STCM20	3 mm
MDNNL3225P15	32	25	12,5	170	41,0	DN..150612	IDSN432	KLM46L	2.5 mm	CKM22	STCM20	3 mm

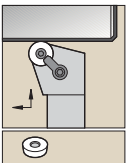

See pages B58–B59 for inserts.

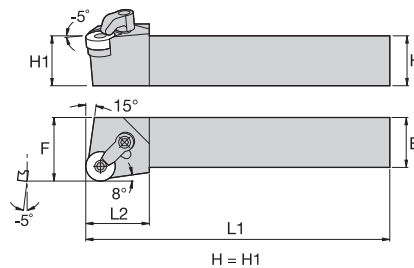

■ MRGN



catalogue number	H	B	F	L1	L2	gage insert	shim	lock pin	hex (mm)	clamp	clamp screw	hex (mm)
right hand												
MRGNR2525M12	25	25	32,0	150	32,0	RN..120400	IRSN43	KLM46	2.5 mm	CKM21	STCM20	3 mm
MRGNR3232P19	32	32	40,0	170	38,0	RN..190600	IRSN63	KLM68	4 mm	CKM12	STCM4	4 mm
left hand												
MRGNL2525M12	25	25	32,0	150	32,0	RN..120400	IRSN43	KLM46	2.5 mm	CKM21	STCM20	3 mm
MRGNL3232P19	32	32	40,0	170	38,0	RN..190600	IRSN63	KLM68	4 mm	CKM12	STCM4	4 mm

O.D./I.D. Tooling

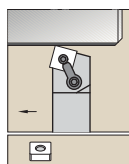

See pages B59–B66 and B178–B179 for inserts.

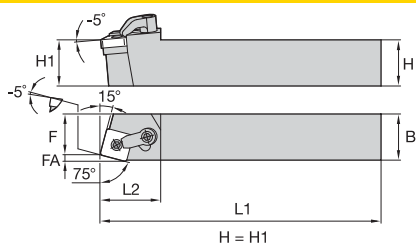

■ **MSBN 75°**

O.D./I.D. Tooling



catalogue number	H	B	F	L1	L2	FA	gage insert	shim	lock pin	hex (mm)	clamp	clamp screw	hex (mm)
right hand													
MSBNR2020K12	20	20	17,0	125	32,0	3,1	SN..120408	ISSN433	KLM46	2.5 mm	CKM21	STCM20	3 mm
MSBNR2525M12	25	25	22,0	150	32,0	3,1	SN..120408	ISSN433	KLM46	2.5 mm	CKM21	STCM20	3 mm
MSBNR2525M15	25	25	22,0	150	35,0	3,8	SN..150612	ISSN533	KLM58	3 mm	CKM21	STCM20	3 mm
MSBNR3225P12	32	25	22,0	170	32,0	3,1	SN..120408	ISSN433	KLM46	2.5 mm	CKM21	STCM20	3 mm
MSBNR3232P15	32	32	27,0	170	35,0	3,8	SN..150612	ISSN533	KLM58	3 mm	CKM21	STCM20	3 mm
MSBNR3232P19	32	32	27,0	170	40,0	4,6	SN..190612	ISSN633	KLM68	4 mm	CKM12	STCM4	4 mm
MSBNR4040R19	40	40	35,0	200	40,0	4,6	SN..190612	ISSN633	KLM68	4 mm	CKM12	STCM4	4 mm
left hand													
MSBNL2020K12	20	20	17,0	125	32,0	3,1	SN..120408	ISSN433	KLM46	2.5 mm	CKM21	STCM20	3 mm
MSBNL2525M12	25	25	22,0	150	32,0	3,1	SN..120408	ISSN433	KLM46	2.5 mm	CKM21	STCM20	3 mm
MSBNL2525M15	25	25	22,0	150	35,0	3,8	SN..150612	ISSN533	KLM58	3 mm	CKM21	STCM20	3 mm
MSBNL3225P12	32	25	22,0	170	32,0	3,1	SN..120408	ISSN433	KLM46	2.5 mm	CKM21	STCM20	3 mm
MSBNL3232P15	32	32	27,0	170	35,0	3,8	SN..150612	ISSN533	KLM58	3 mm	CKM21	STCM20	3 mm
MSBNL3232P19	32	32	27,0	170	40,0	4,6	SN..190612	ISSN633	KLM68	4 mm	CKM12	STCM4	4 mm
MSBNL4040R19	40	40	35,0	200	40,0	4,6	SN..190612	ISSN633	KLM68	4 mm	CKM12	STCM4	4 mm

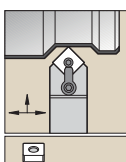

See pages B59–B66 and B178–B179 for inserts.

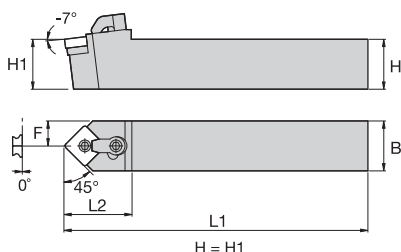

■ **MSDN 45°**



catalogue number	H	B	F	L1	L2	gage insert	shim	lock pin	hex (mm)	clamp	clamp screw	hex (mm)
MSDNN1616H09	16	16	8,0	100	28,0	SN..090308	ISSN332	KLM34L	2 mm	CKM19	STCM9	2.5 mm
MSDNN2020K12	20	20	10,0	125	32,0	SN..120408	ISSN432	KLM46	2.5 mm	CKM21	STCM20	3 mm
MSDNN2525M12	25	25	12,5	150	32,0	SN..120408	ISSN432	KLM46	2.5 mm	CKM21	STCM20	3 mm
MSDNN2525M15	25	25	12,5	150	35,0	SN..150612	ISSN533	KLM58	3 mm	CKM21	STCM20	3 mm
MSDNN3225P12	32	25	12,5	170	32,0	SN..120408	ISSN432	KLM46	2.5 mm	CKM21	STCM20	3 mm
MSDNN3232P19	32	32	16,0	170	42,0	SN..190612	ISSN633	KLM68	4 mm	CKM12	STCM4	4 mm

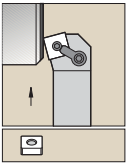

See pages B59–B66 and B178–B179 for inserts.

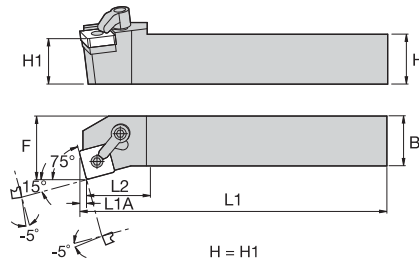

■ **MSKN 75°**



catalogue number	H	B	F	L1	L2	L1A	gage insert	shim	lock pin	hex (mm)	clamp	clamp screw	hex (mm)
right hand													
MSKNR2525M12	25	25	32,0	150	32,0	3,1	SN..120408	ISSN432	KLM46	2.5 mm	CKM21	STCM20	3 mm
MSKNR3225P12	32	25	32,0	170	32,0	3,1	SN..120408	ISSN432	KLM46	2.5 mm	CKM21	STCM20	3 mm
MSKNR3232P15	32	32	40,0	170	35,0	3,7	SN..150612	ISSN533	KLM58	3 mm	CKM21	STCM20	3 mm
MSKNR3232P19	32	32	40,0	170	40,0	4,6	SN..190612	ISSN633	KLM68	4 mm	CKM12	STCM4	4 mm
left hand													
MSKNL2020K12	20	20	25,0	125	32,0	3,1	SN..120408	ISSN432	KLM46	2.5 mm	CKM21	STCM20	3 mm
MSKNL2525M12	25	25	32,0	150	32,0	3,1	SN..120408	ISSN432	KLM46	2.5 mm	CKM21	STCM20	3 mm
MSKNL2525M15	25	25	32,0	150	35,0	3,7	SN..150612	ISSN433	KLM46	2.5 mm	CKM21	STCM20	3 mm
MSKNL3225P12	32	25	32,0	170	32,0	3,1	SN..120408	ISSN432	KLM46	2.5 mm	CKM21	STCM20	3 mm
MSKNL3232P15	32	32	40,0	170	35,0	3,7	SN..150612	ISSN533	KLM58	3 mm	CKM21	STCM20	3 mm
MSKNL3232P19	32	32	40,0	170	40,0	4,6	SN..190612	ISSN633	KLM68	4 mm	CKM12	STCM4	4 mm

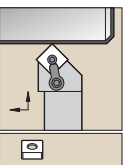

See pages B59–B66 and B178–B179 for inserts.

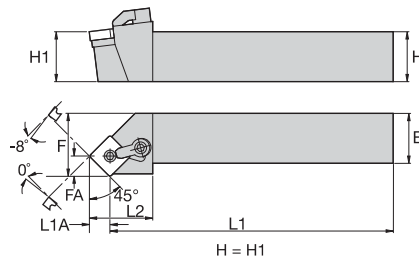

■ **MSSN 45°**



catalogue number	H	B	F	L1	L2	FA	L1A	gage insert	shim	lock pin	hex (mm)	clamp	clamp screw	hex (mm)
right hand														
MSSNR2020K12	20	20	25,0	125	32,0	8,3	8,3	SN..120408	ISSN433	KLM46	2.5 mm	CKM21	STCM20	3 mm
MSSNR2525M12	25	25	32,0	150	32,0	8,3	8,3	SN..120408	ISSN433	KLM46	2.5 mm	CKM21	STCM20	3 mm
MSSNR3232P19	32	32	40,0	170	40,0	12,5	12,5	SN..190612	ISSN633	KLM68	4 mm	CKM12	STCM4	4 mm
MSSNR4040R19	40	40	50,0	200	40,0	12,5	12,5	SN..190612	ISSN633	KLM68	4 mm	CKM12	STCM4	4 mm
left hand														
MSSNL2020K12	20	20	25,0	125	32,0	8,3	8,3	SN..120408	ISSN433	KLM46	2.5 mm	CKM21	STCM20	3 mm
MSSNL2525M12	25	25	32,0	150	32,0	8,3	8,3	SN..120408	ISSN433	KLM46	2.5 mm	CKM21	STCM20	3 mm
MSSNL3232P19	32	32	40,0	170	40,0	12,5	12,5	SN..190612	ISSN633	KLM68	4 mm	CKM12	STCM4	4 mm
MSSNL4040R19	40	40	50,0	200	40,0	12,5	12,5	SN..190612	ISSN633	KLM68	4 mm	CKM12	STCM4	4 mm

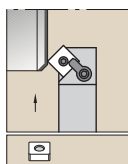

See pages B59–B66 and B178–B179 for inserts.

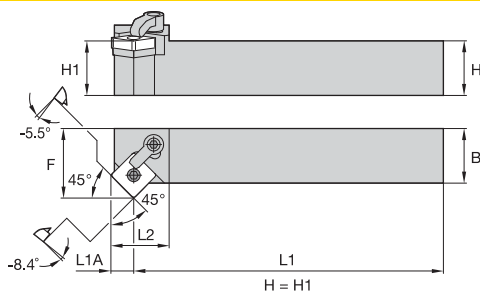

■ **MSZN 45°**



O.D./I.D. Tooling

catalogue number	H	B	F	L1	L2	L1A	gage insert	shim	lock pin	hex (mm)	clamp	clamp screw	hex (mm)
right hand													
MSZNR2525M12	25	25	32,0	150	25,0	8,5	SN..120408	ISSN432	KLM46	2.5 mm	CKM21	STCM20	3 mm
left hand													
MSZNL2525M12	25	25	32,0	150	25,0	8,5	SN..120408	ISSN432	KLM46	2.5 mm	CKM21	STCM20	3 mm

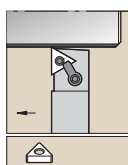

See pages B66–B73 and B179–B180 for inserts.

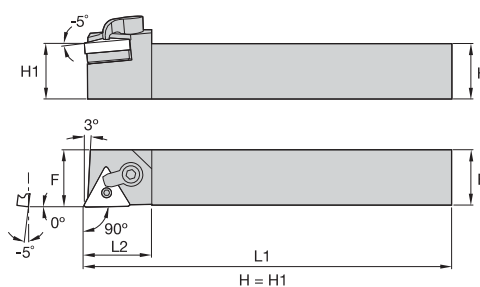

■ **MTAN-S 90°**



catalogue number	H	B	F	L1	L2	gage insert	shim	lock pin	hex (mm)	clamp	clamp screw	hex (mm)
right hand												
MTANRS2020K16	20	20	20,5	125	32,0	TN..160408	ITSN322	KLM34L	2 mm	CKM21	STCM20	3 mm
MTANRS2525M16	25	25	25,5	150	32,0	TN..160408	ITSN322	KLM34L	2 mm	CKM21	STCM20	3 mm
MTANRS2525M22	25	25	25,5	150	32,0	TN..220408	ITSN433	KLM46	2.5 mm	CKM9	STCM4	4 mm
left hand												
MTANLS2020K16	20	20	20,5	125	32,0	TN..160408	ITSN322	KLM34L	2 mm	CKM21	STCM20	3 mm
MTANLS2525M16	25	25	25,5	150	32,0	TN..160408	ITSN322	KLM34L	2 mm	CKM21	STCM20	3 mm
MTANLS2525M22	25	25	25,5	150	32,0	TN..220408	ITSN433	KLM46	2.5 mm	CKM9	STCM4	4 mm

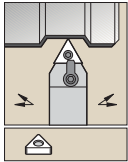

See pages B66–B73 and B179–B180 for inserts.

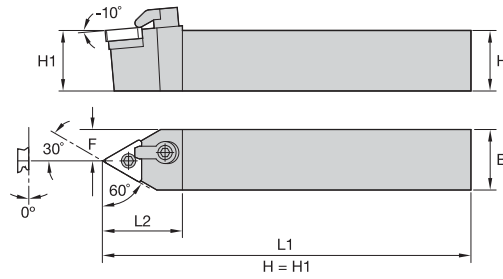

■ **MTEN-S 60°**



catalogue number	H	B	F	L1	L2	gage insert	shim	lock pin	hex (mm)	clamp	clamp screw	hex (mm)
MTENNS2020K16	20	20	10,0	125	32,0	TN..160408	ITSN322	KLM34L	2 mm	CKM21	STCM20	3 mm
MTENNS2525M16	25	25	12,0	150	32,0	TN..160408	ITSN322	KLM34L	2 mm	CKM21	STCM20	3 mm
MTENNS2525M22	25	25	12,0	150	35,0	TN..220408	ITSN433	KLM46	2.5 mm	CKM9	STCM4	4 mm
MTENNS3225P22	32	25	12,0	170	35,0	TN..220408	ITSN433	KLM46	2.5 mm	CKM9	STCM4	4 mm

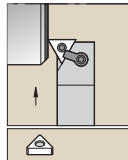

See pages B66–B73 and B179–B180 for inserts.

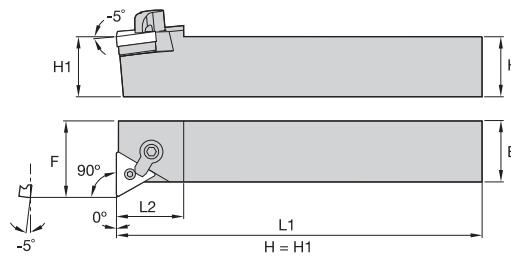

■ **MTFN 90°**



catalogue number	H	B	F	L1	L2	gage insert	shim	lock pin	hex (mm)	clamp	clamp screw	hex (mm)
right hand												
MTFNR2020K16	20	20	25,0	125	32,0	TN..160408	ITSN322	KLM34L	2 mm	CKM20	STCM11	3 mm
MTFNR2525M16	25	25	32,0	150	32,0	TN..160408	ITSN322	KLM34L	2 mm	CKM20	STCM11	3 mm
MTFNR2525M22	25	25	32,0	150	32,0	TN..220408	ITSN433	KLM46	2.5 mm	CKM9	STCM4	4 mm
left hand												
MTFNL2020K16	20	20	25,0	125	32,0	TN..160408	ITSN322	KLM34L	2 mm	CKM20	STCM11	3 mm
MTFNL2525M16	25	25	32,0	150	32,0	TN..160408	ITSN322	KLM34L	2 mm	CKM20	STCM11	3 mm
MTFNL2525M22	25	25	32,0	150	32,0	TN..220408	ITSN433	KLM46	2.5 mm	CKM9	STCM4	4 mm

O.D./I.D. Tooling

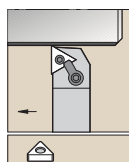

See pages B66–B73 and B179–B180 for inserts.

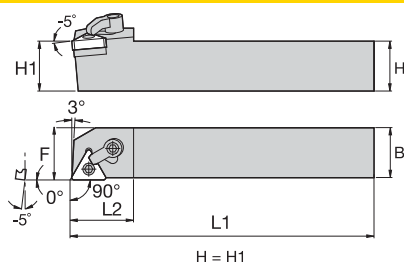

MTGN 90°

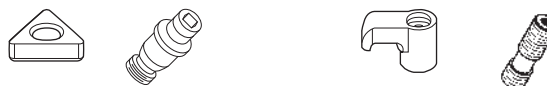

O.D./I.D. Tooling

catalogue number	H	B	F	L1	L2	gage insert	shim	lock pin	hex (mm)	clamp	clamp screw	hex (mm)
right hand												
MTGNR1616H16	16	16	20,0	100	32,0	TN..160408	ITSN322	KLM34L	2 mm	CKM20	STCM11	3 mm
MTGNR2020K16	20	20	25,0	125	32,0	TN..160408	ITSN322	KLM34L	2 mm	CKM21	STCM20	3 mm
MTGNR2525M16	25	25	32,0	150	32,0	TN..160408	ITSN322	KLM34L	2 mm	CKM21	STCM20	3 mm
left hand												
MTGNL2525M16	25	25	32,0	150	32,0	TN..160408	ITSN322	KLM34L	2 mm	CKM21	STCM20	3 mm
MTGNL2525M22	25	25	32,0	150	32,0	TN..220408	ITSN433	KLM46	2.5 mm	CKM9	STCM4	4 mm
MTGNL3232P22	32	32	40,0	170	32,0	TN..220408	ITSN433	KLM46	2.5 mm	CKM9	STCM4	4 mm

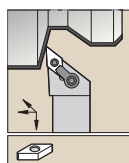

See pages B74–B78 and B180–B181 for inserts.

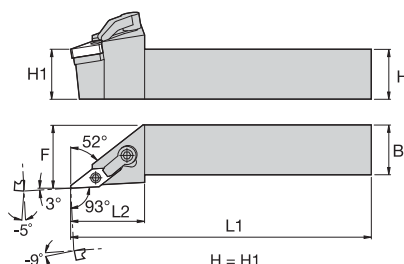

MVJN 93°



catalogue number	H	B	F	L1	L2	gage insert	shim	lock pin	hex (mm)	clamp	clamp screw	hex (mm)
right hand												
MVJNR2020K16	20	20	25,0	125	37,0	VN..160408	IVSN322	KLM34L	2 mm	CKM31	STCM20	3 mm
MVJNR2525M16	25	25	32,0	150	37,0	VN..160408	IVSN322	KLM34L	2 mm	CKM31	STCM20	3 mm
MVJNR3225P16	32	25	32,0	171	37,0	VN..160408	IVSN322	KLM34L	2 mm	CKM31	STCM20	3 mm
MVJNR3225P22	32	25	32,0	170	50,0	VN..220408	IVSN432	KLM46	2.5 mm	CKM26	STCM4	4 mm
MVJNR3232P16	32	32	40,5	171	37,0	VN..160408	IVSN322	KLM34L	2 mm	CKM31	STCM20	3 mm
left hand												
MVJNL2020K16	20	20	25,0	125	37,0	VN..160408	IVSN322	KLM34L	2 mm	CKM31	STCM20	3 mm
MVJNL2525M16	25	25	32,0	150	37,0	VN..160408	IVSN322	KLM34L	2 mm	CKM31	STCM20	3 mm
MVJNL3225P16	32	25	32,0	171	37,0	VN..160408	IVSN322	KLM34L	2 mm	CKM31	STCM20	3 mm
MVJNL3225P22	32	25	32,0	170	50,0	VN..220408	IVSN432	KLM46	2.5 mm	CKM26	STCM4	4 mm
MVJNL3232P16	32	32	40,5	171	37,0	VN..160408	IVSN322	KLM34L	2 mm	CKM31	STCM20	3 mm

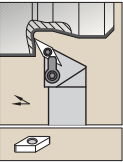

See pages B74–B78 and B180–B181 for inserts.

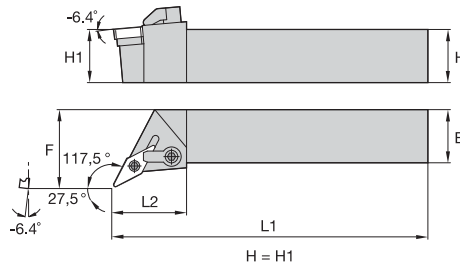

■ **MVON 117,5°**



catalogue number	H	B	F	L1	L2	gage insert	shim	lock pin	hex (mm)	clamp	clamp screw	hex (mm)
right hand												
MVONR2525M16	25	25	32,0	150	30,0	VN..160408	IVSN322	KLM34L	2 mm	CKM6	STCM5	2.5 mm
left hand												
MVONL2525M16	25	25	32,0	150	30,0	VN..160408	IVSN322	KLM34L	2 mm	CKM6	STCM5	2.5 mm

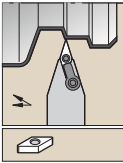

See pages B74–B78 and B180–B181 for inserts.

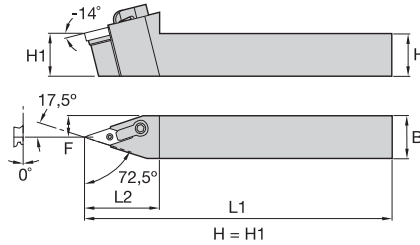

■ **MVVN 72,5°**



catalogue number	H	B	F	L1	L2	gage insert	shim	lock pin	hex (mm)	clamp	clamp screw	hex (mm)
MVVNN2020K16	20	20	10,0	125	42,0	VN..160408	IVSN322	KLM34L	2 mm	CKM31	STCM20	3 mm
MVVNN2525M16	25	25	12,5	150	42,0	VN..160408	IVSN322	KLM34L	2 mm	CKM31	STCM20	3 mm
MVVNN2525M22	25	25	12,0	150	55,0	VN..220408	IVSN432	KLM46	2.5 mm	CKM26	STCM4	4 mm
MVVNN3225P16	32	25	12,5	170	42,0	VN..160408	IVSN322	KLM34L	2 mm	CKM31	STCM20	3 mm

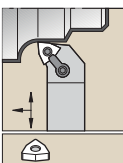

See pages B79–B83 and B181 for inserts.

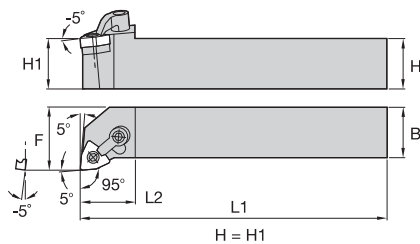

■ **MWLN 95°**



catalogue number	H	B	F	L1	L2	gage insert	shim	lock pin	hex (mm)	clamp	clamp screw	hex (mm)
right hand												
MWLN R2020K06	20	20	25,0	125	25,0	WN..060408	IWSN322	KLM34L	2 mm	CKM6	STCM5	2.5 mm
MWLN R2525M06	25	25	32,0	150	25,0	WN..060408	IWSN322	KLM34L	2 mm	CKM6	STCM5	2.5 mm
MWLN R3232P08	32	32	40,3	171	32,0	WN..080408	IWSN433	KLM46	2.5 mm	CKM7	STCM5	2.5 mm
left hand												
MWLN L2020K06	20	20	25,0	125	25,0	WN..060408	IWSN322	KLM34L	2 mm	CKM6	STCM5	2.5 mm
MWLN L2525M06	25	25	32,0	150	25,0	WN..060408	IWSN322	KLM34L	2 mm	CKM6	STCM5	2.5 mm
MWLN L3232P08	32	32	40,3	171	32,0	WN..080408	IWSN433	KLM46	2.5 mm	CKM7	STCM5	2.5 mm

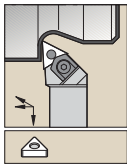

See pages B66–B73 and B179–B180 for inserts.

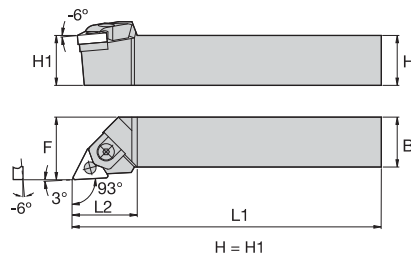

■ MTJN 93°

O.D./I.D. Tooling



catalogue number	H	B	F	L1	L2	gage insert	shim	lock pin	set screw	hex (mm)	clamp assembly	hex (mm)
right hand												
MTJNR2020K16H4	20	20	25,0	125	32,0	TN..160408	512.125	513.125	192.159	3 mm	551.125	3 mm
MTJNR2525M16H4	25	25	32,0	150	32,0	TN..160408	512.125	513.125	192.159	3 mm	551.125	3 mm
MTJNR2525M22H4	25	25	32,0	150	36,0	TN..220408	512.126	513.126	192.159	3 mm	551.126	3 mm
left hand												
MTJNL2020K16H4	20	20	25,0	125	32,0	TN..160408	512.125	513.125	192.159	3 mm	551.125	3 mm
MTJNL2525M16H4	25	25	32,0	150	32,0	TN..160408	512.125	513.125	192.159	3 mm	551.125	3 mm
MTJNL2525M22H4	25	25	32,0	150	36,0	TN..220408	512.126	513.126	192.159	3 mm	551.126	3 mm
MTJNL3225P16H4	32	25	32,0	170	32,0	TN..160408	512.125	513.125	192.159	3 mm	551.125	3 mm

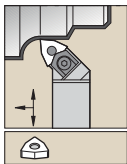

See pages B79–B83 and B181 for inserts.

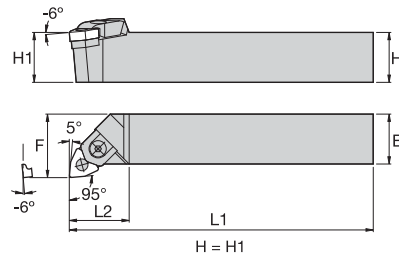

■ MWLN 95°



catalogue number	H	B	F	L1	L2	gage insert	shim	lock pin	set screw	Torx	clamp assembly	hex (mm)
right hand												
MWLN2020K08H4	20	20	25,0	125	30,0	WN..080408	512.131	513.132	192.636	T15	551.131	3 mm
MWLN2525M08H4	25	25	32,0	150	30,0	WN..080408	512.131	513.132	192.636	T15	551.131	3 mm
MWLN3225P08H4	32	25	32,0	170	30,0	WN..080408	512.131	513.132	192.636	T15	551.131	3 mm
left hand												
MWLN2020K08H4	20	20	25,0	125	30,0	WN..080408	512.131	513.132	192.636	T15	551.131	3 mm
MWLN2525M08H4	25	25	32,0	150	30,0	WN..080408	512.131	513.132	192.636	T15	551.131	3 mm
MWLN3225P08H4	32	25	32,0	170	30,0	WN..080408	512.131	513.132	192.636	T15	551.131	3 mm



The ISO 26622 Standard

KM™ Quick Change Tooling — the ISO 26622 Standard.

- Our unique three-surface taper contact design makes this the most rigid and accurate modular quick-change tooling system available.
- It's highly versatile, too: can be fully and easily employed on your lathe, machining centre, multi-spindle, or mill-turn machine — significantly reducing your tool-change and part setup downtime!

Experience the advantages at your Authorised Kennametal Distributor or at www.kennametal.com.

www.kennametal.com



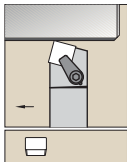

See pages B85–B86 and B130 for inserts.

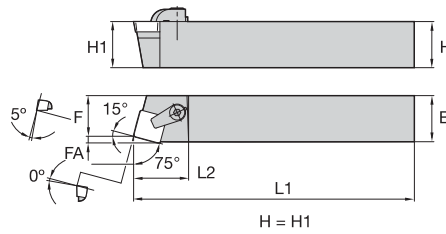

■ **CSBP 75°**

O.D./I.D. Tooling



catalogue number	H	B	F	L1	L2	FA	gage insert	shim	hex (mm)	shim screw	clamp	clamp screw	hex (mm)
right hand													
CSBPR2020K12	20	20	17,0	125	30,0	3,1	SP..120308	SM840	2 mm	MS111	CKM10	STCM8	4 mm
CSBPR2525M12	25	25	22,0	150	30,0	3,1	SP..120308	SM840	2 mm	MS111	CKM10	STCM8	4 mm
left hand													
CSBPL2020K12	20	20	17,0	125	30,0	3,1	SP..120308	SM840	2 mm	MS111	CKM10	STCM8	4 mm
CSBPL2525M12	25	25	22,0	150	30,0	3,1	SP..120308	SM840	2 mm	MS111	CKM10	STCM8	4 mm

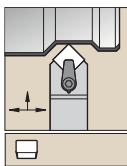

See pages B85–B86 and B130 for inserts.

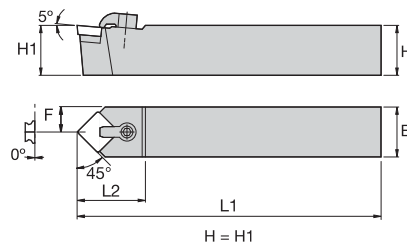

■ **CSDP 45°**



catalogue number	H	B	F	L1	L2	gage insert	shim	shim screw	hex (mm)	clamp	clamp screw	hex (mm)
CSDPN1212F09	12	12	6,0	80	25,0	SP..090308	SM820	MS959	—	CKM7	STCM9	2.5 mm
CSDPN1616H09	16	16	8,0	100	25,0	SP..090308	SM820	MS959	—	CKM7	STCM9	2.5 mm
CSDPN2020K12	20	20	10,0	125	32,0	SP..120308	SM840	MS111	2 mm	CKM10	STCM8	4 mm
CSDPN2525M12	25	25	12,5	150	32,0	SP..120308	SM840	MS111	2 mm	CKM9	STCM4	4 mm

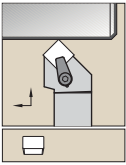

See pages B85–B86 and B130 for inserts.

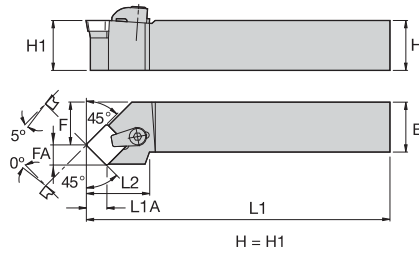
■ CSSP 45°

catalogue number	H	B	F	L1	L2	FA	L1A	gage insert	shim	shim screw	hex (mm)	clamp	clamp screw	hex (mm)
right hand														
CSSPR2020K12	20	20	25,0	125	32,0	8,7	8,3	SP..120308	SM840	MS111	2 mm	CKM10	STCM8	4 mm
left hand														
CSSPR2525M12	25	25	32,0	150	32,0	8,7	8,3	SP..120308	SM840	MS111	2 mm	CKM9	STCM4	4 mm
CSSPL2525M12	25	25	32,0	150	32,0	8,7	8,3	SP..120308	SM840	MS111	2 mm	CKM9	STCM4	4 mm

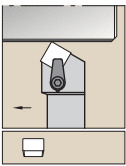

See pages B86–B87 and B130 for inserts.

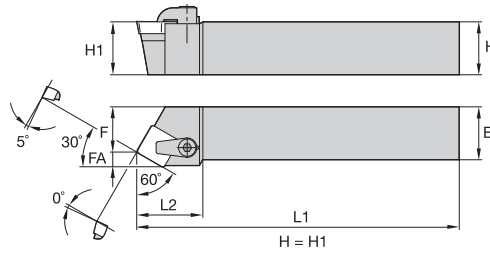

■ CSTP 60°

catalogue number	H	B	F	L1	L2	FA	gage insert	shim	shim screw	hex (mm)	clamp	clamp screw	hex (mm)
right hand													
CSTPR2020K09	20	20	17,0	125	20,0	4,3	SP..090308	SM820	MS959	—	CKM7	STCM5	2.5 mm
left hand													
CSTPR2020K12	20	20	17,0	125	30,0	5,9	SP..120308	SM840	MS111	2 mm	CKM10	STCM8	4 mm
CSTPL2020K09	20	20	17,0	125	20,0	4,3	SP..090308	SM820	MS959	—	CKM7	STCM5	2.5 mm
CSTPL2020K12	20	20	17,0	125	30,0	5,9	SP..120308	SM840	MS111	2 mm	CKM10	STCM8	4 mm
CSTPL2525M12	25	25	22,0	150	28,0	5,9	SP..120308	SM840	MS111	2 mm	CKM12	STCM4	4 mm

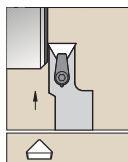
O.D./I.D. Tooling

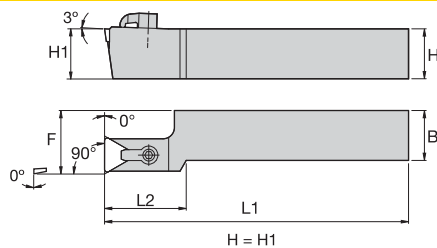

See pages B86–B87 and B130 for inserts.



■ **CTCP 90°**



O.D./I.D. Tooling

catalogue number	H	B	F	L1	L2	gage insert	shim	shim screw	hex (mm)	clamp	clamp screw	hex (mm)
right hand												
CTCPR2020K16	20	20	25,0	125	38,0	TP..160308	SM841	MS111	2 mm	CKM13	STCM8	4 mm

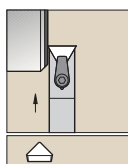

See pages B86–B87 and B130 for inserts.

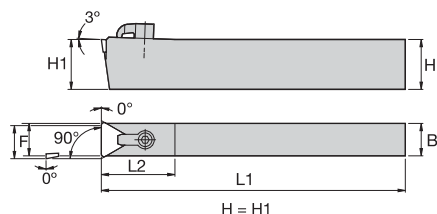

■ **CTCP 90°**



catalogue number	H	B	F	L1	L2	gage insert	shim	shim screw	hex (mm)	clamp	clamp screw	hex (mm)
CTCPN2510M11	25	10	10,0	150	26,0	TP..110304	SM819	MS960	–	CKM7	STCM5	2.5 mm
CTCPN2514M16	25	14	14,4	150	28,0	TP..160308	SM841	MS111	2 mm	CKM13	STCM4	4 mm
CTCPN2518M22	25	18	19,2	150	41,0	TP..220408	SM837	MS125	2.5 mm	CKM13	STCM4	4 mm
CTCPN2520M22	25	20	20,2	150	41,0	TP..220408	SM837	MS125	2.5 mm	CKM13	STCM4	4 mm
CTCPN4018R22	40	18	19,2	200	41,0	TP..220408	SM837	MS125	2.5 mm	CKM13	STCM4	4 mm
CTCPN4020R22	40	20	20,2	200	41,0	TP..220408	SM837	MS125	2.5 mm	CKM13	STCM4	4 mm

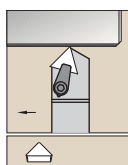

See pages B86–B87 and B130 for inserts.

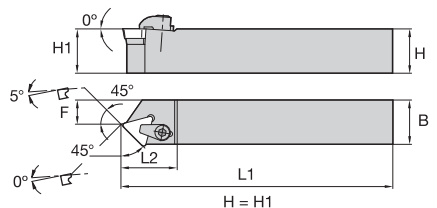

■ **CTDP 45°**



catalogue number	H	B	F	L1	L2	gage insert	shim	shim screw	hex (mm)	clamp	clamp screw	hex (mm)
right hand												
CTDPR1212F11	12	12	6,0	80	22,0	TP..110304	SM819	MS960	–	CKM19	STCM9	2.5 mm
CTDPR2525M16	25	25	16,0	150	30,0	TP..160308	SM841	MS111	2 mm	CKM9	STCM4	4 mm
left hand												
CTDPL1212F11	12	12	6,0	80	22,0	TP..110304	SM819	MS960	–	CKM19	STCM9	2.5 mm

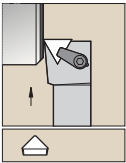

See pages B86–B87 and B130 for inserts.

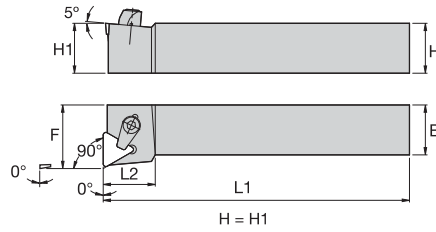

CTFP 90°



catalogue number	H	B	F	L1	L2	gage insert	shim	shim screw	hex (mm)	clamp	clamp screw	hex (mm)
right hand												
CTFPR2020K16	20	20	25,0	125	29,0	TP..160308	SM841	MS111	2 mm	CKM10	STCM8	4 mm
CTFPR2525M16	25	25	32,0	150	29,0	TP..160308	SM841	MS111	2 mm	CKM9	STCM4	4 mm
left hand												
CTFPL2020K16	20	20	25,0	125	29,0	TP..160308	SM841	MS111	2 mm	CKM10	STCM8	4 mm
CTFPL2525M16	25	25	32,0	150	29,0	TP..160308	SM841	MS111	2 mm	CKM9	STCM4	4 mm

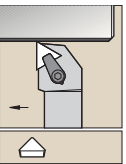

See pages B86–B87 and B130 for inserts.

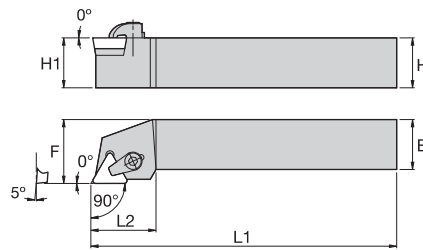

CTGP 90°



catalogue number	H	B	F	L1	L2	gage insert	shim	shim screw	hex (mm)	clamp	clamp screw	hex (mm)
right hand												
CTGPR1212F11	12	12	16,0	80	20,0	TP..110304	SM819	MS960	—	CKM19	STCM9	2.5 mm
CTGPR1616H11	16	16	20,0	100	20,0	TP..110304	SM819	MS960	—	CKM19	STCM9	2.5 mm
CTGPR2020K11	20	20	25,0	125	20,0	TP..110304	SM819	MS960	—	CKM19	STCM9	2.5 mm
CTGPR2020K16	20	20	25,0	125	26,0	TP..160308	SM841	MS111	2 mm	CKM10	STCM8	4 mm
CTGPR2525M16	25	25	32,0	150	26,0	TP..160308	SM841	MS111	2 mm	CKM9	STCM4	4 mm
CTGPR2525M22	25	25	32,0	150	30,0	TP..220408	SM837	MS125	2.5 mm	CKM9	STCM4	4 mm
left hand												
CTGPL1212F11	12	12	16,0	80	20,0	TP..110304	SM819	MS960	—	CKM19	STCM9	2.5 mm
CTGPL2020K16	20	20	25,0	125	26,0	TP..160308	SM841	MS111	2 mm	CKM10	STCM8	4 mm
CTGPL2525M16	25	25	32,0	150	26,0	TP..160308	SM841	MS111	2 mm	CKM9	STCM4	4 mm

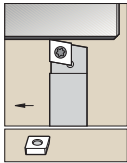

See pages B88–B91 and B187–B188 for inserts.

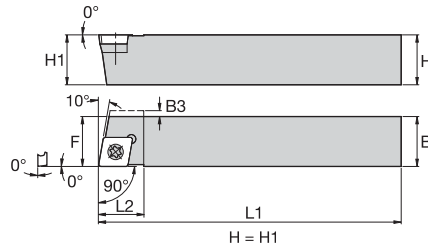

■ SCAC 90°

O.D./I.D. Tooling



catalogue number	H	B	F	L1	L2	B3	gage insert	shim	shim screw	hex	insert screw	Torx
right hand												
SCACR1010M06Q	10	10	10,0	150	11,0	—	CC..060204	—	—	—	MS1153	T7
SCACR1212M06Q	12	12	12,0	150	11,0	—	CC..060204	—	—	—	MS1153	T7
SCACR1616K09Q	16	16	16,0	125	16,0	—	CC..09T308	SKCP343	SRS3	3.5 mm	MS1156	T15
left hand												
SCACL0808M06Q	8	8	8,0	150	12,0	1,5	CC..060204	—	—	—	MS1153	T7
SCACL1010M06Q	10	10	10,0	150	11,0	—	CC..060204	—	—	—	MS1153	T7

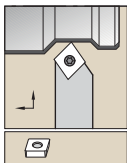

See pages B92–B95 and B189–B190 for inserts.

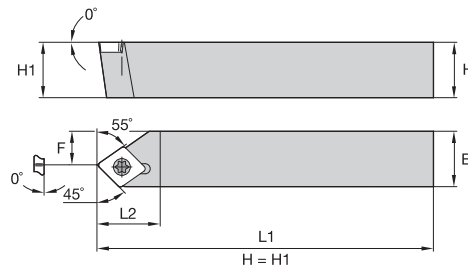

■ SCDP 45°



catalogue number	H	B	F	L1	L2	gage insert	insert screw	Torx
right hand								
SCDPR1212H06	12	12	7,0	100	14,0	CP..060203	MS1153	T7
left hand								
SCDPL1212H06	12	12	7,0	100	14,0	CP..060203	MS1153	T7

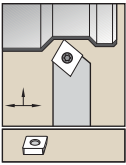

See pages B92–B95 and B189–B190 for inserts.

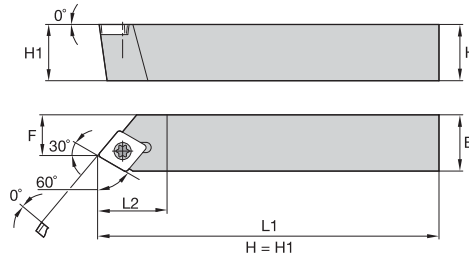

■ SCEP 60°



catalogue number	H	B	F	L1	L2	gage insert	insert screw	Torx
right hand SCEPR1010H06	10	10	6,5	100	12,0	CP..060203R.	MS1153	T7
SCEPR1212H06	12	12	8,5	100	12,0	CP..060203R.	MS1153	T7
left hand SCEPL1010H06	10	10	6,5	100	12,0	CP..060203L.	MS1153	T7

O.D./I.D. Tooling

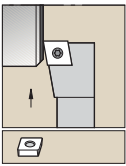

See pages B88–B91 and B187–B188 for inserts.

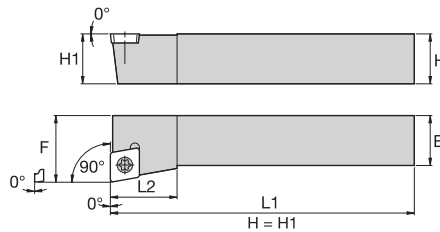

■ SCFC 90°



catalogue number	H	B	F	L1	L2	gage insert	insert screw	Torx
right hand SCFCR1212N09	12	12	16,0	160	16,0	CC..09T308	MS1155	T15
left hand SCFCL1212N09	12	12	16,0	160	16,0	CC..09T308	MS1155	T15

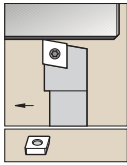

See pages B88–B91 and B187–B188 for inserts.

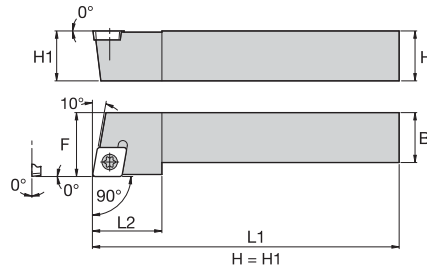

■ SCGC 90°



O.D./I.D. Tooling

catalogue number	H	B	F	L1	L2	gage insert	insert screw	Torx
right hand								
SCGCR1010M06	10	10	12,0	150	11,0	CC..060204	MS1153	T7
SCGCR1212N09	12	12	16,0	160	16,0	CC..09T308	MS1155	T15
left hand								
SCGCL1010M06	10	10	12,0	150	11,0	CC..060204	MS1153	T7
SCGCL1212N09	12	12	16,0	160	16,0	CC..09T308	MS1155	T15

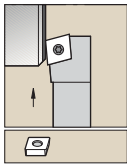

See pages B88–B91 and B187–B188 for inserts.

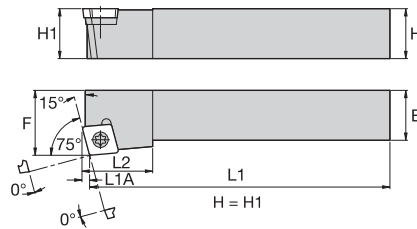

■ SCKC 75°



catalogue number	H	B	F	L1	L2	L1A	gage insert	shim	shim screw	hex	insert screw	Torx
right hand												
SCKCR1616H09	16	16	20,0	100	16,0	2,3	CC..09T308	SKCP343	SRS3	3.5 mm	MS1156	T15
SCKCR2020K09	20	20	25,0	125	16,0	2,3	CC..09T308	SKCP343	SRS3	3.5 mm	MS1156	T15

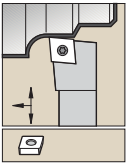

See pages B88–B91 and B187–B188 for inserts.

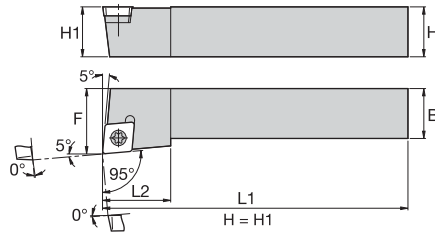

■ SCLC 95°



catalogue number	H	B	F	L1	L2	gage insert	shim	shim screw	hex	insert screw	Torx
right hand											
SCLCR0808L06	8	8	10,0	140	11,0	CC..060204	–	–	–	MS1153	T7
SCLCR1010M06	10	10	12,0	150	12,0	CC..060204	–	–	–	MS1153	T7
SCLCR1212N09	12	12	16,0	160	16,0	CC..09T308	–	–	–	MS1155	T15
SCLCR1616H09	16	16	20,0	100	16,0	CC..09T308	SKCP343	SRS3	3.5 mm	MS1156	T15
SCLCR2020K09	20	20	25,0	125	16,0	CC..09T308	SKCP343	SRS3	3.5 mm	MS1156	T15
SCLCR2020K12	20	20	25,0	125	20,0	CC..120408	SKCP453	SRS4	4 mm	MS1158	T15
SCLCR2525M09	25	25	32,0	150	16,0	CC..09T308	SKCP343	SRS3	3.5 mm	MS1156	T15
SCLCR2525M12	25	25	32,0	150	19,8	CC..120408	SKCP453	SRS4	4 mm	MS1158	T15
left hand											
SCLCL0808L06	8	8	10,0	140	11,0	CC..060204	–	–	–	MS1153	T7
SCLCL1010M06	10	10	12,0	150	12,0	CC..060204	–	–	–	MS1153	T7
SCLCL1212N09	12	12	16,0	160	16,0	CC..09T308	–	–	–	MS1155	T15
SCLCL1616H09	16	16	20,0	100	16,0	CC..09T308	SKCP343	SRS3	3.5 mm	MS1156	T15
SCLCL2020K09	20	20	25,0	125	16,0	CC..09T308	SKCP343	SRS3	3.5 mm	MS1156	T15
SCLCL2020K12	20	20	25,0	125	20,0	CC..120408	SKCP453	SRS4	4 mm	MS1158	T15
SCLCL2525M09	25	25	32,0	150	16,0	CC..09T308	SKCP343	SRS3	3.5 mm	MS1156	T15
SCLCL2525M12	25	25	32,0	150	19,8	CC..120408	SKCP453	SRS4	4 mm	MS1158	T15

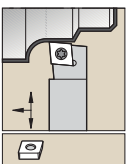

See pages B88–B91 and B187–B188 for inserts.

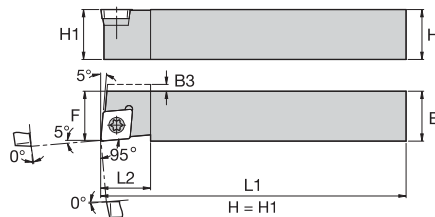

■ SCLC-F 95°



catalogue number	H	B	F	L1	L2	B3	gage insert	shim	shim screw	hex	insert screw	Torx
right hand												
SCLCRF0808M06Q	8	8	8,0	150	12,0	1,5	CC..060204	–	–	–	MS1153	T7
SCLCRF1010M06Q	10	10	10,0	150	11,0	–	CC..060204	–	–	–	MS1153	T7
SCLCRF1212M06Q	12	12	12,0	150	11,0	–	CC..060204	–	–	–	MS1153	T7
SCLCRF1616K09Q	16	16	16,0	125	16,0	–	CC..09T308	SKCP343	SRS3	3.5 mm	MS1156	T15
left hand												
SCLCLF1616K09Q	16	16	16,0	125	16,0	–	CC..09T308	SKCP343	SRS3	3.5 mm	MS1156	T15

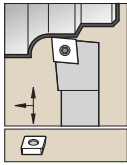

See pages B92–B95 and B189–B190 for inserts.

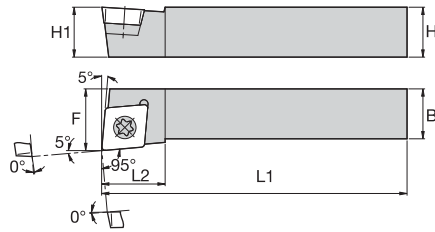

■ SCLP 95°



O.D./I.D. Tooling

catalogue number	H	B	F	L1	L2	gage insert	insert screw	Torx
right hand								
SCLPR1010M06	10	10	11,0	150	11,4	CP..060203	MS1153	T7
SCLPR1212M06	12	12	13,0	150	11,4	CP..060203	MS1153	T7
left hand								
SCLPL1212M06	12	12	13,0	150	11,4	CP..060203	MS1153	T7

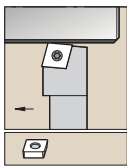

See pages B88–B91 and B187–B188 for inserts.

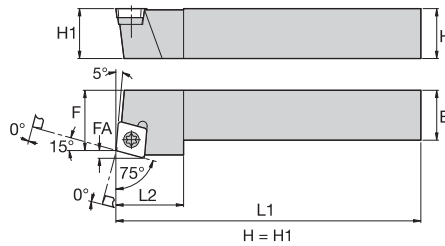

■ SCRC 75°



catalogue number	H	B	F	L1	L2	FA	gage insert	shim	shim screw	hex	insert screw	Torx
right hand												
SCRCR1212N09	12	12	13,0	160	14,0	2,3	CC..09T308	—	—	—	MS1155	T15
SCRCR1616H09	16	16	17,0	100	14,0	2,3	CC..09T308	SKCP343	SRS3	3.5 mm	MS1156	T15

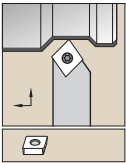

See pages B92–B95 and B189–B190 for inserts.

■ SCSP 45°

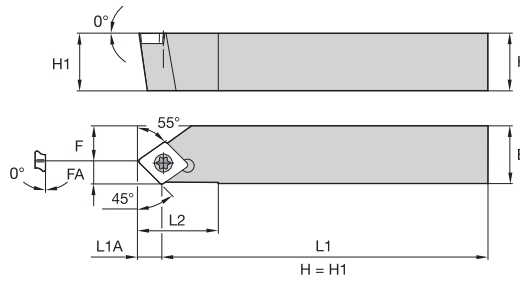

catalogue number	H	B	F	L1	L2	FA	L1A	gage insert	shim	shim screw	hex	insert screw	Torx
SCSPR1010H06	10	10	6,0	100	14,0	4,2	4,2	CP..060203	—	—	—	MS1153	T7

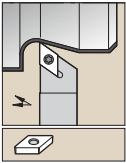

See pages B95–B98 and B191–B192 for inserts.

■ SDAC 90°

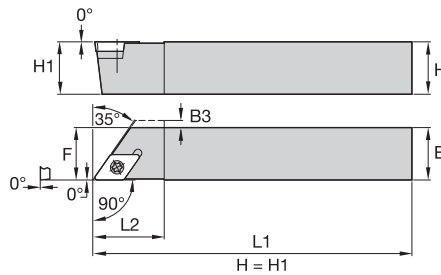

catalogue number	H	B	F	L1	L2	B3	gage insert	shim	shim screw	hex	insert screw	Torx
right hand SDACR1212M11Q	12	12	12,0	150	22,0	1,5	DC..11T308	—	—	—	MS1155	T15
SDACR1616K11Q left hand	16	16	16,0	125	22,0	—	DC..11T308	SKDP343	SRS3	3.5 mm	MS1156	T15
SDACL0808M07Q	8	8	8,0	150	16,0	1,5	DC..070204	—	—	—	MS1153	T7
SDACL1212M11Q	12	12	12,0	150	22,0	1,5	DC..11T308	—	—	—	MS1155	T15

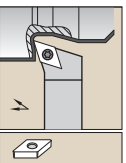

See pages B95–B98 and B191–B192 for inserts.

■ SDHC 107,5°

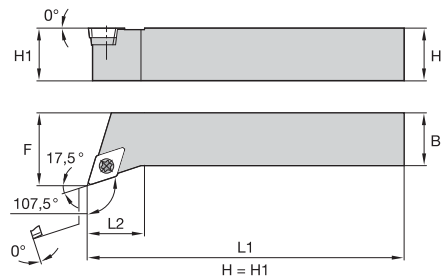

catalogue number	H	B	F	L1	L2	gage insert	shim	shim screw	hex	insert screw	Torx
right hand SDHCR1616H11	16	16	20,0	100	20,0	DC..11T308	SKDP343	SRS3	3.5 mm	MS1156	T15
SDHCR2020K11	20	20	25,0	125	20,0	DC..11T308	SKDP343	SRS3	3.5 mm	MS1156	T15
SDHCR2525M11	25	25	32,0	150	20,0	DC..11T308	SKDP343	SRS3	3.5 mm	MS1156	T15
SDHCR2525M15 left hand	25	25	32,0	150	25,0	DC..150408	SKDP453	SRS4	4 mm	MS1158	T15
SDHCL1616H11	16	16	20,0	100	20,0	DC..11T308	SKDP343	SRS3	3.5 mm	MS1156	T15
SDHCL2020K11	20	20	25,0	125	20,0	DC..11T308	SKDP343	SRS3	3.5 mm	MS1156	T15
SDHCL2525M11	25	25	32,0	150	20,0	DC..11T308	SKDP343	SRS3	3.5 mm	MS1156	T15
SDHCL2525M15	25	25	32,0	150	25,0	DC..150408	SKDP453	SRS4	4 mm	MS1158	T15

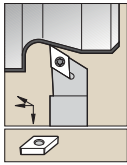

See pages B95–B98 and B191–B192 for inserts.

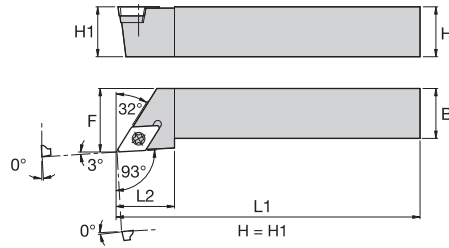

SDJC 93°

O.D./I.D. Tooling



catalogue number	H	B	F	L1	L2	gage insert	shim	shim screw	hex	insert screw	Torx
right hand											
SDJCR0808L07	8	8	10,0	140	16,0	DC..070204	—	—	—	MS1153	T7
SDJCR1010M07	10	10	12,0	150	16,0	DC..070204	—	—	—	MS1153	T7
SDJCR1212N07	12	12	16,0	160	16,0	DC..070204	—	—	—	MS1153	T7
SDJCR1212N11	12	12	16,0	160	22,0	DC..11T308	—	—	—	MS1155	T15
SDJCR1616H07	16	16	20,0	100	16,0	DC..070204	—	—	—	MS1153	T7
SDJCR1616H11	16	16	20,0	100	22,0	DC..11T308	SKDP343	SRS3	3.5 mm	MS1156	T15
SDJCR2020K07	20	20	25,0	125	16,0	DC..070204	—	—	—	MS1153	T7
SDJCR2020K11	20	20	25,0	125	22,0	DC..11T308	SKDP343	SRS3	3.5 mm	MS1156	T15
SDJCR2020K15	20	20	25,0	125	32,0	DC..150408	SKDP453	SRS4	4 mm	MS1158	T15
SDJCR2525M11	25	25	32,0	150	22,0	DC..11T308	SKDP343	SRS3	3.5 mm	MS1156	T15
SDJCR2525M15	25	25	32,0	150	32,0	DC..150408	SKDP453	SRS4	4 mm	MS1158	T15
left hand											
SDJCL0808L07	8	8	10,0	140	16,0	DC..070204	—	—	—	MS1153	T7
SDJCL1010M07	10	10	12,0	150	16,0	DC..070204	—	—	—	MS1153	T7
SDJCL1212N07	12	12	16,0	160	16,0	DC..070204	—	—	—	MS1153	T7
SDJCL1212N11	12	12	16,0	160	22,0	DC..11T308	—	—	—	MS1155	T15
SDJCL1616H07	16	16	20,0	100	16,0	DC..070204	—	—	—	MS1153	T7
SDJCL1616H11	16	16	20,0	100	22,0	DC..11T308	SKDP343	SRS3	3.5 mm	MS1156	T15
SDJCL2020K07	20	20	25,0	125	16,0	DC..070204	—	—	—	MS1153	T7
SDJCL2020K11	20	20	25,0	125	22,0	DC..11T308	SKDP343	SRS3	3.5 mm	MS1156	T15
SDJCL2525M11	25	25	32,0	150	22,0	DC..11T308	SKDP343	SRS3	3.5 mm	MS1156	T15
SDJCL2525M15	25	25	32,0	150	32,0	DC..150408	SKDP453	SRS4	4 mm	MS1158	T15

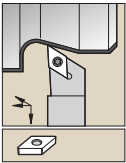

See pages B95–B98 and B191–B192 for inserts.

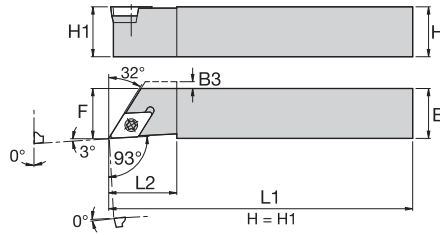

■ SDJC-F 93°



catalogue number	H	B	F	L1	L2	B3	gage insert	shim	shim screw	hex	insert screw	Torx
right hand												
SDJCRF0808M07Q	8	8	8,0	150	16,0	1,5	DC..070204	—	—	—	MS1153	T7
SDJCRF1010M07Q	10	10	10,0	150	16,0	—	DC..070204	—	—	—	MS1153	T7
SDJCRF1212M07Q	12	12	12,0	150	16,0	—	DC..070204	—	—	—	MS1153	T7
left hand												
SDJCLF1212M07Q	12	12	12,0	150	16,0	—	DC..070204	—	—	—	MS1153	T7
SDJCLF1616K11Q	16	16	16,0	125	22,0	—	DC..11T308	SKDP343	SRS3	3.5 mm	MS1156	T15

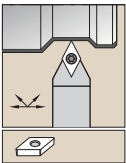

See pages B95–B98 and B191–B192 for inserts.

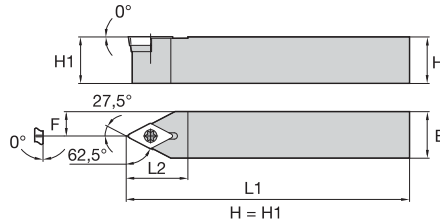

■ SDNC 62,5°



catalogue number	H	B	F	L1	L2	gage insert	shim	shim screw	hex	insert screw	Torx
SDNCN0808L07	8	8	4,0	140	16,0	DC..070204	—	—	—	MS1153	T7
SDNCN1010M07	10	10	5,0	150	16,0	DC..070204	—	—	—	MS1153	T7
SDNCN1212N07	12	12	6,0	160	16,0	DC..070204	—	—	—	MS1153	T7
SDNCN1616H11	16	16	8,0	100	22,0	DC..11T308	SKDP343	SRS3	3.5 mm	MS1156	T15
SDNCN2020K11	20	20	10,0	125	22,0	DC..11T308	SKDP343	SRS3	3.5 mm	MS1156	T15
SDNCN2020K15	20	20	10,0	125	28,0	DC..150408	SKDP453	SRS4	4 mm	MS1158	T15
SDNCN2525M15	25	25	12,5	150	28,0	DC..150408	SKDP453	SRS4	4 mm	MS1158	T15

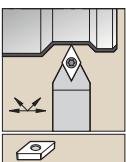

See pages B95–B98 and B191–B192 for inserts.

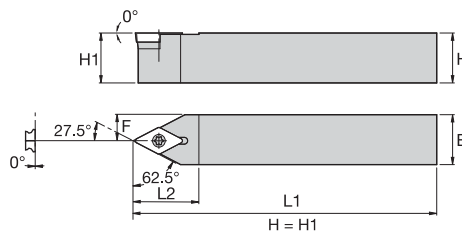

■ SDPC 62,5°



catalogue number	H	B	F	L1	L2	gage insert	shim	shim screw	hex	insert screw	Torx
SDPCN1212M11Q	12	12	6,0	150	22,0	DC..11T308	—	—	—	MS1155	T15
SDPCN1616K11Q	16	16	8,0	125	22,0	DC..11T308	SKDP343	SRS3	3.5 mm	MS1156	T15

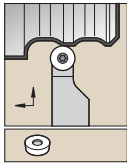

See pages B100–B102 for inserts.

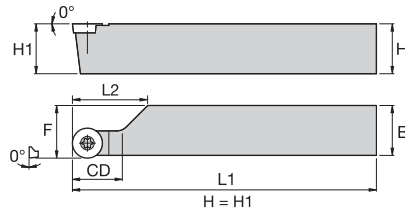

SRAC

O.D./I.D. Tooling



catalogue number	H	B	F	L1	L2	CD	gage insert	insert screw	Torx
right hand									
SRACR1010M06	10	10	11,0	150	29,0	10,0	RC..0602M0	MS1153	T7
SRACR1212N08	12	12	13,0	160	31,0	12,0	RC..0803M0	MS1154	T9
SRACR1616Q08	16	16	17,0	180	35,0	16,0	RC..0803M0	MS1154	T9
left hand									
SRACL1616Q08	16	16	17,0	180	35,0	16,0	RC..0803M0	MS1154	T9

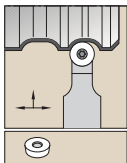

See pages B100–B102 for inserts.

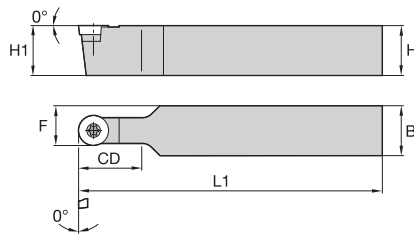

SRDC



catalogue number	H	B	F	L1	CD	gage insert	shim	shim screw	hex	insert screw	Torx
SRDCN0808L06	8	8	7,0	140	8,0	RC..0602M0	—	—	—	MS1153	T7
SRDCN1010M06	10	10	8,0	150	10,0	RC..0602M0	—	—	—	MS1153	T7
SRDCN1212N06	12	12	9,0	160	12,0	RC..0602M0	—	—	—	MS1153	T7
SRDCN1212N08	12	12	10,0	160	12,0	RC..0803M0	—	—	—	MS1154	T9
SRDCN1616H06	16	16	11,0	100	16,0	RC..0602M0	—	—	—	MS1153	T7
SRDCN1616H08	16	16	12,0	100	16,0	RC..0803M0	—	—	—	MS1154	T9
SRDCN1616H10	16	16	13,0	100	16,0	RC..10T3M0	SKRN100300	SRS3	3.5 mm	MS1156	T15
SRDCN1616Q08	16	16	12,0	180	16,0	RC..0803M0	—	—	—	MS1154	T9
SRDCN2020K08	20	20	14,0	125	20,0	RC..0803M0	—	—	—	MS1154	T9
SRDCN2020K10	20	20	15,0	125	20,0	RC..10T3M0	SKRN100300	SRS3	3.5 mm	MS1156	T15
SRDCN2020K12	20	20	16,0	125	20,0	RC..1204M0	SKRN1203M0	SRS3	3.5 mm	MS1156	T15
SRDCN2525M08	25	25	16,5	150	25,0	RC..0803M0	—	—	—	MS1154	T9
SRDCN2525M10	25	25	17,5	150	25,0	RC..10T3M0	SKRN100300	SRS3	3.5 mm	MS1156	T15
SRDCN2525M12	25	25	18,5	150	25,0	RC..1204M0	SKRN1203M0	SRS3	3.5 mm	MS1156	T15
SRDCN2525M16	25	25	20,5	150	25,0	RC..1605M0	SKRN160400	SRS4	4 mm	—	T15

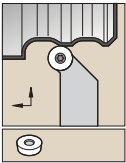

See pages B100–B102 for inserts.

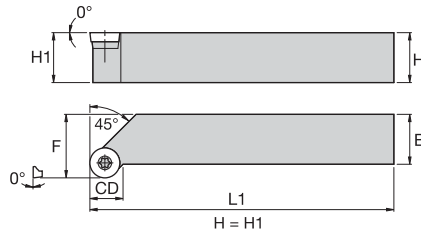

■ SRGC

catalogue number	H	B	F	L1	CD	gage insert					Torx
							shim	shim screw	hex	insert screw	
right hand											
SRGCR1616H06	16	16	20,0	100	7,0	RC..0602M0	—	—	—	MS1153	T7
SRGCR1616H10	16	16	20,0	100	7,9	RC..10T3M0	SKRN100300	SRS3	3.5 mm	MS1156	T15
SRGCR2020K08	20	20	25,0	125	9,0	RC..0803M0	—	—	—	MS1154	T9
SRGCR2020K10	20	20	25,0	125	9,3	RC..10T3M0	SKRN100300	SRS3	3.5 mm	MS1156	T15
SRGCR2525M08	25	25	32,0	150	11,8	RC..0803M0	—	—	—	MS1154	T9
SRGCR2525M10	25	25	32,0	150	12,1	RC..10T3M0	SKRN100300	SRS3	3.5 mm	MS1156	T15
SRGCR2525M12	25	25	32,0	150	12,7	RC..1204M0	SKRN1203M0	SRS3	3.5 mm	MS1156	T15
left hand											
SRGCL1616H06	16	16	20,0	100	7,0	RC..0602M0	—	—	—	MS1153	T7
SRGCL1616H10	16	16	20,0	100	7,9	RC..10T3M0	SKRN100300	SRS3	3.5 mm	MS1156	T15
SRGCL2020K08	20	20	25,0	125	9,0	RC..0803M0	—	—	—	MS1154	T9
SRGCL2525M08	25	25	32,0	150	11,8	RC..0803M0	—	—	—	MS1154	T9
SRGCL2525M10	25	25	32,0	150	12,1	RC..10T3M0	SKRN100300	SRS3	3.5 mm	MS1156	T15
SRGCL2525M12	25	25	32,0	150	12,7	RC..1204M0	SKRN1203M0	SRS3	3.5 mm	MS1156	T15

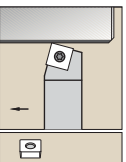

See pages B103–B104 for inserts.

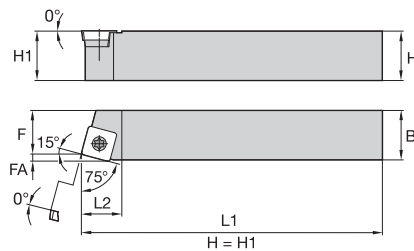

■ SSBC 75°

catalogue number	H	B	F	L1	L2	FA	gage insert					Torx
								shim	shim screw	hex	insert screw	
right hand												
SSBCR1212N09	12	12	11,0	160	16,0	2,2	SC..09T308	—	—	—	MS1155	T15
SSBCR2020K12	20	20	17,0	125	21,0	3,1	SC..120408	SKSP453	SRS4	4 mm	MS1158	T15
SSBCR2525M12	25	25	22,0	150	21,0	3,1	SC..120408	SKSP453	SRS4	4 mm	MS1158	T15
left hand												
SSBCL1616H09	16	16	13,0	100	16,0	2,2	SC..09T308	SKSP343	SRS3	3.5 mm	MS1156	T15



O.D./I.D. Tooling

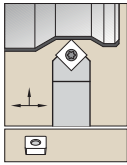

See pages B103–B104 for inserts.

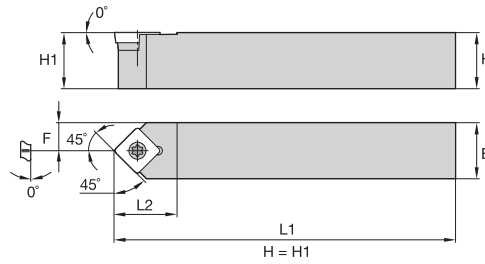

■ **SSDC 45°**

O.D./I.D. Tooling



catalogue number	H	B	F	L1	L2	gage insert	shim	shim screw	hex	insert screw	Torx
SSDCN1212N09	12	12	6,0	160	18,0	SC..09T308	—	—	—	MS1155	T15
SSDCN1616H09	16	16	8,0	100	18,0	SC..09T308	SKSP343	SRS3	3.5 mm	MS1156	T15
SSDCN2020K09	20	20	10,0	125	18,0	SC..09T308	SKSP343	SRS3	3.5 mm	MS1156	T15

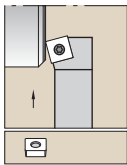

See pages B103–B104 for inserts.

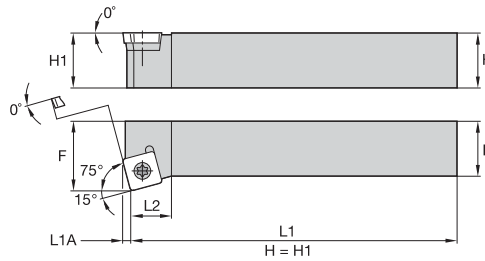

■ **SSKC 75°**



catalogue number	H	B	F	L1	L2	L1A	gage insert	shim	shim screw	hex	insert screw	Torx
right hand												
SSKCR1616H09	16	16	20,0	100	16,0	2,2	SC..09T308	SKSP343	SRS3	3.5 mm	MS1156	T15
SSKCR2020K12	20	20	25,0	125	22,0	3,1	SC..120408	SKSP453	SRS4	4 mm	MS1158	T15
left hand												
SSKCL2020K12	20	20	25,0	125	22,0	3,1	SC..120408	SKSP453	SRS4	4 mm	MS1158	T15

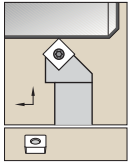

See pages B103–B104 for inserts.

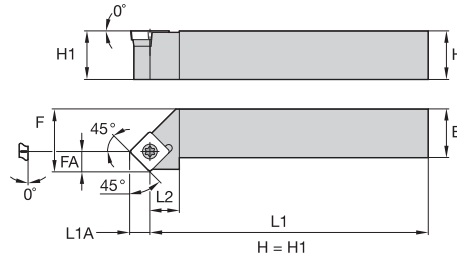

■ SSSC 45°



catalogue number	H	B	F	L1	L2	FA	L1A	gage insert	shim	shim screw	hex	insert screw	Torx
right hand													
SSSCR1212N09	12	12	16,0	160	18,0	6,1	6,1	SC..09T308	—	—	—	MS1155	T15
SSSCR1616H09	16	16	20,0	100	18,0	6,1	6,1	SC..09T308	SKSP343	SRS3	3.5 mm	MS1156	T15
SSSCR1616H12	16	16	20,0	100	25,0	8,3	8,3	SC..120408	SKSP453	SRS4	4 mm	MS1158	T15
SSSCR2020K12	20	20	25,0	125	25,0	8,3	8,3	SC..120408	SKSP453	SRS4	4 mm	MS1158	T15
SSSCR2525M12	25	25	32,0	150	25,0	8,3	8,3	SC..120408	SKSP453	SRS4	4 mm	MS1158	T15
left hand													
SSSCL1212N09	12	12	16,0	160	18,0	6,1	6,1	SC..09T308	—	—	—	MS1155	T15
SSSCL1616H09	16	16	20,0	100	18,0	6,1	6,1	SC..09T308	SKSP343	SRS3	3.5 mm	MS1156	T15
SSSCL1616H12	16	16	20,0	100	25,0	8,3	8,3	SC..120408	SKSP453	SRS4	4 mm	MS1158	T15
SSSCL2020K12	20	20	25,0	125	25,0	8,3	8,3	SC..120408	SKSP453	SRS4	4 mm	MS1158	T15
SSSCL2525M12	25	25	32,0	150	25,0	8,3	8,3	SC..120408	SKSP453	SRS4	4 mm	MS1158	T15

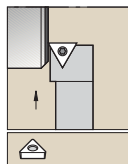

See pages B106–B108 and B194–B195 for inserts.

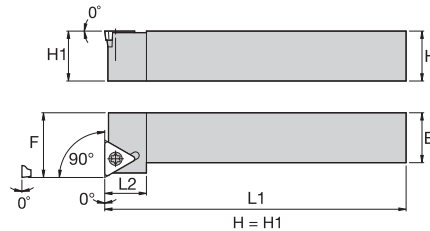

■ STFC 90°



catalogue number	H	B	F	L1	L2	gage insert	shim	shim screw	hex	insert screw	Torx
right hand											
STFCR1616H11	16	16	20,0	100	16,0	TC..110204	—	—	—	MS1153	T7
STFCR1616H16	16	16	20,0	100	20,0	TC..16T308	SKTP343	SRS3	3.5 mm	MS1156	T15
STFCR2020K16	20	20	25,0	125	20,0	TC..16T308	SKTP343	SRS3	3.5 mm	MS1156	T15
STFCR2525M16	25	25	32,0	150	20,0	TC..16T308	SKTP343	SRS3	3.5 mm	MS1156	T15
left hand											
STFCL1010M11	10	10	12,0	150	13,0	TC..110204	—	—	—	MS1153	T7
STFCL1212N11	12	12	16,0	160	13,0	TC..110204	—	—	—	MS1153	T7
STFCL1616H16	16	16	20,0	100	20,0	TC..16T308	SKTP343	SRS3	3.5 mm	MS1156	T15
STFCL2020K16	20	20	25,0	125	20,0	TC..16T308	SKTP343	SRS3	3.5 mm	MS1156	T15
STFCL2525M16	25	25	32,0	150	20,0	TC..16T308	SKTP343	SRS3	3.5 mm	MS1156	T15

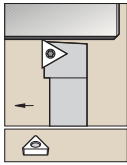

See pages B106–B108 and B194–B195 for inserts.

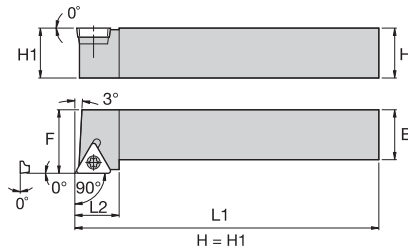

■ STGC 90°

O.D./I.D. Tooling



catalogue number	H	B	F	L1	L2	gage insert	shim	shim screw	hex	insert screw	Torx
right hand											
STGCR1010M11	10	10	12,0	150	16,0	TC..110204	–	–	–	MS1153	T7
STGCR1212N11	12	12	16,0	160	16,0	TC..110204	–	–	–	MS1153	T7
STGCR1616H11	16	16	20,0	100	20,0	TC..110204	–	–	–	MS1153	T7
STGCR1616H16	16	16	20,0	100	20,0	TC..16T308	SKTP343	SRS3	3.5 mm	MS1156	T15
STGCR2020K16	20	20	25,0	125	20,0	TC..16T308	SKTP343	SRS3	3.5 mm	MS1156	T15
STGCR2525M16	25	25	32,0	150	20,0	TC..16T308	SKTP343	SRS3	3.5 mm	MS1156	T15
left hand											
STGCL1010M11	10	10	12,0	150	16,0	TC..110204	–	–	–	MS1153	T7
STGCL1212N11	12	12	16,0	160	16,0	TC..110204	–	–	–	MS1153	T7
STGCL1616H11	16	16	20,0	100	20,0	TC..110204	–	–	–	MS1153	T7
STGCL1616H16	16	16	20,0	100	20,0	TC..16T308	SKTP343	SRS3	3.5 mm	MS1156	T15
STGCL2020K16	20	20	25,0	125	20,0	TC..16T308	SKTP343	SRS3	3.5 mm	MS1156	T15
STGCL2525M16	25	25	32,0	150	20,0	TC..16T308	SKTP343	SRS3	3.5 mm	MS1156	T15

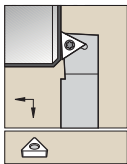

See pages B106–B108 and B194–B195 for inserts.

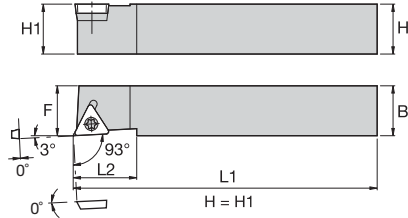

■ STJC-F 90°



catalogue number	H	B	F	L1	L2	gage insert	insert screw	Torx
right hand								
STJCRF1212M11Q	12	12	12,0	150	16,0	TC..110204	MS1153	T7
left hand								
STJCLF1212M11Q	12	12	12,0	150	16,0	TC..110204	MS1153	T7

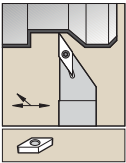

See pages B113–B114 and B196–B197 for inserts.

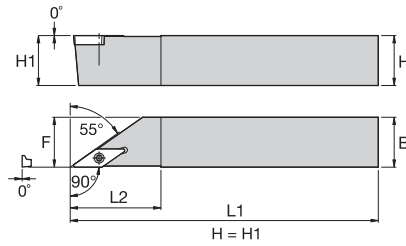

■ SVAB 90°



catalogue number	H	B	F	L1	L2	gage insert	insert screw	Torx
right hand								
SVABR1010M11Q	10	10	10,0	150	22,0	VB..110304	MS1153	T7
SVABR1212M11Q	12	12	12,0	150	22,0	VB..110304	MS1153	T7
SVABR1616K16Q	16	16	16,0	125	30,0	VB..160408	MS1155	T15
left hand								
SVABL1212M11Q	12	12	12,0	150	22,0	VB..110304	MS1153	T7
SVABL1616K16Q	16	16	16,0	125	30,0	VB..160408	MS1155	T15

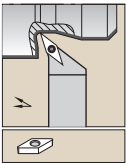

See pages B113–B114 and B196–B197 for inserts.

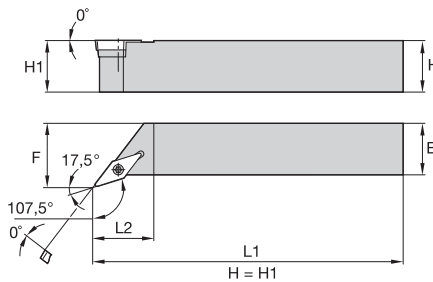

■ SVHB 107,5°



catalogue number	H	B	F	L1	L2	gage insert	shim	shim screw	hex	insert screw	Torx
right hand											
SVHBR1212N11	12	12	16,0	160	19,0	VB..110304	–	–	–	MS1153	T7
SVHBR1616H11	16	16	20,0	100	19,0	VB..110304	–	–	–	MS1153	T7
SVHBR2020K11	20	20	25,0	125	26,0	VB..110304	–	–	–	MS1153	T7
SVHBR2020K16	20	20	25,0	125	28,0	VB..160408	SKVN343	SRS3	3.5 mm	MS1156	T15
SVHBR2525M16	25	25	32,0	150	28,0	VB..160408	SKVN343	SRS3	3.5 mm	MS1156	T15
left hand											
SVHBL1212N11	12	12	16,0	160	19,0	VB..110304	–	–	–	MS1153	T7
SVHBL1616H11	16	16	20,0	100	19,0	VB..110304	–	–	–	MS1153	T7
SVHBL2020K11	20	20	25,0	125	26,0	VB..110304	–	–	–	MS1153	T7
SVHBL2020K16	20	20	25,0	125	28,0	VB..160408	SKVN343	SRS3	3.5 mm	MS1156	T15
SVHBL2525M16	25	25	32,0	150	28,0	VB..160408	SKVN343	SRS3	3.5 mm	MS1156	T15

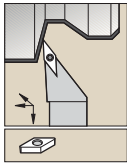

See pages B113–B114 and B196–B197 for inserts.

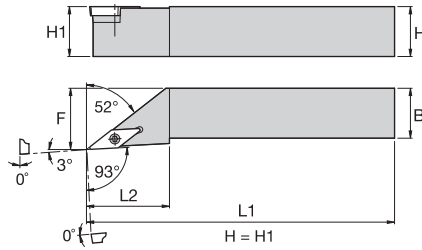

SVJB 93°



O.D./I.D. Tooling

catalogue number	H	B	F	L1	L2	gage insert	shim	shim screw	hex	insert screw	Torx
right hand											
SVJBR1212N11	12	12	16,0	160	22,0	VB..110304	—	—	—	MS1153	T7
SVJBR1616H11	16	16	20,0	100	22,0	VB..110304	—	—	—	MS1153	T7
SVJBR1616H16	16	16	20,0	100	35,0	VB..160408	SKVN343	SRS3	3.5 mm	MS1156	T15
SVJBR2020K11	20	20	25,0	125	26,0	VB..110304	—	—	—	MS1153	T7
SVJBR2020K16	20	20	25,0	125	35,0	VB..160408	SKVN343	SRS3	3.5 mm	MS1156	T15
SVJBR2525M16	25	25	32,0	150	35,0	VB..160408	SKVN343	SRS3	3.5 mm	MS1156	T15
SVJBR3225P16	32	25	32,0	170	35,0	VB..160408	SKVN343	SRS3	3.5 mm	MS1156	T15
left hand											
SVJBL1212N11	12	12	16,0	160	22,0	VB..110304	—	—	—	MS1153	T7
SVJBL1616H11	16	16	20,0	100	22,0	VB..110304	—	—	—	MS1153	T7
SVJBL1616H16	16	16	20,0	100	35,0	VB..160408	SKVN343	SRS3	3.5 mm	MS1156	T15
SVJBL2020K11	20	20	25,0	125	26,0	VB..110304	—	—	—	MS1153	T7
SVJBL2020K16	20	20	25,0	125	35,0	VB..160408	SKVN343	SRS3	3.5 mm	MS1156	T15
SVJBL2525M16	25	25	32,0	150	35,0	VB..160408	SKVN343	SRS3	3.5 mm	MS1156	T15
SVJBL3225P16	32	25	32,0	170	35,0	VB..160408	SKVN343	SRS3	3.5 mm	MS1156	T15

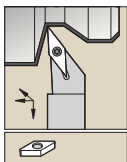

See pages B113–B114 and B196–B197 for inserts.

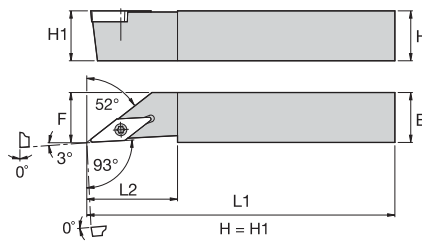

SVJB-F 93°



catalogue number	H	B	F	L1	L2	gage insert	insert screw	Torx
right hand								
SVJBRF1010M11Q	10	10	10,0	150	23,0	VB..110304	MS1153	T7
SVJBRF1212M11Q	12	12	12,0	150	23,0	VB..110304	MS1153	T7
SVJBRF1616K16Q	16	16	16,0	125	31,0	VB..160408	MS1155	T15
left hand								
SVJBLF1010M11Q	10	10	10,0	150	23,0	VB..110304	MS1153	T7
SVJBLF1212M11Q	12	12	12,0	150	23,0	VB..110304	MS1153	T7
SVJBLF1616K16Q	16	16	16,0	125	31,0	VB..160408	MS1155	T15

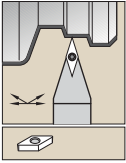

See pages B113–B114 and B196–B197 for inserts.

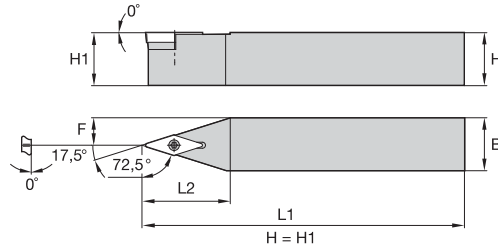

■ SVVB 72,5°



catalogue number	H	B	F	L1	L2	gage insert	shim	shim screw	hex	insert screw	Torx
SVVBN1212N11	12	12	6,0	160	26,0	VB..110304	—	—	—	MS1153	T7
SVVBN1616H11	16	16	8,0	100	26,0	VB..110304	—	—	—	MS1153	T7
SVVBN1616H16	16	16	8,0	100	33,0	VB..160408	SKVN343	SRS3	3.5 mm	MS1156	T15
SVVBN2020K11	20	20	10,0	125	26,0	VB..110304	—	—	—	MS1153	T7
SVVBN2020K16	20	20	10,0	125	33,0	VB..160408	SKVN343	SRS3	3.5 mm	MS1156	T15
SVVBN2525M16	25	25	12,5	150	33,0	VB..160408	SKVN343	SRS3	3.5 mm	MS1156	T15
SVVBN3225P16	32	25	12,5	170	33,0	VB..160408	SKVN343	SRS3	3.5 mm	MS1156	T15

O.D./I.D. Tooling

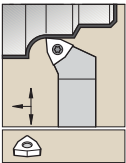

See pages B114–B115 for inserts.

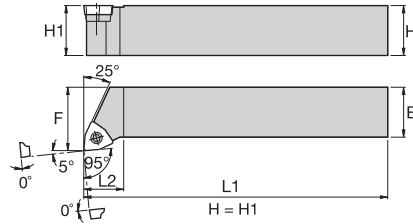

■ SWLC 95°



catalogue number	H	B	F	L1	L2	gage insert	shim	shim screw	hex	insert screw	Torx
right hand											
SWLCR1212N06	12	12	16,0	160	16,0	WC..06T308	SKWP343	SRS3	3.5 mm	MS1156	T15
SWLCR2020K06	20	20	25,0	125	16,0	WC..06T308	SKWP343	SRS3	3.5 mm	MS1156	T15
left hand											
SWLCL2020K06	20	20	25,0	125	16,0	WC..06T308	SKWP343	SRS3	3.5 mm	MS1156	T15

V-Bottom Round Toolholders

Kendex™ Positive Inserts

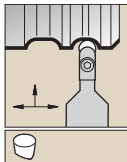

See pages B85 and B129 for inserts.

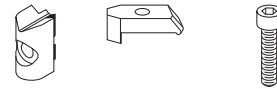
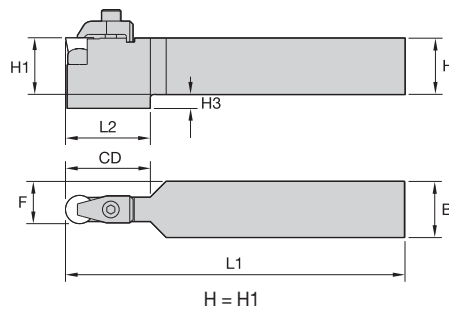

CRDP

O.D./I.D. Tooling

catalogue number	H	B	F	L1	L2	CD	H3	gage insert	nest	clamp	clamp screw	hex
CRDPN2525M06V	25	25	12,5	151,3	—	19,0	—	RPGX060400E	NST1	CM214	MS1321	2.5 mm
CRDPN3232P09V	32	32	16,0	171,3	—	29,0	—	RPGX090700E	NST2	CM219	CS412	3.5 mm
CRDPN2525M09V	25	25	12,5	151,3	—	29,0	—	RPGX090700E	NST2	CM219	CS412	3.5 mm
CRDPN3232P12V	32	32	16,0	171,3	—	38,0	—	RPGX120700E	NST3	CM216	CS412	3.5 mm
CRDPN2525M12V	25	25	12,5	151,3	38,1	38,0	6,4	RPGX120700E	NST3	CM216	CS412	3.5 mm
CRDPN3232P15V	32	32	16,0	171,3	38,1	38,0	6,4	RPGX151000	NST4	CM217	MS1294	6 mm
CRDPN4040R19V	40	40	20,0	201,5	—	38,0	—	RPGX191000	NST5	CM217	MS1294	6 mm
CRDPN3232P19V	32	32	16,0	171,3	38,1	38,0	6,4	RPGX191000	NST5	CM217	MS1294	6 mm
CRDPN3232P25V	32	32	16,0	171,3	38,0	38,0	6,4	RPGX251200	NST6	CM218	MS1242	8 mm

NOTE: CRDP Toolholders are able to use RPGX and RCGX insert styles.

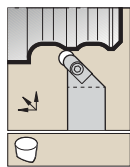

See pages B85 and B129 for inserts.

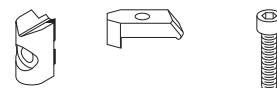
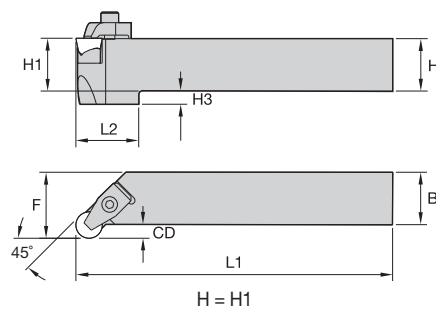

CRGP

catalogue number	H	B	F	L1	L2	H3	CD	gage insert	nest	clamp	clamp screw	hex
right hand												
CRGPR2525M06V	25	25	32,0	151,3	—	—	7,0	RPGX060400E	NST1	CM214	MS1321	2.5 mm
CRGPR3232P09V	32	32	40,0	171,3	—	—	8,0	RPGX090700E	NST2	CM219	CS412	3.5 mm
CRGPR2525M09V	25	25	32,0	151,3	—	—	7,0	RPGX090700E	NST2	CM219	CS412	3.5 mm
CRGPR3232P12V	32	32	40,0	171,3	—	—	8,0	RPGX120700E	NST3	CM216	CS412	3.5 mm
CRGPR2525M12V	25	25	32,0	151,3	27,1	6,4	7,0	RPGX120700E	NST3	CM216	CS412	3.5 mm
CRGPR3232P15V	32	32	40,0	171,3	37,1	6,4	8,0	RPGX151000	NST4	CM217	MS1294	6 mm
CRGPR4040R19V	40	40	50,0	201,5	—	—	10,0	RPGX191000	NST5	CM217	MS1294	6 mm
CRGPR3232P19V	32	32	40,0	171,3	41,0	6,4	8,0	RPGX191000	NST5	CM217	MS1294	6 mm
left hand												
CRGPL2525M06V	25	25	32,0	151,3	—	—	7,0	RPGX060400E	NST1	CM214	MS1321	2.5 mm
CRGPL3232P09V	32	32	40,0	171,3	—	—	8,0	RPGX090700E	NST2	CM219	CS412	3.5 mm
CRGPL2525M09V	25	25	32,0	151,3	—	—	7,0	RPGX090700E	NST2	CM219	CS412	3.5 mm
CRGPL3232P12V	32	32	40,0	171,3	—	—	8,0	RPGX120700E	NST3	CM216	CS412	3.5 mm
CRGPL2525M12V	25	25	32,0	151,3	27,1	6,4	7,0	RPGX120700E	NST3	CM216	CS412	3.5 mm
CRGPL3232P15V	32	32	40,0	171,3	37,1	6,4	8,0	RPGX151000	NST4	CM217	MS1294	6 mm
CRGPL4040R19V	40	40	50,0	201,5	—	—	10,0	RPGX191000	NST5	CM217	MS1294	6 mm
CRGPL3232P19V	32	32	40,0	171,3	41,0	6,4	8,0	RPGX191000	NST5	CM217	MS1294	6 mm

NOTE: CRGP Toolholders are able to use RPGX and RCGX insert styles.



Quick-Turn Solutions Program for CBN Inserts

Standard inserts incorporate latest grade, coating, edge preparation, and manufacturing technology. They cover a wide range of applications and provide superior performance.

However, in some cases, further fine tuning is needed to reach the optimum performance point. Therefore, Kennametal has set up the Quick-Turn Solutions Program (QTSP) to allow edge preparation modifications on selected styles, grades, and formats to further enhance the tool performance.

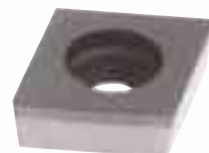

Technical Details • Options for a Customisation

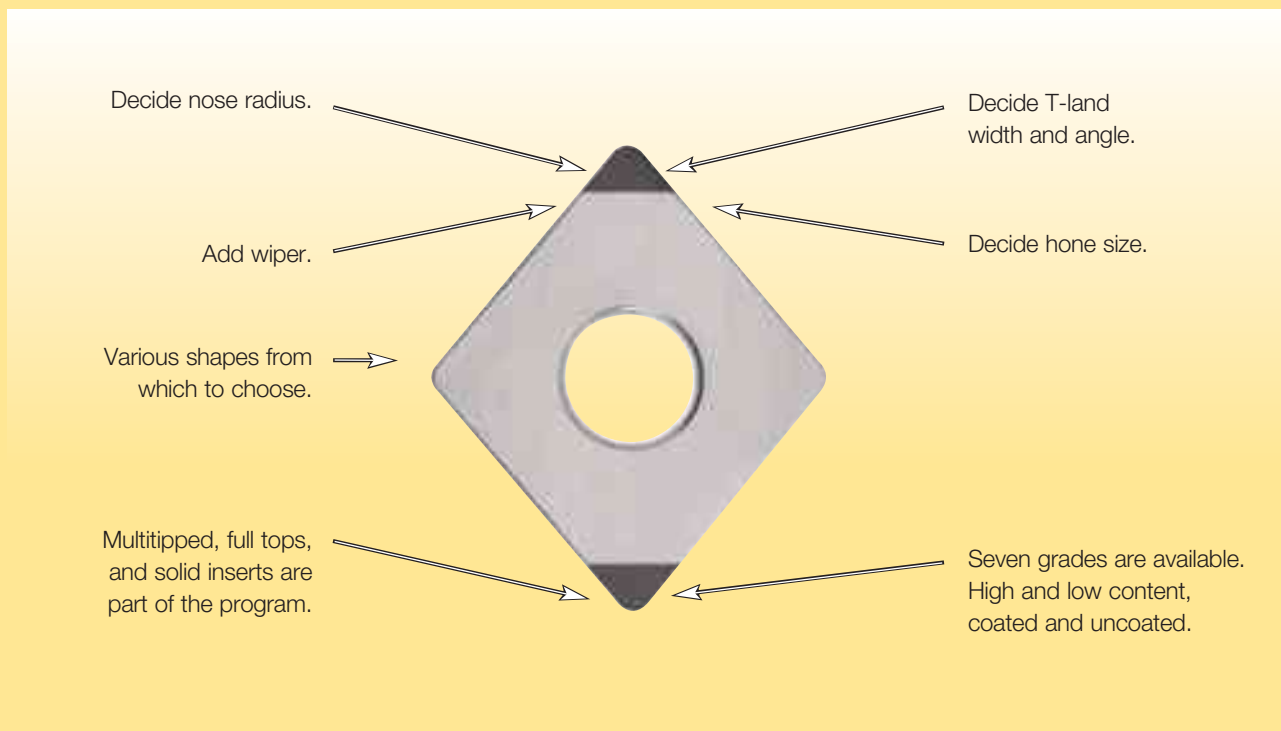

For more information, please contact a Kennametal Sales Representative, Authorised Kennametal Distributor, or visit www.kennametal.com.

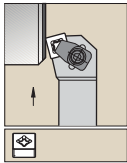

See pages B122 and B183 for inserts.

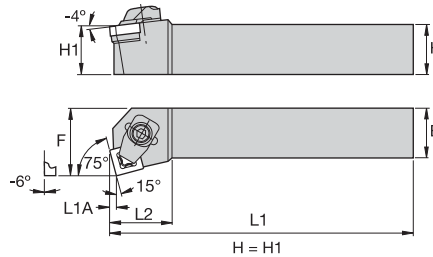

O.D./I.D. Tooling

■ CCKN 75° • MX



catalogue number	H	B	F	L1	L2	L1A	gage insert	shim	shim screw	hex (mm)	clamp assembly	hex (mm)
right hand												
CCKNR2525M12MX7	25	25	32,5	151	32,0	3,1	CNGX120708	552.221	554.252	2.5 mm	551.013	4 mm
CCKNR3225P12MX7	32	25	32,5	171	32,0	3,1	CNGX120708	552.221	554.252	2.5 mm	551.013	4 mm
left hand												
CCKNL2525M12MX7	25	25	32,5	151	32,0	3,1	CNGX120708	552.221	554.252	2.5 mm	551.013	4 mm

■ CCKN 75° • MN



catalogue number	H	B	F	L1	L2	L1A	gage insert	shim	shim screw	hex (mm)	clamp assembly	hex (mm)
right hand												
CCKNR3225P12MN7	32	25	32,5	171	32,0	3,1	CNGN120708	552.221	554.252	2.5 mm	551.255	4 mm
left hand												
CCKNL2525M12MN4	25	25	32,5	151	32,0	3,1	CNGN120408	552.220	554.252	2.5 mm	551.255	4 mm
CCKNL2525M12MN7	25	25	32,5	151	32,0	3,1	CNGN120708	552.221	554.252	2.5 mm	551.255	4 mm
CCKNL3225P12MN7	32	25	32,5	171	32,0	3,1	CNGN120708	552.221	554.252	2.5 mm	551.255	4 mm

■ CCKN 75° • MF



catalogue number	H	B	F	L1	L2	L1A	gage insert	shim	shim screw	hex (mm)	clamp assembly	hex (mm)
right hand												
CCKNR2525M12MF7	25	25	32,5	151	32,0	3,1	CNGN120708	552.221	554.252	2.5 mm	551.252	4 mm
left hand												
CCKNL2525M12MF4	25	25	32,5	151	32,0	3,1	CNGN120408	552.220	554.252	2.5 mm	551.252	4 mm
CCKNL2525M12MF7	25	25	32,5	151	32,0	3,1	CNGN120708	552.221	554.252	2.5 mm	551.255	4 mm

NOTE: MX — clamping version is shown.

Basic holder may be ordered separately:
V.SKN R/L 2525M12

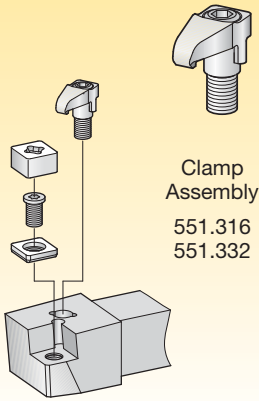
■ Spare Parts • -MX, -MN, -MF, and -MA Clamping Version
**Clamping Mode
MX**

Clamp
Assembly
551.316
551.332

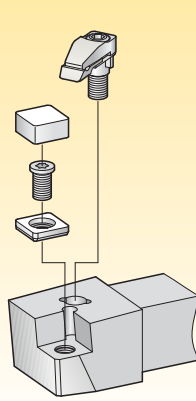
**Clamping Mode
MN**

Clamp
Assembly
551.251
551.255

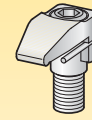
**Individual
Clamping Elements**

Clamping
Element
551.333
551.317

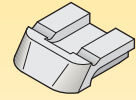

Pressure
Plate
557.111
557.111

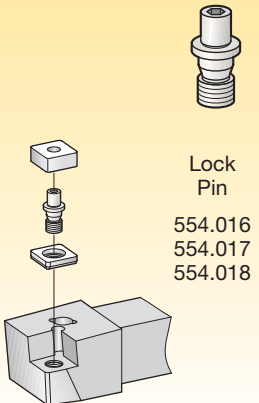
**Clamping Mode
MA**

Lock
Pin
554.016
554.017
554.018

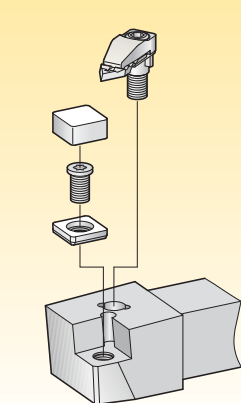
**Clamping Mode
MF**

Clamp
Assembly
551.252
551.253
551.254
551.256
551.257
551.258
551.260
551.261

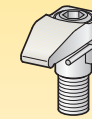
**Individual
Clamping Elements**

Clamping
Element
551.317
551.317
551.317
551.317
551.317
551.317
551.317
551.317
551.317

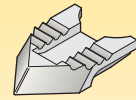

Chipbreaker
557.125
557.126
557.127
557.120
557.121
557.122
557.123
557.124

O.D./I.D. Tooling

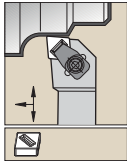

See pages B122 and B183 for inserts.

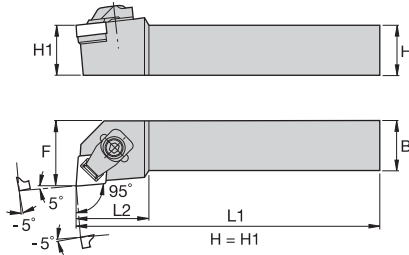

■ CCLN 95° • MX

O.D./I.D. Tooling



catalogue number	H	B	F	L1	L2	gage insert	shim	shim screw	hex	clamp assembly	hex
right hand											
CCLNR2525M12-MX7	25	25	32,0	150	32,0	CN.X120708	552.221	554.252	2.5 mm	551.316	4 mm
CCLNR3225P12-MX7	32	25	32,0	170	32,0	CN.X120708	552.221	554.252	2.5 mm	551.316	4 mm
left hand											
CCLNL2525M12-MX7	25	25	32,0	150	32,0	CN.X120708	552.221	554.252	2.5 mm	551.316	4 mm
CCLNL3225P12-MX7	32	25	32,0	170	32,0	CN.X120708	552.221	554.252	2.5 mm	551.316	4 mm

■ CCLN 95° • MN



catalogue number	H	B	F	L1	L2	gage insert	shim	shim screw	hex	thrust plate	clamp assembly	hex
right hand												
CCLNR2525M12-MN4	25	25	32,0	150	32,0	CN.N120408	552.220	554.252	2.5 mm	557.111	551.317	4 mm
CCLNR2525M12-MN7	25	25	32,0	150	32,0	CN.N120708	552.221	554.252	2.5 mm	557.111	551.317	4 mm
CCLNR3225P12-MN4	32	25	32,0	170	32,0	CN.N120408	552.220	554.252	2.5 mm	557.111	551.317	4 mm
CCLNR3225P12-MN7	32	25	32,0	170	32,0	CN.N120708	552.221	554.252	2.5 mm	557.111	551.317	4 mm
left hand												
CCLNL2525M12-MN4	25	25	32,0	150	32,0	CN.N120408	552.220	554.252	2.5 mm	557.111	551.317	4 mm
CCLNL2525M12-MN7	25	25	32,0	150	32,0	CN.N120708	552.221	554.252	2.5 mm	557.111	551.317	4 mm
CCLNL3225P12-MN7	32	25	32,0	170	32,0	CN.N120708	552.221	554.252	2.5 mm	557.111	551.317	4 mm

■ CCLN 95° • MF



catalogue number	H	B	F	L1	L2	gage insert	shim	shim screw	hex	chipbreaker	clamp assembly	hex
right hand												
CCLNR2525M12-MF4	25	25	32,0	150	32,0	CN.N120408	552.220	554.252	2.5 mm	557.125	551.317	4 mm
CCLNR2525M12-MF7	25	25	32,0	150	32,0	CN.N120708	552.221	554.252	2.5 mm	557.125	551.317	4 mm
left hand												
CCLNL2525M12-MF4	25	25	32,0	150	32,0	CN.N120408	552.220	554.252	2.5 mm	557.125	551.317	4 mm
CCLNL2525M12-MF7	25	25	32,0	150	32,0	CN.N120708	552.221	554.252	2.5 mm	557.125	551.317	4 mm

NOTE: MX — clamping version is shown.
 Basic holder may be ordered separately:
 V.CLN R/L 2525M12
 V.CLN R/L 3225P12
 V.CLN R/L 3225P16

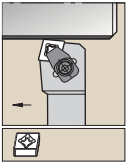

See pages B122 and B183 for inserts.

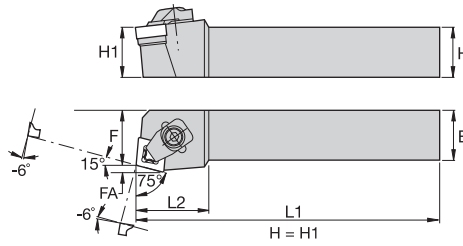
■ CCRN 75° • MX



catalogue number	H	B	F	L1	L2	FA	gage insert	shim	shim screw	hex	clamp assembly	hex
right hand												
CCRN3225P16-MX7	32	25	27,0	170	35,0	4,2	CN.X160708	552.223	554.253	3 mm	551.316	4 mm
left hand												
CCRN3225P16-MX7	32	25	27,0	170	35,0	4,2	CN.X160708	552.223	554.253	3 mm	551.316	4 mm

■ CCRN 75° • MN

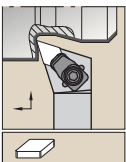
catalogue number	H	B	F	L1	L2	FA	gage insert	shim	shim screw	hex	thrust plate	clamp assembly	hex
right hand													
CCRN2525M12-MN7	25	25	27,0	150	35,0	3,1	CN.N120708	552.221	554.252	2.5 mm	557.111	551.317	4 mm
left hand													
CCRN3225P12-MN7	32	25	27,0	170	35,0	3,1	CN.N120708	552.221	554.252	2.5 mm	557.111	551.317	4 mm
CCRN2525M12-MN7	25	25	27,0	150	35,0	3,1	CN.N120708	552.221	554.252	2.5 mm	557.111	551.317	4 mm

 NOTE: MX — clamping version is shown.
 Basic holder may be ordered separately:
 V.CRN R/L 2525M12
 V.CRN R/L 3225P12
 V.CRN R/L 3225P16

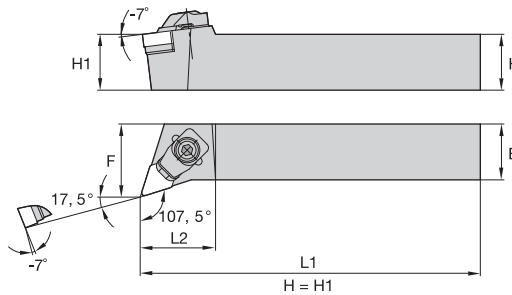
See pages B123 and B183 for inserts.



■ CDHN 107,5° • MX

catalogue number	H	B	F	L1	L2	gage insert	shim	shim screw	hex	clamp assembly	hex
right hand											
CDHNR2525M12-MX7	25	25	32,0	150	30,0	DN.X120708	552.225	554.254	2.5 mm	551.316	4 mm
left hand											
CDHNL3225P15-MX7	32	25	32,0	170	33,0	DN.X150708	552.228	554.252	2.5 mm	551.332	4 mm

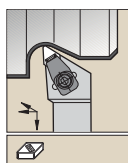
 NOTE: MN — clamping version is shown.
 Basic holder may be ordered separately:
 V.DHN R/L 2525M12
 V.DHN R/L 2525M15
 V.DHN R/L 3225P15

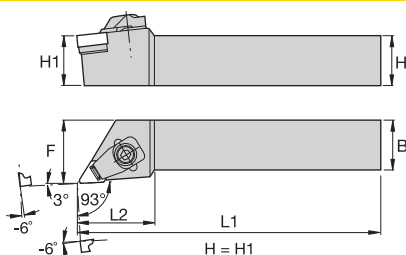

See pages B123 and B183 for inserts.



CDJN 93° • MX



catalogue number	H	B	F	L1	L2	gage insert	shim	shim screw	hex	clamp assembly	hex
right hand											
CDJNR2525M12-MX7	25	25	32,0	150	38,0	DN.X120708	552.225	554.254	2.5 mm	551.316	4 mm
CDJNR2525M15-MX7	25	25	32,0	150	38,0	DN.X150708	552.228	554.252	2.5 mm	551.332	4 mm
CDJNR3225P12MX7	32	25	32,5	171	38,0	DNGX120708	552.225	554.254	—	551.316	4 mm
left hand											
CDJNL2525M12-MX7	25	25	32,0	150	38,0	DN.X120708	552.225	554.254	2.5 mm	551.316	4 mm
CDJNL2525M15-MX7	25	25	32,0	150	38,0	DN.X150708	552.228	554.252	2.5 mm	551.332	4 mm
CDJNL3225P12MX7	32	25	32,5	171	38,0	DNGX120708	552.225	554.254	—	551.316	4 mm

CDJN 93° • MN



catalogue number	H	B	F	L1	L2	gage insert	shim	shim screw	hex	thrust plate	clamp assembly	hex
right hand												
CDJNR2525M15-MN7	25	25	32,0	150	38,0	DN.N150708	552.228	554.252	2.5 mm	557.111	551.317	4 mm
CDJNR3225P15-MN7	32	25	32,0	170	38,0	DN.N150708	552.228	554.252	2.5 mm	557.111	551.317	4 mm
left hand												
CDJNL2525M15-MN7	25	25	32,0	150	38,0	DN.N150708	552.228	554.252	2.5 mm	557.111	551.317	4 mm
CDJNL3225P15-MN7	32	25	32,0	170	38,0	DN.N150708	552.228	554.252	2.5 mm	557.111	551.317	4 mm

CDJN 93° • MF



catalogue number	H	B	F	L1	L2	gage insert	shim	shim screw	hex	chipbreaker	clamp assembly	hex
right hand												
CDJNR2525M15-MF7	25	25	32,0	150	38,0	DN.N150708	552.228	554.252	2.5 mm	557.123	551.317	4 mm
left hand												
CDJNL2525M15-MF7	25	25	32,0	150	38,0	DN.N150708	552.228	554.252	2.5 mm	557.124	551.317	4 mm

NOTE: MX — clamping version is shown.
 Basic holder may be ordered separately:
 V.DJN R/L 2525M12
 V.DJN R/L 3225M15
 V.DJN R/L 3225P15

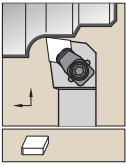

See pages B123–B124 for inserts.

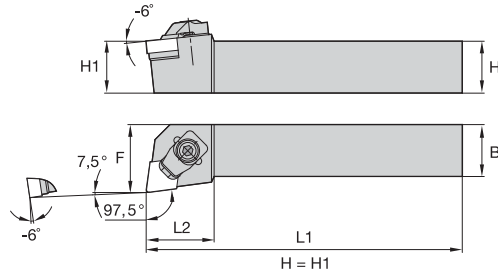

■ CELN 97,5° • MX



catalogue number	H	B	F	L1	L2	gage insert	shim	shim screw	hex	clamp assembly	hex
right hand											
CELNR2525M13-MX7	25	25	32,0	150	32,0	EN.X130708	552.240	554.252	2.5 mm	551.316	4 mm
left hand											
CELNL2525M13-MX7	25	25	32,0	150	32,0	EN.X130708	552.240	554.252	2.5 mm	551.316	4 mm

■ CELN 97,5° • MN



catalogue number	H	B	F	L1	L2	gage insert	shim	shim screw	hex	thrust plate	clamp assembly	hex
right hand												
CELNR2525M13-MN7	25	25	32,0	150	32,0	EN.N130708	552.240	554.252	2.5 mm	557.111	551.317	4 mm
left hand												
CELNL2525M13-MN7	25	25	32,0	150	32,0	EN.N130708	552.240	554.252	2.5 mm	557.111	551.317	4 mm

■ CELN 97,5° • MF



catalogue number	H	B	F	L1	L2	gage insert	shim	shim screw	hex	chipbreaker	clamp assembly	hex
right hand												
CELNR2525M13-MF7	25	25	32,0	150	32,0	EN.N130708	552.240	554.252	2.5 mm	557.125	551.317	4 mm
left hand												
CELNL2525M13-MF7	25	25	32,0	150	32,0	EN.N130708	552.240	554.252	2.5 mm	557.125	551.317	4 mm

NOTE: MN — clamping version is shown.
Basic holder may be ordered separately:
V.ELN R/L 2525M13
V.ELN R/L 3225P13

O.D./I.D. Tooling

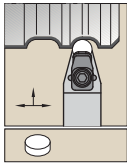

See page B124 for inserts.

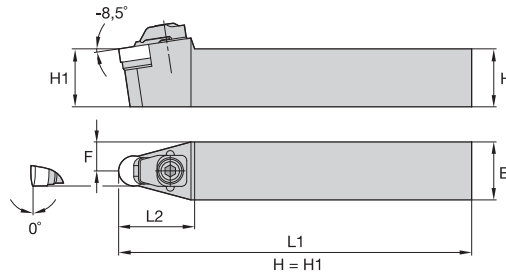

■ CRDN • MN



O.D./I.D. Tooling

catalogue number	H	B	F	L1	L2	gage insert	shim	shim screw	hex	thrust plate	clamp assembly	hex
CRDNN2525M12-MN4	25	25	12,5	150	30,0	RN.N120400	552.229	554.252	2.5 mm	557.111	551.333	4 mm
CRDNN2525M12-MN7	25	25	12,5	150	30,0	RN.N120700	552.230	554.252	2.5 mm	557.111	551.333	4 mm
CRDNN3225P12-MN4	32	25	12,5	170	30,0	RN.N120400	552.229	554.252	2.5 mm	557.111	551.333	4 mm
CRDNN3225P12-MN7	32	25	12,5	170	30,0	RN.N120700	552.230	554.252	2.5 mm	557.111	551.333	4 mm

NOTE: MN — clamping version is shown.
Basic holder may be ordered separately:
V.RDN N 2525M12
V.RDN N 3225M12

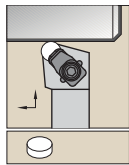

See page B124 for inserts.

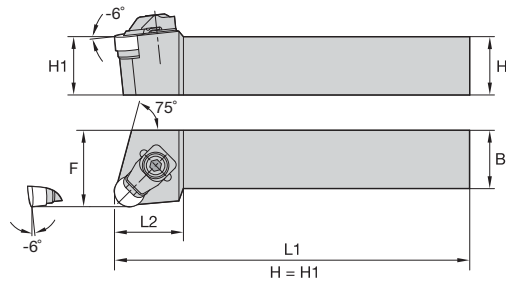

■ CRSN • MN



catalogue number	H	B	F	L1	L2	gage insert	shim	shim screw	hex	thrust plate	clamp assembly	hex
right hand												
CRSNR2525M12-MN4	25	25	32,0	150	26,0	RN.N120400	552.229	554.252	2.5 mm	557.111	551.333	4 mm
CRSNR2525M12-MN7	25	25	32,0	150	26,0	RN.N120700	552.230	554.252	2.5 mm	557.111	551.333	4 mm
CRSNR3225P12-MN4	32	25	32,0	170	26,0	RN.N120400	552.229	554.252	2.5 mm	557.111	551.333	4 mm
CRSNR3225P12-MN7	32	25	32,0	170	26,0	RN.N120700	552.230	554.252	2.5 mm	557.111	551.333	4 mm
left hand												
CRSNL2525M12-MN4	25	25	32,0	150	26,0	RN.N120400	552.229	554.252	2.5 mm	557.111	551.333	4 mm
CRSNL2525M12-MN7	25	25	32,0	150	26,0	RN.N120700	552.230	554.252	2.5 mm	557.111	551.333	4 mm
CRSNL3225P12-MN4	32	25	32,0	170	26,0	RN.N120400	552.229	554.252	2.5 mm	557.111	551.333	4 mm
CRSNL3225P12-MN7	32	25	32,0	170	26,0	RN.N120700	552.230	554.252	2.5 mm	557.111	551.333	4 mm

NOTE: MN — clamping version is shown.
Basic holder may be ordered separately:
V.RSN R/L 2525M12
V.RSN R/L 3225P12

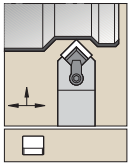

See pages B125–B126 and B184 for inserts.

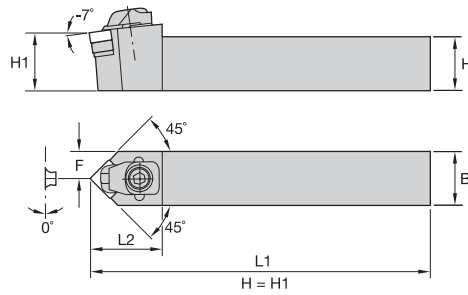
■ CSDN • MX

catalogue number	H	B	F	L1	L2	gage insert	shim	shim screw	hex	clamp assembly	hex
CSDNN2525M12MX7	25	25	12,5	151	36,0	SNGX120708	552.232	554.252	2.5 mm	551.316	4 mm
CSDNN3225P12MX7	32	25	12,5	171	36,0	SNGX120708	552.232	554.252	2.5 mm	551.316	4 mm

■ CSDN • MN



catalogue number	H	B	F	L1	L2	gage insert	shim	shim screw	hex	clamp assembly	hex
CSDNN2525M12MN4	25	25	12,5	151	36,0	SNGN120408	552.231	554.252	2.5 mm	551.255	4 mm
CSDNN2525M12MN7	25	25	12,5	151	36,0	SNGN120708	552.232	554.252	2.5 mm	551.255	4 mm
CSDNN3225P12MN4	32	25	12,5	171	36,0	SNGN120408	552.231	554.252	2.5 mm	551.255	4 mm
CSDNN3225P12MN7	32	25	12,5	171	36,0	SNGN120708	552.232	554.252	2.5 mm	551.255	4 mm

■ CSDN • MF

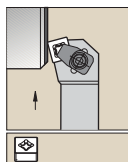

catalogue number	H	B	F	L1	L2	gage insert	shim	shim screw	hex	clamp assembly	hex
CSDNN2525M12MF4	25	25	12,5	151	36,0	SNGN120408	552.231	554.252	2.5 mm	551.252	4 mm
CSDNN2525M12MF7	25	25	12,5	151	36,0	SNGN120708	552.232	554.252	2.5 mm	551.252	4 mm
CSDNN3225P12MF4	32	25	12,5	171	36,0	SNGN120408	552.231	554.252	2.5 mm	551.252	4 mm
CSDNN3225P12MF7	32	25	12,5	171	36,0	SNGN120708	552.232	554.252	2.5 mm	551.252	4 mm

NOTE: MN — clamping version is shown.
 Basic holder may be ordered separately:
 V.SRN R/L 2525M12
 V.SRN R/L 3225P12
 V.SRN R/L 3225P15

O.D./I.D. Tooling

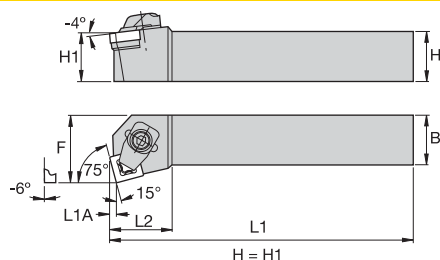

See pages B125–B126 and B184 for inserts.



CSKN 75° • MN



catalogue number	H	B	F	L1	L2	L1A	gage insert	shim	shim screw	hex	thrust plate	clamp assembly	hex
right hand													
CSKNR2525M12-MN4	25	25	32,0	150	27,0	3,0	SN.N120408	552.231	554.252	2.5 mm	557.111	551.317	4 mm
CSKNR2525M12-MN7	25	25	32,0	150	27,0	3,0	SN.N120708	552.232	554.252	2.5 mm	557.111	551.317	4 mm
left hand													
CSKNL2525M12-MN4	25	25	32,0	150	27,0	3,0	SN.N120408	552.231	554.252	2.5 mm	557.111	551.317	4 mm
CSKNL2525M12-MN7	25	25	32,0	150	27,0	3,0	SN.N120708	552.232	554.252	2.5 mm	557.111	551.317	4 mm

NOTE: MX — clamping version is shown.
Basic holder may be ordered separately:
V.SKN R/L 2525M12

O.D./I.D. Tooling

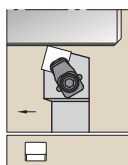

See pages B125–B126 and B184 for inserts.

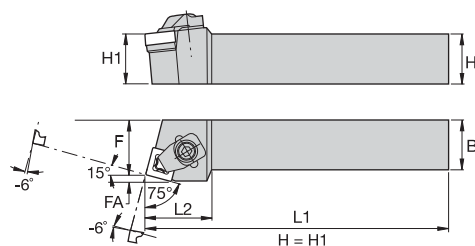

CSRN 75° • MX

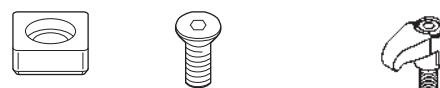

catalogue number	H	B	F	L1	L2	FA	gage insert	shim	shim screw	hex	clamp assembly	hex
left hand												
CSRNL3225P15-MX7	32	25	27,0	170	34,0	4,1	SN.X150708	552.234	554.253	3 mm	551.316	4 mm

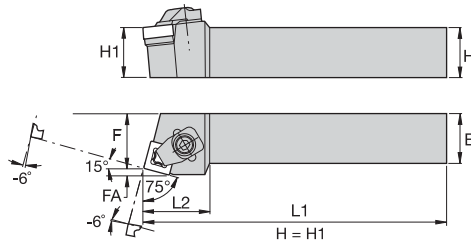
■ CSRN 75° • MN



catalogue number	H	B	F	L1	L2	FA	gage insert	shim	shim screw	hex	thrust plate	clamp assembly	hex
right hand													
CSRRN2525M12-MN4	25	25	27,0	150	32,0	3,1	SN.N120408	552.231	554.252	2.5 mm	557.111	551.317	4 mm
CSRRN2525M12-MN7	25	25	27,0	150	32,0	3,1	SN.N120708	552.232	554.252	2.5 mm	557.111	551.317	4 mm
CSRRN3225P12-MN4	32	25	27,0	170	32,0	3,1	SN.N120408	552.231	554.252	2.5 mm	557.111	551.317	4 mm
CSRRN3225P12-MN7	32	25	27,0	170	32,0	3,1	SN.N120708	552.232	554.252	2.5 mm	557.111	551.317	4 mm
left hand													
CSRNL2525M12-MN4	25	25	27,0	150	32,0	3,1	SN.N120408	552.231	554.252	2.5 mm	557.111	551.317	4 mm
CSRNL2525M12-MN7	25	25	27,0	150	32,0	3,1	SN.N120708	552.232	554.252	2.5 mm	557.111	551.317	4 mm
CSRNL3225P12-MN4	32	25	27,0	170	32,0	3,1	SN.N120408	552.231	554.252	2.5 mm	557.111	551.317	4 mm
CSRNL3225P12-MN7	32	25	27,0	170	32,0	3,1	SN.N120708	552.232	554.252	2.5 mm	557.111	551.317	4 mm

■ CSRN 75° • MF

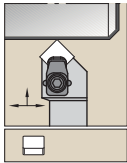

catalogue number	H	B	F	L1	L2	FA	gage insert	shim	shim screw	hex	chipbreaker	clamp assembly	hex
right hand													
CSRRN2525M12-MF4	25	25	27,0	150	32,0	3,1	SN.N120408	552.231	554.252	2.5 mm	557.126	551.317	4 mm
CSRRN2525M12-MF7	25	25	27,0	150	32,0	3,1	SN.N120708	552.232	554.252	2.5 mm	557.126	551.317	4 mm
CSRRN3225P15-MF7	32	25	27,0	170	34,0	4,1	SN.N150708	552.234	554.253	3 mm	557.121	551.317	4 mm
left hand													
CSRNL2525M12-MF4	25	25	27,0	150	32,0	3,1	SN.N120408	552.231	554.252	2.5 mm	557.127	551.317	4 mm
CSRNL2525M12-MF7	25	25	27,0	150	32,0	3,1	SN.N120708	552.232	554.252	2.5 mm	557.127	551.317	4 mm
CSRNL3225P15-MF7	32	25	27,0	170	34,0	4,1	SN.N150708	552.234	554.253	3 mm	557.122	551.317	4 mm

NOTE: MX — clamping version is shown.
 Basic holder may be ordered separately:
 V.SRN R/L 2525M12
 V.SRN R/L 3225P12
 V.SRN R/L 3225P15

O.D./I.D. Tooling

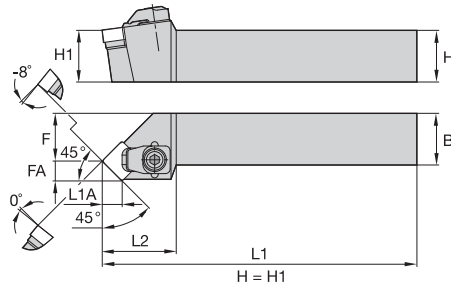

See pages B125–B126 and B184 for inserts.



■ CSSN 45° • MX



O.D./I.D. Tooling

catalogue number	H	B	F	L1	L2	FA	L1A	gage insert	shim	shim screw	hex	clamp assembly	hex
right hand													
CSSNR2525M12-MX7	25	25	32,0	150	35,0	8,3	8,3	SN.X120708	552.232	554.252	2.5 mm	551.316	4 mm
CSSNR3225P15-MX7	32	25	32,0	159	37,0	10,6	10,6	SN.X150708	552.234	554.253	3 mm	551.316	4 mm
left hand													
CSSNL2525M12-MX7	25	25	32,0	150	35,0	8,3	8,3	SN.X120708	552.232	554.252	2.5 mm	551.316	4 mm

■ CSSN 45° • MN



catalogue number	H	B	F	L1	L2	FA	L1A	gage insert	shim	shim screw	hex	thrust plate	clamp assembly	hex
right hand														
CSSNR2525M12-MN7	25	25	32,0	142	35,0	8,3	8,3	SN.N120708	552.232	554.252	2.5 mm	557.111	551.317	4 mm
CSSNR3225P12-MN4	32	25	32,0	162	35,0	8,3	8,3	SN.N120408	552.231	554.252	2.5 mm	557.111	551.317	4 mm
CSSNR3225P12-MN7	32	25	32,0	162	35,0	8,3	8,3	SN.N120708	552.232	554.252	2.5 mm	557.111	551.317	4 mm
left hand														
CSSNL2525M12-MN7	25	25	32,0	142	35,0	8,3	8,3	SN.N120708	552.232	554.252	2.5 mm	557.111	551.317	4 mm
CSSNL3225P12-MN4	32	25	32,0	162	35,0	8,3	8,3	SN.N120408	552.231	554.252	2.5 mm	557.111	551.317	4 mm
CSSNL3225P12-MN7	32	25	32,0	162	35,0	8,3	8,3	SN.N120708	552.232	554.252	2.5 mm	557.111	551.317	4 mm

■ CSSN 45° • MF



catalogue number	H	B	F	L1	L2	FA	L1A	gage insert	shim	shim screw	hex	chipbreaker	clamp assembly	hex
right hand														
CSSNR2525M12-MF7	25	25	32,0	142	35,0	8,3	8,3	SN.N120708	552.232	554.252	2.5 mm	557.125	551.317	4 mm
left hand														
CSSNL2525M12-MF7	25	25	32,0	142	35,0	8,3	8,3	SN.N120708	552.232	554.252	2.5 mm	557.125	551.317	4 mm

NOTE: MN — clamping version is shown.
 Basic holder may be ordered separately:
 V.SSN R/L 2525M12
 V.SSN R/L 3225P12
 V.SSN R/L 3225P15

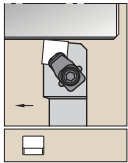

See pages B125–B126 and B184 for inserts.

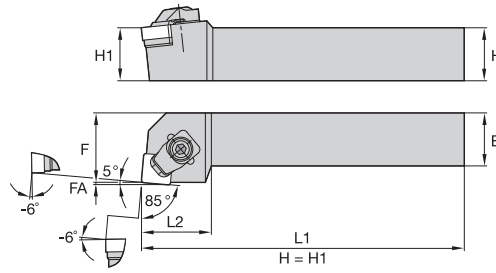
■ CSXN 85° • MX

catalogue number	H	B	F	L1	L2	FA	gage insert	shim	shim screw	hex	clamp assembly	hex
right hand												
CSXNR2525M12-MX7	25	25	32,0	150	30,0	1,1	SN.X120708	552.232	554.252	2.5 mm	551.316	4 mm
left hand												
CSXNR3225P12-MX7	32	25	32,0	170	30,0	1,1	SN.X120708	552.232	554.252	2.5 mm	551.316	4 mm
right hand												
CSXNL2525M12-MX7	25	25	32,0	150	30,0	1,1	SN.X120708	552.232	554.252	2.5 mm	551.316	4 mm
left hand												
CSXNL3225P12-MX7	32	25	32,0	170	30,0	1,1	SN.X120708	552.232	554.252	2.5 mm	551.316	4 mm

■ CSXN 85° • MN

catalogue number	H	B	F	L1	L2	FA	gage insert	shim	shim screw	hex	thrust plate	clamp assembly	hex
right hand													
CSXNR2525M12-MN4	25	25	32,0	150	30,0	1,1	SN.N120408	552.231	554.252	2.5 mm	557.111	551.317	4 mm
left hand													
CSXNL2525M12-MN4	25	25	32,0	150	30,0	1,1	SN.N120408	552.231	554.252	2.5 mm	557.111	551.317	4 mm

■ CSXN 85° • MF

catalogue number	H	B	F	L1	L2	FA	gage insert	shim	shim screw	hex	chipbreaker	clamp assembly	hex
right hand													
CSXNR2525M12-MF7	25	25	32,0	150	30,0	1,1	SN.N120708	552.232	554.252	2.5 mm	557.126	551.317	4 mm
left hand													
CSXNL2525M12-MF7	25	25	32,0	150	30,0	1,1	SN.N120708	552.232	554.252	2.5 mm	557.127	551.317	4 mm

NOTE: MN — clamping version is shown.
 Basic holder may be ordered separately:
 V.SXN R/L 2525M12
 V.SXN R/L 3225P12

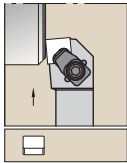

See pages B125–B126 and B184 for inserts.

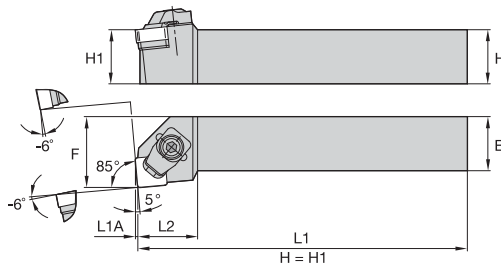

CSYN 85° • MX



catalogue number	H	B	F	L1	L2	L1A	gage insert	shim	shim screw	hex	clamp assembly	hex
left hand												
CSYNL3225P12-MX7	32	25	32,0	170	27,0	1,0	SN.X120708	552.232	554.252	2.5 mm	551.316	4 mm

O.D./I.D. Tooling

CSYN 85° • MN



catalogue number	H	B	F	L1	L2	L1A	gage insert	shim	shim screw	hex	thrust plate	clamp assembly	hex
right hand													
CSYNR2525M12-MN4	25	25	32,0	150	27,0	1,1	SN.N120408	552.231	554.252	2.5 mm	557.111	551.317	4 mm
CSYNR2525M12-MN7	25	25	32,0	150	27,0	1,1	SN.N120708	552.232	554.252	2.5 mm	557.111	551.317	4 mm
left hand													
CSYNL2525M12-MN4	25	25	32,0	150	27,0	1,1	SN.N120408	552.231	554.252	2.5 mm	557.111	551.317	4 mm
CSYNL2525M12-MN7	25	25	32,0	150	27,0	1,1	SN.N120708	552.232	554.252	2.5 mm	557.111	551.317	4 mm

NOTE: MN — clamping version is shown.
Basic holder may be ordered separately:
V.SYN R/L 2525M12
V.SYN R/L 3225P12

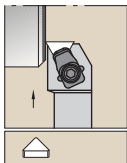

See pages B126 and B184 for inserts.

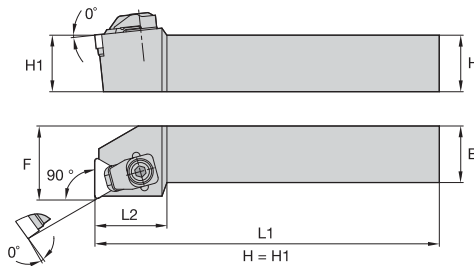

CTFN 90° • MN



catalogue number	H	B	F	L1	L2	gage insert	shim	shim screw	hex	thrust plate	clamp assembly	hex
right hand												
CTFNR2525M16-MN4	25	25	32,0	150	29,0	TN.N160408	552.235-H	554.254	2.5 mm	557.111	551.333	4 mm
left hand												
CTFNL2525M16-MN4	25	25	32,0	150	29,0	TN.N160408	552.235-H	554.254	2.5 mm	557.111	551.333	4 mm

NOTE: MN — clamping version is shown.
Basic holder may be ordered separately:
V.TFN R/L 2525M16

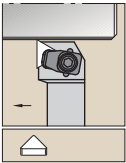

See pages B126 and B184 for inserts.

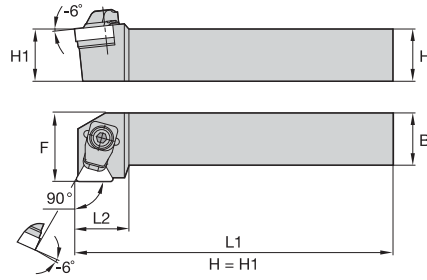
CTGN 90° • MN

catalogue number	H	B	F	L1	L2	gage insert	shim	shim screw	hex	thrust plate	clamp assembly	hex
right hand												
CTGNR2525M16-MN4	25	25	32,0	150	20,0	TN.N160408	552.235-H	554.254	2.5 mm	557.111	551.333	4 mm
left hand												
CTGNR2525M16-MN7	25	25	32,0	150	20,0	TN.N160708	552.236	554.254	2.5 mm	557.111	551.333	4 mm
right hand												
CTGNL2525M16-MN4	25	25	32,0	150	20,0	TN.N160408	552.235-H	554.254	2.5 mm	557.111	551.333	4 mm
CTGNL2525M16-MN7	25	25	32,0	150	20,0	TN.N160708	552.236	554.254	2.5 mm	557.111	551.333	4 mm

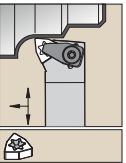
 NOTE: MN — clamping version is shown.
 Basic holder may be ordered separately:
 V.TGN R/L 2525M16

See page B127 for inserts.

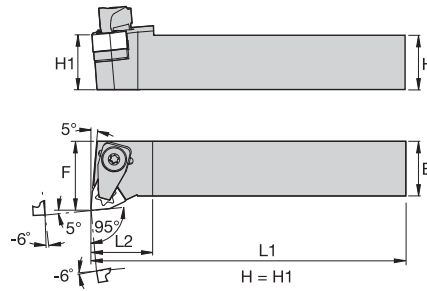
CWLN 95° • MX

catalogue number	H	B	F	L1	L2	gage insert	shim	shim screw	hex	clamp assembly	hex
right hand											
CWLN2525M08MX7	25	25	32,0	150	32,0	WN.X080708	552.210	554.252	2.5 mm	551.316	4 mm
left hand											
CWLN2525M08MX7	32	25	32,0	170	32,0	WN.X080708	552.210	554.252	2.5 mm	551.316	4 mm
right hand											
CWLN2525M08MX7	25	25	32,0	150	32,0	WN.X080708	552.210	554.252	2.5 mm	551.316	4 mm

O.D./I.D. Tooling

tool path	insert shape	clamping style	boring	back boring	profiling	page(s)
117,5° Lead Angle						
		Kenclamp™	•	•		C78
107,5° Lead Angle						
		Kenclamp	•	•	•	C79
		Screw-On	•	•		C94-C95
		Screw-On	•	•	•	C102
95° Lead Angle						
		Kenloc™	•	•		C82
		Kenclamp	•	•		C78
Screw-On		•	•		C90-C94	
Kenlever™		•	•		C105	
		MTS	•	•		C107
		MTS	•	•		-
		Screw-On	•	•		C100-C101
		Kenloc	•			C84
		Kenclamp	•	•		C81
		Kenlever	•	•		C106
		Screw-On	•	•		C103
		MTS	•	•		C109
93° Lead Angle						
		Kenloc	•	•	•	C82
		Kenclamp	•	•	•	C79
		Screw-On	•	•		C95-C97
			MTS	•	•	
		Kenloc	•	•		C84
		Kenclamp	•	•		C81
		Screw-On	•	•	•	C103
		Kendex™	•	•		C86
		Screw-On	•	•		C104

tool path	insert shape	clamping style	boring	back boring	profiling	page(s)
90° Lead Angle						
		Screw-On	•	•		C87-C89
		Kenloc	•			C83
		Kenclamp	•	•		C80
		Kenlever	•	•		C106
		Kendex	•	•		C85
		Screw-On	•			C98-C100
75° Lead Angle						
		Screw-On	•			C89
		Kenloc	•			C83
		Kenclamp	•			C80
		Kenlever	•			C105
		Kendex	•			C85
		Screw-On	•			C97-C98
		MTS	•			-
		Kendex	•			-
60° Lead Angle						
		Screw-On	•	•		C102
45° Lead Angle						
		MTS	•			C108

Clamping Styles

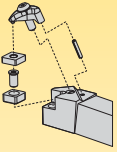

Kenclamp™ Style

- Suitable for Kenloc inserts.
- Unique clamp design provides rigid clamping.
- Ensures insert repeatability and seating.
- Reduced chatter and improved tool life.

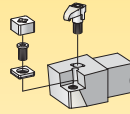

MTS Style

- Proven superior system in holding ceramic inserts rigidly in turning and profiling operations.
- Uses standard insert sizes — 80°, 75°, 55°, square, and trigon.
- This system offers the added versatility of using optional hardware to hold standard Kendex and Kenloc inserts.

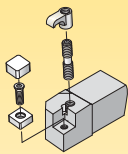

Kendex™ Style

- Suitable for Kendex inserts.
- Chipbreaker option available for ceramic inserts.
- Wide variety of insert styles may be used.

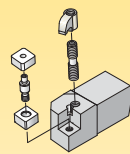

Kenloc™ Style

- Suitable for Kenloc inserts.
- Lock pin and top clamp provide rigid clamping.
- Wide variety of insert styles may be used.
- Tools may be used with or without clamp.

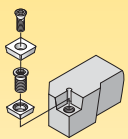

Screw-On Style

- Top clamping by screw for Screw-On inserts.

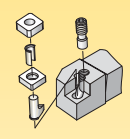

Kenlever™ Style

- Proven superior system for holding ceramic inserts rigidly in turning and profiling operations.
- Can be used on Kendex or Kenloc inserts using optional hardware.

How Do Catalogue Numbers Work?

Each character in our catalogue number signifies a specific trait of that product. Use the following key columns and corresponding images to easily identify which attributes apply.



A32SMSKNR12











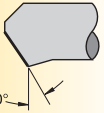
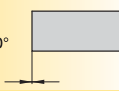
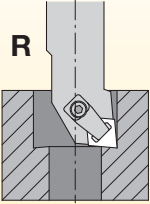

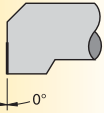
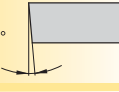
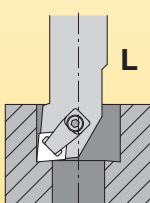

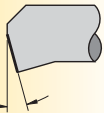
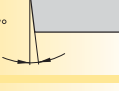

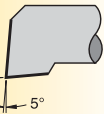
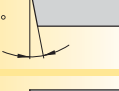

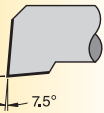
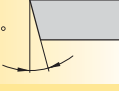

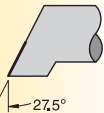
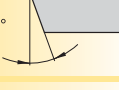
O.D./I.D. Tooling

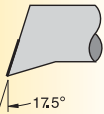
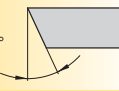
A	32	S	M	S																																																
Bar Type	Bar Diameter	Bar Length	Insert Holding Method	Insert Shape																																																
<p>A</p> <p>Steel bar with coolant</p>	<p>Metric: A two-digit number indicates the bar diameter in mm. If the diameter is represented by a one digit number, a 0 (zero) will be used in front of it. Example: 8mm = 08</p>	<table border="0"> <thead> <tr> <th>L1</th> <th>ISO</th> </tr> </thead> <tbody> <tr><td>32</td><td>= A</td></tr> <tr><td>40</td><td>= B</td></tr> <tr><td>50</td><td>= C</td></tr> <tr><td>60</td><td>= D</td></tr> <tr><td>70</td><td>= E</td></tr> <tr><td>80</td><td>= F</td></tr> <tr><td>90</td><td>= G</td></tr> <tr><td>100</td><td>= H</td></tr> <tr><td>110</td><td>= J</td></tr> <tr><td>125</td><td>= K</td></tr> <tr><td>140</td><td>= L</td></tr> <tr><td>150</td><td>= M</td></tr> <tr><td>160</td><td>= N</td></tr> <tr><td>170</td><td>= P</td></tr> <tr><td>180</td><td>= Q</td></tr> <tr><td>200</td><td>= R</td></tr> <tr><td>250</td><td>= S</td></tr> <tr><td>300</td><td>= T</td></tr> <tr><td>350</td><td>= U</td></tr> <tr><td>400</td><td>= V</td></tr> <tr><td>450</td><td>= W</td></tr> <tr><td>500</td><td>= Y</td></tr> <tr><td>Special Length</td><td>= X</td></tr> </tbody> </table>	L1	ISO	32	= A	40	= B	50	= C	60	= D	70	= E	80	= F	90	= G	100	= H	110	= J	125	= K	140	= L	150	= M	160	= N	170	= P	180	= Q	200	= R	250	= S	300	= T	350	= U	400	= V	450	= W	500	= Y	Special Length	= X	<p>C</p> <p>Kendex™</p> <p>N</p> <p>Top Notch™ Profiling</p> <p>D</p> <p>Kenclamp™</p> <p>M</p> <p>Kenloc™</p> <p>S</p> <p>Screw-On</p> <p>P</p> <p>Kenlever™</p>	<p>A</p> <p>B</p> <p>C</p> <p>D</p> <p>E</p> <p>H</p> <p>K</p> <p>L</p> <p>M</p> <p>O</p> <p>P</p> <p>R</p> <p>S</p> <p>T</p> <p>V</p> <p>W</p>
L1			ISO																																																	
32			= A																																																	
40			= B																																																	
50			= C																																																	
60			= D																																																	
70			= E																																																	
80			= F																																																	
90			= G																																																	
100			= H																																																	
110	= J																																																			
125	= K																																																			
140	= L																																																			
150	= M																																																			
160	= N																																																			
170	= P																																																			
180	= Q																																																			
200	= R																																																			
250	= S																																																			
300	= T																																																			
350	= U																																																			
400	= V																																																			
450	= W																																																			
500	= Y																																																			
Special Length	= X																																																			
<p>S</p> <p>Steel bar without coolant</p>																																																				
<p>C</p> <p>Carbide bar</p>																																																				
<p>D</p> <p>DeVibrator bar with coolant</p>																																																				
<p>D</p> <p>Tuneable bar with coolant</p>																																																				
<p>E</p> <p>Carbide bar with coolant</p>																																																				
<p>B</p> <p>DeVibrator</p>																																																				
<p>H</p> <p>Interchangeable head</p>																																																				
<p>L</p> <p>Heavy metal bar with coolant</p>																																																				

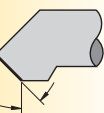
By referencing this easy-to-use guide, you can identify the correct product to meet your needs.

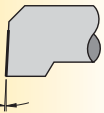

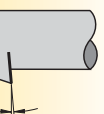
A32SMSKNR12

K	N	R	12	
Bar Style or Lead Angle	Insert Clearance Angle	Hand of Tool	Insert Size	Additional Information
E 	N 0° 	R = Right-hand boring bar 	Cutting Edge Length L10 H 	M. = TNT/MTS clamping systems for ceramic and PCBN inserts
F 	B 5° 	L = Left-hand boring bar 	O 	D = Dual pocket
K 	C 7° 		P 	AP5 = Axial positive
L 	P 11° 		S 	KC = Kenclamp™
(E-style inserts) L 	D 15° 		T 	+ = Insert thickness
P 	E 20° 		CDE M V 	
Q 	F 25° 		W 	
S 			L 	
U 			A B K 	
X 			H 	

O.D./I.D. Tooling

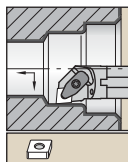

Steel shank with through coolant.

See pages B40–B49 and B174–B176 for inserts.

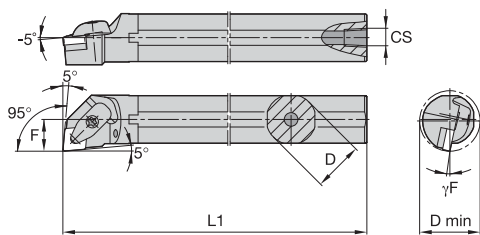

A-DCLN-KC 95°



O.D./I.D. Tooling

catalogue number	D	D min	F	L1	CS	γF°	gage insert	shim	shim screw	Torx Plus	clamp assembly	slotted pin	Torx Plus
right hand													
A25RDCLNR12KC04	25	32,0	17,0	200	1/4-18 NPT	-12.0	CN..120408	—	—	—	CM234R ASSY	SSP025016M	15 IP
A32SDCLNR12KC04	32	40,0	22,0	250	1/4-18 NPT	-12.0	CN..120408	ICSN433	KMSP415IP	15 IP	CM234R ASSY	SSP025016M	15 IP
A40TDCLNR12KC04	40	50,0	27,0	300	1/4-18 NPT	-9.0	CN..120408	ICSN433	KMSP415IP	15 IP	CM234R ASSY	SSP025016M	15 IP
A40TDCLNR16KC06	40	50,0	27,0	300	1/4-18 NPT	-12.0	CN..160612	ICSN533	KMSP515IP	15 IP	CM209R ASSY	SSP025018M	15 IP
left hand													
A25RDCLNL12KC04	25	32,0	17,0	200	1/4-18 NPT	-12.0	CN..120408	—	—	—	CM234R ASSY	SSP025016M	15 IP
A32SDCLNL12KC04	32	40,0	22,0	250	1/4-18 NPT	-12.0	CN..120408	ICSN433	KMSP415IP	15 IP	CM234R ASSY	SSP025016M	15 IP
A40TDCLNL12KC04	40	50,0	27,0	300	1/4-18 NPT	-9.0	CN..120408	ICSN433	KMSP415IP	15 IP	CM234R ASSY	SSP025016M	15 IP
A40TDCLNL16KC06	40	50,0	27,0	300	1/4-18 NPT	-12.0	CN..160612	ICSN533	KMSP515IP	15 IP	CM209R ASSY	SSP025018M	15 IP

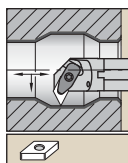

Steel shank with through coolant.

See pages B50–B58 and B176–B178 for inserts.

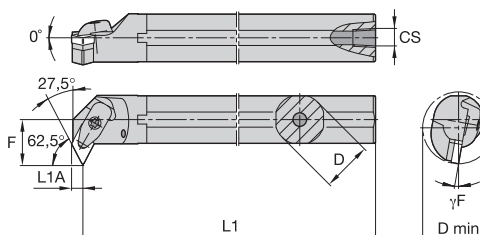

A-DDPN-KC 117,5°



catalogue number	D	D min	F	L1	L1A	CS	γF°	gage insert	shim	shim screw	Torx Plus	clamp assembly	slotted pin	Torx Plus
right hand														
A25RDDPNR11KC04	25	37,0	22,0	200	4,8	1/4-18 NPT	-10.0	DN..110408	IDSN322	KMSP315IP	9 IP	CM234R ASSY	SSP025016M	15 IP
A32SDDPNR15KC06	32	45,0	27,0	250	6,5	1/4-18 NPT	-12.0	DN..150608	IDSN433	KMSP415IP	15 IP	CM234R ASSY	SSP025016M	15 IP
A40TDDPNR15KC06	40	52,0	30,0	300	6,6	1/4-18 NPT	-10.0	DN..150608	IDSN433	KMSP415IP	15 IP	CM234R ASSY	SSP025016M	15 IP
left hand														
A25RDDPNL11KC04	25	37,0	22,0	200	4,8	1/4-18 NPT	-10.0	DN..110408	IDSN322	KMSP315IP	9 IP	CM234R ASSY	SSP025016M	15 IP
A32SDDPNL15KC06	32	45,0	27,0	250	6,5	1/4-18 NPT	-12.0	DN..150608	IDSN433	KMSP415IP	15 IP	CM234R ASSY	SSP025016M	15 IP
A40TDDPNL15KC06	40	52,0	30,0	300	6,6	1/4-18 NPT	-10.0	DN..150608	IDSN433	KMSP415IP	15 IP	CM234R ASSY	SSP025016M	15 IP

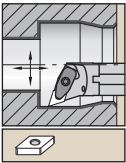

Steel shank with through coolant.

See pages B50–B58 and B176–B178 for inserts.

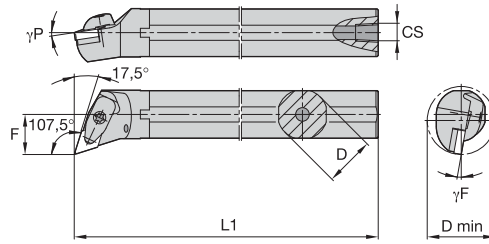

■ **A-DDQN-KC 107,5°**

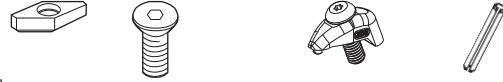

catalogue number	D	D min	F	L1	CS	γF°	γP°	gage insert	shim	shim screw	Torx Plus	clamp assembly	slotted pin	Torx Plus
right hand														
A25RDDQNR11KC04	25	32,0	17,0	200	1/4-18 NPT	-11,0	-7,0	DN..110408	—	—	—	CM234R ASSY	SSP025016M	15 IP
A32SDDQNR15KC06	32	40,0	22,0	250	1/4-18 NPT	-12,0	-10,0	DN..150608	IDSN433	KMSP415IP	15 IP	CM234R ASSY	SSP025016M	15 IP
A40TDDQNR15KC06	40	50,0	27,0	300	1/4-18 NPT	-10,0	-10,0	DN..150608	IDSN433	KMSP415IP	15 IP	CM234R ASSY	SSP025016M	15 IP
left hand														
A25RDDQNL11KC04	25	32,0	17,0	200	1/4-18 NPT	-11,0	-7,0	DN..110408	—	—	—	CM234R ASSY	SSP025016M	15 IP
A32SDDQNL15KC06	32	40,0	22,0	250	1/4-18 NPT	-12,0	-10,0	DN..150608	IDSN433	KMSP415IP	15 IP	CM234R ASSY	SSP025016M	15 IP
A40TDDQNL15KC06	40	50,0	27,0	300	1/4-18 NPT	-10,0	-10,0	DN..150608	IDSN433	KMSP415IP	15 IP	CM234R ASSY	SSP025016M	15 IP

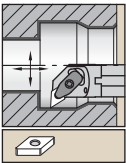

Steel shank with through coolant.

See pages B50–B58 and B176–B178 for inserts.

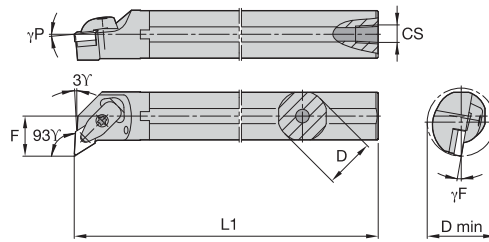

■ **A-DDUN-KC 93°**



catalogue number	D	D min	F	L1	CS	γF°	γP°	gage insert	shim	shim screw	Torx Plus	clamp assembly	slotted pin	Torx Plus
right hand														
A25RDDUNR11KC04	25	32,0	17,0	200	1/4-18 NPT	-12,0	-5,0	DN..110408	—	—	—	CM234R ASSY	SSP025016M	15 IP
A32SDDUNR11KC04	32	40,0	22,0	250	1/4-18 NPT	-12,0	-5,0	DN..110408	IDSN322	KMSP315IP	15 IP	CM234R ASSY	SSP025016M	15 IP
A32SDDUNR15KC06	32	40,0	22,0	250	1/4-18 NPT	-12,0	-6,0	DN..150608	IDSN433	KMSP415IP	15 IP	CM234R ASSY	SSP025016M	15 IP
A40TDDUNR15KC06	40	50,0	27,0	300	1/4-18 NPT	-9,0	-5,0	DN..150608	IDSN433	KMSP415IP	15 IP	CM234R ASSY	SSP025016M	15 IP
A50UDDUNR15KC06	50	63,0	35,0	350	1/4-18 NPT	-7,0	-5,0	DN..150608	IDSN433	KMSP415IP	15 IP	CM234R ASSY	SSP025016M	15 IP
left hand														
A25RDDUNL11KC04	25	32,0	17,0	200	1/4-18 NPT	-12,0	-5,0	DN..110408	—	—	—	CM234R ASSY	SSP025016M	15 IP
A32SDDUNL11KC04	32	40,0	22,0	250	1/4-18 NPT	-12,0	-5,0	DN..110408	IDSN322	KMSP315IP	15 IP	CM234R ASSY	SSP025016M	15 IP
A32SDDUNL15KC06	32	40,0	22,0	250	1/4-18 NPT	-12,0	-6,0	DN..150608	IDSN433	KMSP415IP	15 IP	CM234R ASSY	SSP025016M	15 IP
A40TDDUNL15KC06	40	50,0	27,0	300	1/4-18 NPT	-9,0	-5,0	DN..150608	IDSN433	KMSP415IP	15 IP	CM234R ASSY	SSP025016M	15 IP
A50UDDUNL15KC06	50	63,0	35,0	350	1/4-18 NPT	-7,0	-5,0	DN..150608	IDSN433	KMSP415IP	15 IP	CM234R ASSY	SSP025016M	15 IP

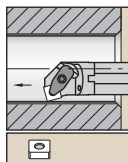

Steel shank with through coolant.

See pages B59–B66 and B178–B179 for inserts.

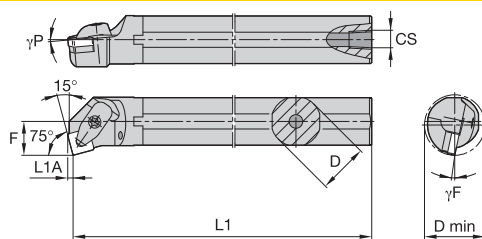

A-DSKN-KC 75°



O.D./I.D. Tooling

catalogue number	D	D min	F	L1	L1A	CS	γF°	γP°	gage insert	shim	shim screw	Torx Plus	clamp assembly	slotted pin	Torx Plus
right hand															
A25RDSKNR12KC04	25	32,0	17,0	200	3,0	1/4-18 NPT	-13,0	-15,0	SN..120408	—	—	—	CM234R ASSY	SSP025016M	15 IP
A32SDSKNR12KC04	32	40,0	22,0	250	3,0	1/4-18 NPT	-14,0	-5,0	SN..120408	ISSN433	KMSP415IP	15 IP	CM234R ASSY	SSP025016M	15 IP
A40TDSKNR12KC04	40	50,0	27,0	300	3,0	1/4-18 NPT	-9,0	-5,0	SN..120408	ISSN433	KMSP415IP	15 IP	CM234R ASSY	SSP025016M	15 IP
A40TDSKNR15KC06	40	50,0	27,0	300	3,7	1/4-18 NPT	-12,0	-5,0	SN..150612	ISSN533	KMSP515IP	15 IP	CM209R ASSY	SSP025018M	15 IP
left hand															
A25RDSKNL12KC04	25	32,0	17,0	200	3,0	1/4-18 NPT	-13,0	-15,0	SN..120408	—	—	—	CM234R ASSY	SSP025016M	15 IP
A32SDSKNL12KC04	32	40,0	22,0	250	3,0	1/4-18 NPT	-14,0	-5,0	SN..120408	ISSN433	KMSP415IP	15 IP	CM234R ASSY	SSP025016M	15 IP
A40TDSKNL12KC04	40	50,0	27,0	300	3,0	1/4-18 NPT	-9,0	-5,0	SN..120408	ISSN433	KMSP415IP	15 IP	CM234R ASSY	SSP025016M	15 IP
A40TDSKNL15KC06	40	50,0	27,0	300	3,7	1/4-18 NPT	-12,0	-5,0	SN..150612	ISSN533	KMSP515IP	15 IP	CM209R ASSY	SSP025018M	15 IP

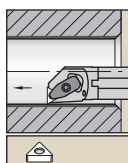

Steel shank with through coolant.

See pages B66–B73 and B179–B180 for inserts.

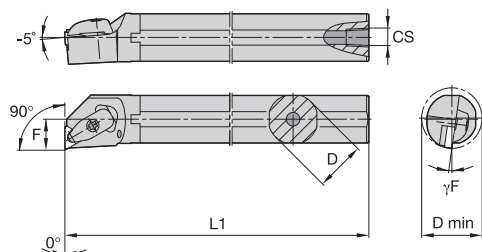

A-DTFN-KC 90°



catalogue number	D	D min	F	L1	CS	γF°	gage insert	shim	shim screw	Torx Plus	clamp assembly	slotted pin	Torx Plus
right hand													
A25RDTFNR16KC04	25	32,0	17,0	200	1/4-18 NPT	-14,0	TN..160408	ITSN323	KMSP315IP	15 IP	CM234R ASSY	SSP025016M	15 IP
A32SDTFNR16KC04	32	40,0	22,0	250	1/4-18 NPT	-12,0	TN..160408	ITSN323	KMSP315IP	15 IP	CM234R ASSY	SSP025016M	15 IP
left hand													
A25RDTFNL16KC04	25	32,0	17,0	200	1/4-18 NPT	-14,0	TN..160408	ITSN323	KMSP315IP	15 IP	CM234R ASSY	SSP025016M	15 IP
A32SDTFNL16KC04	32	40,0	22,0	250	1/4-18 NPT	-12,0	TN..160408	ITSN323	KMSP315IP	15 IP	CM234R ASSY	SSP025016M	15 IP

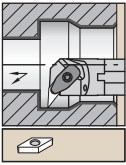

Steel shank
with through coolant.

See pages B74–B78 and
B180–B181 for inserts.

■ **A-DVUN-KC 93°**

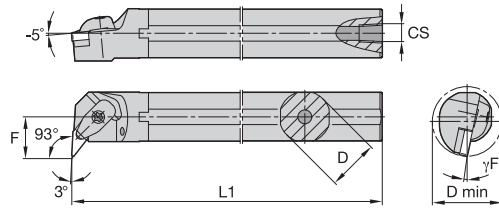

catalogue number	D	D min	F	L1	CS	γF°	gage insert	shim	shim screw	Torx Plus	clamp assembly	slotted pin	Torx Plus
right hand													
A32SDVUNR16KC04	32	40,0	22,0	250	1/4-18 NPT	-9.0	VN..160408	IVSN322	KMSP315IP	15 IP	CM234R ASSY	SSP025016M	15 IP
A40TDVUNR16KC04	40	50,0	27,0	300	1/4-18 NPT	-8.0	VN..160408	IVSN322	KMSP315IP	15 IP	CM215R ASSY	SSP025016M	15 IP
left hand													
A32SDVUNL16KC04	32	40,0	22,0	250	1/4-18 NPT	-9.0	VN..160408	IVSN322	KMSP315IP	15 IP	CM234R ASSY	SSP025016M	15 IP
A40TDVUNL16KC04	40	50,0	27,0	300	1/4-18 NPT	-8.0	VN..160408	IVSN322	KMSP315IP	15 IP	CM215R ASSY	SSP025016M	15 IP

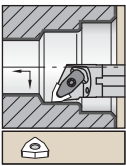

Steel shank
with through coolant.

See pages B79–B83 and
B181 for inserts.

■ **A-DWLN-KC 95°**

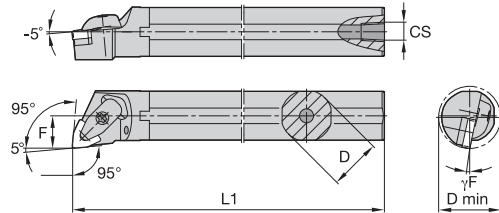

catalogue number	D	D min	F	L1	CS	γF°	gage insert	shim	shim screw	Torx Plus	clamp assembly	slotted pin	Torx Plus
right hand													
A25RDWLNLR06KC04	25	32,0	17,0	200	1/4-18 NPT	-14.0	WN..060408	—	—	—	CM234R ASSY	SSP025016M	15 IP
A25RDWLNLR08KC04	25	32,0	17,0	200	1/4-18 NPT	-12.0	WN..080408	—	—	—	CM234R ASSY	SSP025016M	15 IP
A32SDWLNLR08KC04	32	40,0	22,0	250	1/4-18 NPT	-14.0	WN..080408	IWSN433	KMSP415IP	15 IP	CM234R ASSY	SSP025016M	15 IP
A40TDWLNLR08KC04	40	50,0	27,0	300	1/4-18 NPT	-14.0	WN..080408	IWSN433	KMSP415IP	15 IP	CM234R ASSY	SSP025016M	15 IP
left hand													
A25RDWLNLR06KC04	25	32,0	17,0	200	1/4-18 NPT	-14.0	WN..060408	—	—	—	CM234R ASSY	SSP025016M	15 IP
A25RDWLNLR08KC04	25	32,0	17,0	200	1/4-18 NPT	-12.0	WN..080408	—	—	—	CM234R ASSY	SSP025016M	15 IP
A32SDWLNLR08KC04	32	40,0	22,0	250	1/4-18 NPT	-14.0	WN..080408	IWSN433	KMSP415IP	15 IP	CM234R ASSY	SSP025016M	15 IP
A40TDWLNLR08KC04	40	50,0	27,0	300	1/4-18 NPT	-14.0	WN..080408	IWSN433	KMSP415IP	15 IP	CM234R ASSY	SSP025016M	15 IP

O.D./I.D. Tooling

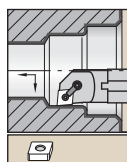

Steel shank with through coolant.

See pages B40–B49 and B174–B176 for inserts.

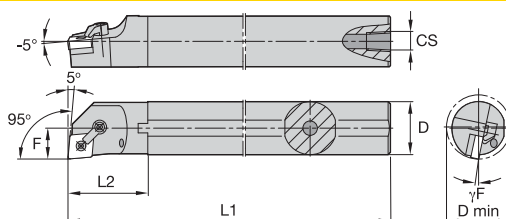

A-MCLN 95°



O.D./I.D. Tooling

catalogue number	D	D min	F	L1	L2	CS	γF°	gage insert	shim	lock pin	hex (mm)	clamp	clamp screw	hex (mm)	
right hand															
A25RMCLNR09	25	32,0	17,0	200	40	1/4-18 NPT	-12.0	CN..090308	—	KLM33	2 mm	CKM6	STCM5	2.5 mm	
A25RMCLNR12	25	32,0	17,0	200	33	1/4-18 NPT	-12.0	CN..120408	—	KLM43	2 mm	CKM21	STCM11	3 mm	
A32SMCLNR12	32	40,0	22,0	250	—	1/4-18 NPT	-14.0	CN..120408	ICSN432	KLM46	2.5 mm	CKM21	STCM20	3 mm	
A40TMCLNR12	40	50,0	27,0	300	—	1/4-18 NPT	-12.0	CN..120408	ICSN432	KLM46	2.5 mm	CKM21	STCM20	3 mm	
A40TMCLNR16	40	50,0	27,0	300	—	1/4-18 NPT	-11.0	CN..160608	ICSN533	KLM58	3 mm	CKM21	STCM20	3 mm	
A50UMCLNR12	50	63,0	35,0	350	—	1/4-18 NPT	-12.0	CN..120408	ICSN432	KLM46	2.5 mm	CKM21	STCM20	3 mm	
A50UMCLNR16	50	63,0	35,0	350	—	1/4-18 NPT	-12.0	CN..160608	ICSN533	KLM58	3 mm	CKM21	STCM20	3 mm	
A50UMCLNR19	50	63,0	35,0	350	—	1/4-18 NPT	-12.0	CN..190608	ICSN633	KLM68	4 mm	CKM12	STCM4	4 mm	
left hand															
A25RMCLNL12	25	32,0	17,0	200	33	1/4-18 NPT	-12.0	CN..120408	—	KLM43	2 mm	CKM21	STCM11	3 mm	
A32SMCLNL12	32	40,0	22,0	250	—	1/4-18 NPT	-14.0	CN..120408	ICSN432	KLM46	2.5 mm	CKM21	STCM20	3 mm	
A40TMCLNL12	40	50,0	27,0	300	—	1/4-18 NPT	-12.0	CN..120408	ICSN432	KLM46	2.5 mm	CKM21	STCM20	3 mm	
A40TMCLNL16	40	50,0	27,0	300	—	1/4-18 NPT	-11.0	CN..160608	ICSN533	KLM58	3 mm	CKM21	STCM20	3 mm	
A50UMCLNL12	50	63,0	35,0	350	—	1/4-18 NPT	-12.0	CN..120408	ICSN432	KLM46	2.5 mm	CKM21	STCM11	3 mm	
A50UMCLNL16	50	63,0	35,0	350	—	1/4-18 NPT	-12.0	CN..160608	ICSN533	KLM58	3 mm	CKM21	STCM20	3 mm	
A50UMCLNL19	50	63,0	35,0	350	—	1/4-18 NPT	-12.0	CN..190608	ICSN633	KLM68	4 mm	CKM12	STCM4	4 mm	

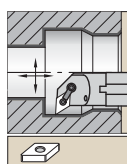

Steel shank with through coolant.

See pages B50–B58 and B176–B178 for inserts.

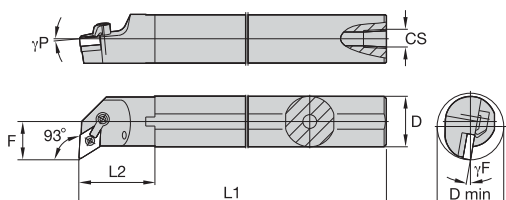

A-MDUN 93°



catalogue number	D	D min	F	L1	L2	CS	γF°	γP°	gage insert	shim	lock pin	hex (mm)	clamp	clamp screw	hex (mm)
right hand															
A25RMDUNR11	25	32,0	17,0	200	40	1/4-18 NPT	-14.0	-5.0	DN..110408	—	KLM33L	2 mm	CKM7	STCM5	2.5 mm
A25RMDUNR15	25	32,0	17,0	200	—	1/4-18 NPT	-14.0	-5.0	DN..150408	IDSN432	KLM46L	2.5 mm	CKM22	STCM11	3 mm
A32SMDUNR11	32	40,0	22,0	250	50	1/4-18 NPT	-12.0	-5.0	DN..110408	IDSN322	KLM34L	2 mm	CKM7	STCM5	2.5 mm
A32SMDUNR15	32	40,0	22,0	250	—	1/4-18 NPT	-12.0	-6.0	DN..150608	IDSN432	KLM46L	2.5 mm	CKM22	STCM20	3 mm
A40TMDUNR15	40	50,0	27,0	300	—	1/4-18 NPT	-9.0	-5.0	DN..150608	IDSN432	KLM46L	2.5 mm	CKM22	STCM20	3 mm
A50UMDUNR15	50	63,0	35,0	350	—	1/4-18 NPT	-7.0	-5.0	DN..150608	IDSN432	KLM46L	2.5 mm	CKM22	STCM20	3 mm
left hand															
A25RMDUNL11	25	32,0	17,0	200	40	1/4-18 NPT	-14.0	-5.0	DN..110408	—	KLM33L	2 mm	CKM7	STCM5	2.5 mm
A25RMDUNL15	25	32,0	17,0	200	—	1/4-18 NPT	-14.0	-5.0	DN..150408	IDSN432	KLM46L	2.5 mm	CKM22	STCM11	3 mm
A32SMDUNL11	32	40,0	22,0	250	50	1/4-18 NPT	-12.0	-5.0	DN..110408	IDSN322	KLM34L	2 mm	CKM7	STCM5	2.5 mm
A32SMDUNL15	32	40,0	22,0	250	—	1/4-18 NPT	-12.0	-6.0	DN..150608	IDSN432	KLM46L	2.5 mm	CKM22	STCM20	3 mm
A40TMDUNL15	40	50,0	27,0	300	—	1/4-18 NPT	-9.0	-5.0	DN..150608	IDSN432	KLM46L	2.5 mm	CKM22	STCM20	3 mm
A50UMDUNL15	50	63,0	35,0	350	—	1/4-18 NPT	-7.0	-5.0	DN..150608	IDSN432	KLM46L	2.5 mm	CKM22	STCM20	3 mm



Steel shank with through coolant.

See pages B59–B66 and B178–B179 for inserts.

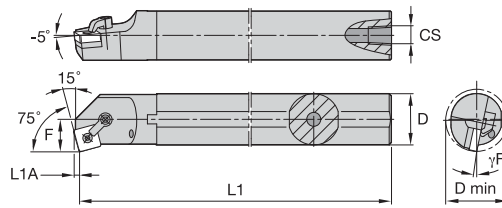

■ A-MSKN 75°



catalogue number	D	D min	F	L1	L1A	CS	γF°	gage insert	shim	lock pin	hex (mm)	clamp	clamp screw	hex (mm)
right hand														
A25RMSKNR12	25	32,0	17,0	200	3,1	1/4-18 NPT	-14.0	SN..120408	—	KLM43	2 mm	CKM21	STCM11	3 mm
A32SMSKNR12	32	40,0	22,0	250	3,1	1/4-18 NPT	-14.0	SN..120408	ISSN432	KLM46	2.5 mm	CKM21	STCM20	3 mm
A40TMSKNR12	40	50,0	27,0	300	3,1	1/4-18 NPT	-10.0	SN..120408	ISSN432	KLM46	2.5 mm	CKM21	STCM20	3 mm
A40TMSKNR15	40	50,0	27,0	300	4,1	1/4-18 NPT	-14.0	SN..150608	ISSN533	KLM58	3 mm	CKM21	STCM20	3 mm
A50UMSKNR19	50	63,0	35,0	350	4,6	1/4-18 NPT	-12.0	SN..190608	ISSN633	KLM68	4 mm	CKM12	STCM4	4 mm
left hand														
A25RMSKNL12	25	32,0	17,0	200	3,1	1/4-18 NPT	-14.0	SN..120408	—	KLM43	2 mm	CKM21	STCM11	3 mm
A32SMSKNL12	32	40,0	22,0	250	3,1	1/4-18 NPT	-14.0	SN..120408	ISSN432	KLM46	2.5 mm	CKM21	STCM20	3 mm
A40TMSKNL12	40	50,0	27,0	300	3,1	1/4-18 NPT	-10.0	SN..120408	ISSN432	KLM46	2.5 mm	CKM21	STCM20	3 mm
A40TMSKNL15	40	50,0	27,0	300	4,1	1/4-18 NPT	-14.0	SN..150608	ISSN533	KLM58	3 mm	CKM21	STCM20	3 mm
A50UMSKNL19	50	63,0	35,0	350	4,6	1/4-18 NPT	-12.0	SN..190608	ISSN633	KLM68	4 mm	CKM12	STCM4	4 mm

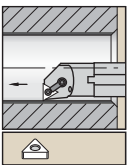

Steel shank with through coolant.

See pages B66–B73 and B179–B180 for inserts.

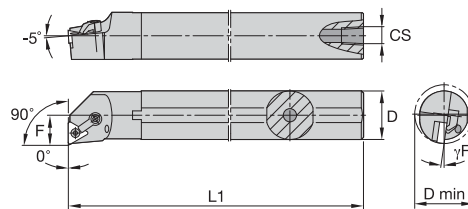

■ A-MTFN 90°



catalogue number	D	D min	F	L1	CS	γF°	gage insert	shim	lock pin	hex (mm)	clamp	clamp screw	hex (mm)
right hand													
A25RMTFNR16	25	32,0	17,0	200	1/4-18 NPT	-14.0	TN..160408	ITSN322	KLM34L	2 mm	CKM21	STCM20	3 mm
A32SMTFNR16	32	40,0	22,0	250	1/4-18 NPT	-12.0	TN..160408	ITSN322	KLM34L	2 mm	CKM21	STCM20	3 mm
A40TMTFNR16	40	50,0	27,0	300	1/4-18 NPT	-9.0	TN..160408	ITSN322	KLM34L	2 mm	CKM21	STCM20	3 mm
A50UMTFNR22	50	63,0	35,0	350	1/4-18 NPT	-7.0	TN..220412	ITSN433	KLM46	2.5 mm	CKM9	STCM4	4 mm
left hand													
A25RMTFNL16	25	32,0	17,0	200	1/4-18 NPT	-14.0	TN..160408	ITSN322	KLM34L	2 mm	CKM21	STCM20	3 mm
A32SMTFNL16	32	40,0	22,0	250	1/4-18 NPT	-12.0	TN..160408	ITSN322	KLM34L	2 mm	CKM21	STCM20	3 mm
A40TMTFNL16	40	50,0	27,0	300	1/4-18 NPT	-9.0	TN..160408	ITSN322	KLM34L	2 mm	CKM21	STCM20	3 mm
A50UMTFNL22	50	63,0	35,0	350	1/4-18 NPT	-7.0	TN..220412	ITSN433	KLM46	2.5 mm	CKM9	STCM4	4 mm

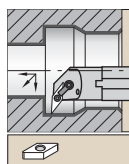

Steel shank with through coolant.

See pages B74–B78 and B180–B181 for inserts.

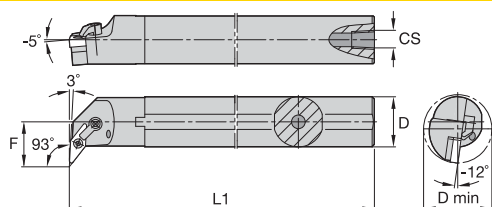

A-MVUN 93°



O.D./I.D. Tooling

catalogue number	D	D min	F	L1	CS	gage insert	shim	lock pin	hex (mm)	clamp	clamp screw	hex (mm)
right hand												
A25RMVUNR16	25	37,0	22,0	200	1/4-18 NPT	VN..160408	IWSN322	KLM34L	2 mm	CKM31	STCM26	3 mm
A32SMVUNR16	32	40,0	22,0	250	1/4-18 NPT	VN..160408	IWSN322	KLM34L	2 mm	CKM31	STCM20	3 mm
left hand												
A25RMVUNL16	25	37,0	22,0	200	1/4-18 NPT	VN..160408	IWSN322	KLM34L	2 mm	CKM31	STCM26	3 mm
A32SMVUNL16	32	40,0	22,0	250	1/4-18 NPT	VN..160408	IWSN322	KLM34L	2 mm	CKM31	STCM20	3 mm

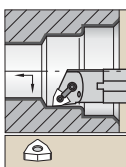

Steel shank with through coolant.

See pages B79–B83 and B181 for inserts.

A-MWLN 95°

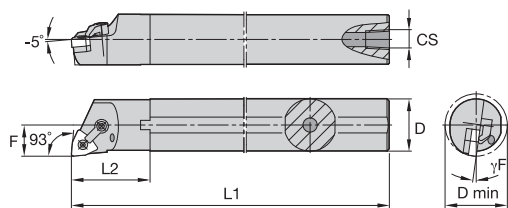

catalogue number	D	D min	F	L1	L2	CS	γF°	gage insert	shim	lock pin	hex (mm)	clamp	clamp screw	hex (mm)
right hand														
A25RMWLNRO6	25	32,0	17,0	200	—	1/4-18 NPT	-12.0	WN..060408	—	KLM33L	2 mm	CKM6	STCM5	2.5 mm
A25RMWLNRO8	25	32,0	17,0	200	40	1/4-18 NPT	-12.0	WN..080408	—	KLM43	2 mm	CKM20	STCM11	3 mm
A32SMWLNRO6	32	40,0	22,0	250	—	1/4-18 NPT	-10.0	WN..060408	IWSN322	KLM34L	2 mm	CKM6	STCM5	2.5 mm
A32SMWLNRO8	32	40,0	22,0	250	50	1/4-18 NPT	-14.0	WN..080408	IWSN433	KLM46	2.5 mm	CKM20	STCM20	3 mm
A40TMWLNRO8	40	50,0	27,0	300	55	1/4-18 NPT	-12.0	WN..080408	IWSN433	KLM46	2.5 mm	CKM20	STCM20	3 mm
left hand														
A25RMWLNLO6	25	32,0	17,0	200	—	1/4-18 NPT	-12.0	WN..060408	—	KLM33L	2 mm	CKM6	STCM5	2.5 mm
A25RMWLNLO8	25	32,0	17,0	200	40	1/4-18 NPT	-12.0	WN..080408	—	KLM43	2 mm	CKM20	STCM11	3 mm
A32SMWLNLO6	32	40,0	22,0	250	—	1/4-18 NPT	-10.0	WN..060408	IWSN322	KLM34L	2 mm	CKM6	STCM5	2.5 mm
A32SMWLNLO8	32	40,0	22,0	250	50	1/4-18 NPT	-14.0	WN..080408	IWSN433	KLM46	2.5 mm	CKM20	STCM20	3 mm
A40TMWLNLO8	40	50,0	27,0	300	55	1/4-18 NPT	-12.0	WN..080408	IWSN433	KLM46	2.5 mm	CKM20	STCM20	3 mm

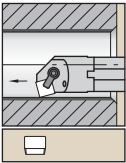

Steel shank
with through coolant.

See pages B85–B86 and
B130 for inserts.

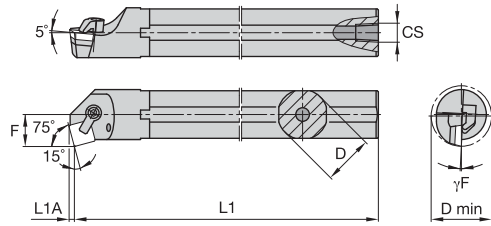

■ **A-CSKP 75°**



catalogue number	D	D min	F	L1	L1A	CS	γF°	gage insert	shim	shim screw	hex (mm)	clamp	clamp screw	hex (mm)	
right hand															
A25RCSKPR12	25	32,0	17,0	200	3,1	1/4-18 NPT	-2.0	SP..120308	SM840	MS110	2 mm	CKM20	STCM11	3 mm	
A32SCKPR12	32	40,0	22,0	250	3,1	1/4-18 NPT	0.0	SP..120308	SM840	MS110	2 mm	CKM10	STCM8	4 mm	
left hand															
A25RCSKPL12	25	32,0	17,0	200	3,1	1/4-18 NPT	-2.0	SP..120308	SM840	MS110	2 mm	CKM20	STCM11	3 mm	
A32SCKPL12	32	40,0	22,0	250	3,1	1/4-18 NPT	0.0	SP..120308	SM840	MS110	2 mm	CKM10	STCM8	4 mm	

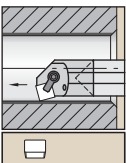

Carbide shank
with through coolant.

See pages B85–B86 and
B130 for inserts.

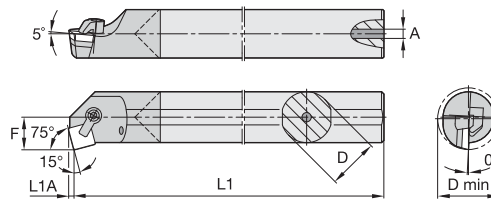

■ **E-CSKP 75°**



catalogue number	D	D min	F	L1	L1A	A	gage insert	shim	shim screw	clamp	clamp screw	hex (mm)
right hand												
E16RCSKPR09	16	20,0	11,0	200	2,2	5,5	SP..090308	SM821	MS963	CKM19	STCM9	2.5 mm
left hand												
E16RCSKPL09	16	20,0	11,0	200	2,2	5,5	SP..090308	SM821	MS963	CKM19	STCM9	2.5 mm

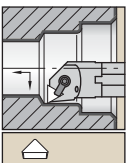

Steel shank
with through coolant.

See pages B86–B87 and
B136 for inserts.

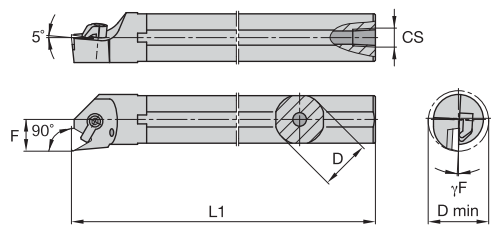

■ **A-CTFP 90°**



catalogue number	D	D min	F	L1	CS	γF°	gage insert	shim	shim screw	hex (mm)	clamp	clamp screw	hex (mm)
right hand													
A16RCTFPR11	16	20,0	11,0	200	1/8-27 NPT	-4.0	TP..110304	—	—	—	CKM19	STCM9	2.5 mm
A20QCTFPR11	20	25,0	13,0	180	1/8-27 NPT	0.0	TP..110304	SM815	MS961	—	CKM19	STCM9	2.5 mm
A25RCTFPR16	25	32,0	17,0	200	1/4-18 NPT	-3.0	TP..160308	SM841	MS110	2 mm	CKM10	STCM8	4 mm
A32SCTFPR16	32	40,0	22,0	250	1/4-18 NPT	-3.0	TP..160308	SM841	MS110	2 mm	CKM10	STCM8	4 mm
A40VCTFPR16	40	48,0	27,0	400	1/4-18 NPT	-3.0	TP..160308	SM841	MS110	2 mm	CKM10	STCM8	4 mm

(continued)

(A-CTFP 90° continued)

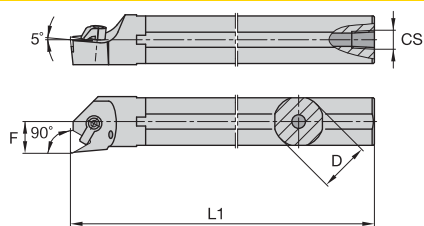

O.D./I.D. Tooling

catalogue number	D	D min	F	L1	CS	γF°	gage insert	shim	shim screw	hex (mm)	clamp	clamp screw	hex (mm)
left hand													
A16RCTFPL11	16	20,0	11,0	200	1/8-27 NPT	-4.0	TP..110304	—	—	—	CKM19	STCM9	2.5 mm
A20QCTFPL11	20	25,0	13,0	180	1/8-27 NPT	0.0	TP..110304	SM815	MS961	—	CKM19	STCM9	2.5 mm
A25RCTFPL16	25	32,0	17,0	200	1/4-18 NPT	-3.0	TP..160308	SM841	MS110	2 mm	CKM10	STCM8	4 mm
A32SCTFPL16	32	40,0	22,0	250	1/4-18 NPT	-3.0	TP..160308	SM841	MS110	2 mm	CKM10	STCM8	4 mm
A40VCTFPL16	40	48,0	27,0	400	1/4-18 NPT	-3.0	TP..160308	SM841	MS110	2 mm	CKM10	STCM8	4 mm

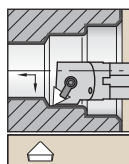

Steel shank with through coolant.
See pages B86–B87 and B130 for inserts.

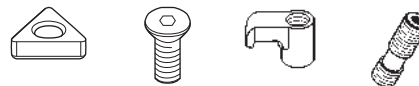
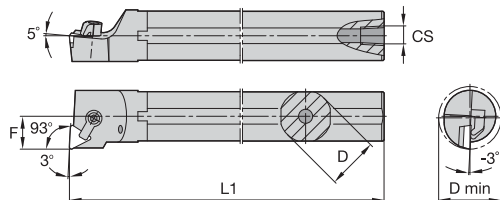

■ **A-CTUP 93°**

catalogue number	D	D min	F	L1	CS	gage insert	shim	shim screw	clamp	clamp screw	hex (mm)
right hand											
A16MCTUPR11	16	20,0	11,0	150	1/8-27 NPT	TP..110304	SM815	MS961	CKM19	STCM9	2.5 mm
left hand											
A16MCTUPL11	16	20,0	11,0	150	1/8-27 NPT	TP..110304	SM815	MS961	CKM19	STCM9	2.5 mm
A20QCTUPL11	20	25,0	13,0	180	1/8-27 NPT	TP..110304	SM815	MS961	CKM19	STCM9	2.5 mm

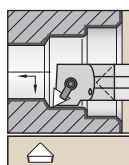

Carbide shank with through coolant.
See pages B86–B87 and B130 for inserts.

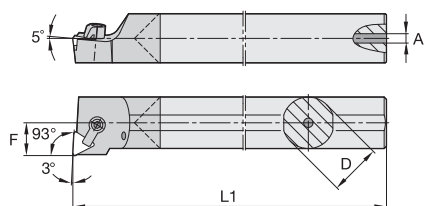

■ **E-CTUP 93°**

catalogue number	D	D min	F	L1	A	gage insert	shim	shim screw	clamp	clamp screw	hex (mm)
right hand											
E16RCTUPR11	16	20,0	11,0	200	5,5	TP..110304	SM815	MS961	CKM19	STCM9	2.5 mm
left hand											
E16RCTUPL11	16	20,0	11,0	200	5,5	TP..110304	SM815	MS961	CKM19	STCM9	2.5 mm

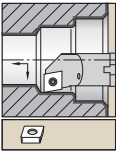

Steel shank with through coolant.

See pages B88–B91 and B187–B188 for inserts.

■ A-SCFC 90°

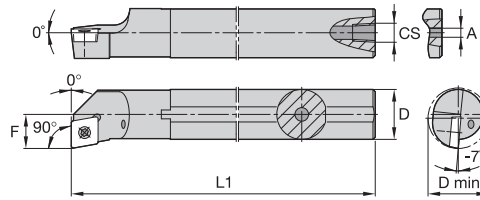

catalogue number	D	D min	F	L1	CS	gage insert	insert screw	Torx
right hand								
A25TSCFCR12	25	32,0	17,0	300	1/4-18 NPT	CC..120408	MS1157	T15
left hand								
A25TSCFCL12	25	32,0	17,0	300	1/4-18 NPT	CC..120408	MS1157	T15

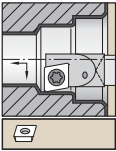

Carbide shank with through coolant.

See pages B91–B92 and B189 for inserts.

■ E-SCFD 90°

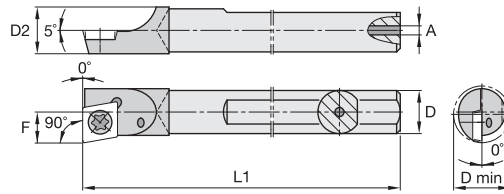

catalogue number	D	D min	D2	F	L1	A	gage insert	insert screw	Torx
right hand									
E05HSCFDRS4	5	5,9	5,2	3,0	102	1,0	CD..S4T002	CC09	T6
E06HSCFDRS4	6	7,1	6,2	3,7	100	1,2	CD..S4T002	CC11	T6

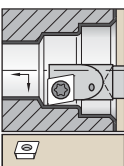

Necked steel shank with through coolant.

See pages B91–B92 and B189 for inserts.

■ A-SCFD 90°

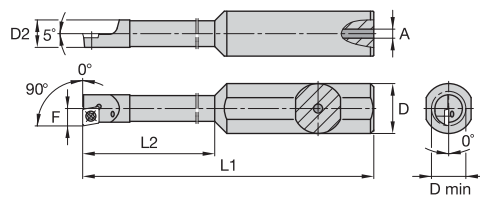

catalogue number	D	D min	D2	F	L1	L2	A	gage insert	insert screw	Torx
right hand										
A0510ESCFDRS412	10	5,9	5,16	3,1	70	12,7	1,0	CD..S4T002	CC11	T6
A0510ESCFDRS425	10	5,9	5,16	3,1	70	25,4	1,0	CD..S4T002	CC11	T6
A0612ESCFDRS431	12	7,4	6,60	3,9	70	31,7	1,0	CD..S4T002	CC11	T6

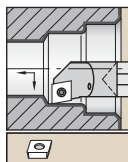

Necked carbide shank with through coolant.

See pages B91–B92 and B189 for inserts.

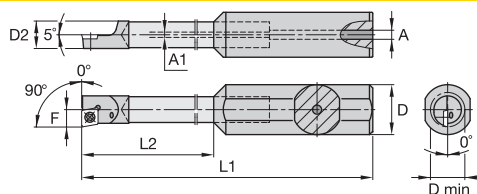

■ E-SCFD 90°



O.D./I.D. Tooling

catalogue number	D	D min	D2	F	L1	L2	A	A1	gage insert	insert screw	Torx
right hand											
E0512XSCFDRS425	12	6,1	5,30	3,2	64	25,4	3,18	1,0	CD..S4T002	CC11	T6
E0512XSCFDRS450	12	6,1	5,30	3,2	89	50,8	3,18	1,0	CD..S4T002	CC11	T6
E0616XSCFDRS463	16	7,4	6,50	3,9	127	63,5	3,18	1,2	CD..S4T002	CC11	T6

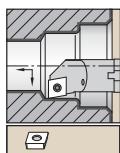

Steel shank with through coolant.

See pages B92–B95 and B189–B190 for inserts.

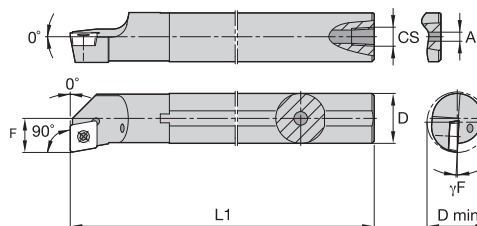

■ A-SCFP 90°



catalogue number	D	D min	F	L1	A	CS	γF°	gage insert	insert screw	Torx
right hand										
A08JSCFPR06	8	11,0	6,0	110	2,4	—	-8.0	CP..060204	MS1153	T7
A10KSCFPR06	10	13,0	7,0	125	3,2	—	-6.0	CP..060204	MS1153	T7
A12MSCFPR06	12	16,0	9,0	150	—	1/16-27 NPT	-4.0	CP..060204	MS1153	T7
A16RSCFPR06	16	20,0	11,0	200	—	1/8-27 NPT	-5.0	CP..060203	MS1153	T7
A16RSCFPR09	16	20,0	11,0	200	—	1/8-27 NPT	-4.0	CP..09T308	MS1155	T15
A20SSCFPR06	20	25,0	13,0	250	—	1/8-27 NPT	-3.0	CP..060203	MS1153	T7
A20SSCFPR09	20	25,0	13,0	250	—	1/8-27 NPT	-2.0	CP..09T308	MS1155	T15
left hand										
A08JSCFPL06	8	11,0	6,0	110	2,4	—	-8.0	CP..060204	MS1153	T7
A10KSCFPL06	10	13,0	7,0	125	3,2	—	-6.0	CP..060204	MS1153	T7
A12MSCFPL06	12	16,0	9,0	150	—	1/16-27 NPT	-4.0	CP..060204	MS1153	T7
A16RSCFPL06	16	20,0	11,0	200	—	1/8-27 NPT	-5.0	CP..060203	MS1153	T7
A16RSCFPL09	16	20,0	11,0	200	—	1/8-27 NPT	-4.0	CP..09T308	MS1155	T15
A20SSCFPL06	20	25,0	13,0	250	—	1/8-27 NPT	-3.0	CP..060203	MS1153	T7
A20SSCFPL09	20	25,0	13,0	250	—	1/8-27 NPT	-2.0	CP..09T308	MS1155	T15

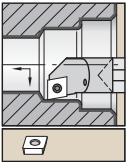

Carbide shank
with through coolant.
See pages B92–B95 and
B189–B190 for inserts.

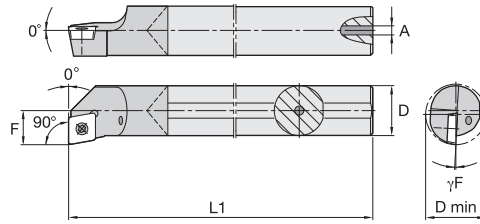

■ E-SCFP 90°



catalogue number	D	D min	F	L1	A	γF°	gage insert	insert screw	Torx
right hand									
E08KSCFP06A	8	11,0	6,0	125,0	2,4	-8,0	CP..060204	MS1939	T7
E10MSCFP06A	10	13,0	7,0	150,0	3,2	-4,0	CP..060204	MS1939	T7
E12QSCFP06	12	16,0	9,0	180,0	4,8	-3,0	CP..060204	MS1153	T7
left hand									
E08KSCFPL06A	8	11,0	6,0	125,0	2,4	-8,0	CP..060204	MS1939	T7
E10MSCFPL06A	10	13,0	7,0	150,0	3,2	-4,0	CP..060204	MS1939	T7
E12QSCFPL06	12	16,0	9,0	180,0	4,8	-3,0	CP..060204	MS1153	T7

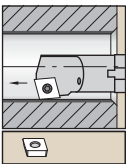

Steel shank
with through coolant.
See pages B92–B95 and
B189–B190 for inserts.

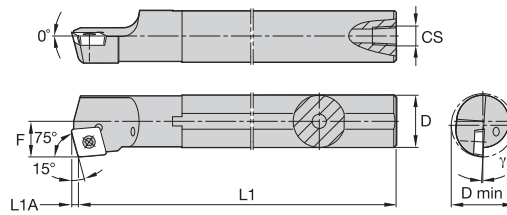

■ A-SCKP 75°



catalogue number	D	D min	F	L1	L1A	CS	γF°	gage insert	insert screw	Torx
right hand										
A16RSCKPR09	16	20,0	11,0	200	2,3	1/8-27 NPT	-4,0	CP..09T308	MS1155	T15
A20SSCKPR09	20	25,0	13,0	250	2,3	1/8-27 NPT	-3,0	CP..09T308	MS1155	T15
left hand										
A16RSCKPL09	16	20,0	11,0	200	2,3	1/8-27 NPT	-4,0	CP..09T308	MS1155	T15
A20SSCKPL09	20	25,0	13,0	250	2,3	1/8-27 NPT	-3,0	CP..09T308	MS1155	T15

O.D./I.D. Tooling

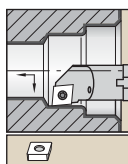

Steel shank with through coolant.

See pages B88–B91 and B187–B188 for inserts.

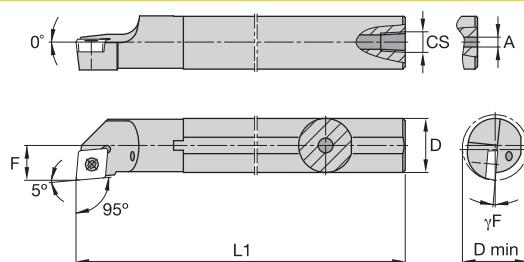

■ A-SCLC 95°

O.D./I.D. Tooling

catalogue number	D	D min	F	L1	A	CS	γF°	gage insert	shim	shim screw	hex (mm)	insert screw	Torx
right hand													
A08JSCLCR06	8	11,0	6,0	110	2,4	—	-8.0	CC..060204	—	—	—	MS1939	T7
A10KSCLCR06	10	13,0	7,0	125	3,2	—	-7.0	CC..060204	—	—	—	MS1153	T7
A12MSCLCR06	12	16,0	9,0	150	4,0	1/16-27 NPT	-6.0	CC..060204	—	—	—	MS1153	T7
A16RSCLCR09	16	20,0	11,0	200	—	1/8-27 NPT	-7.0	CC..09T308	—	—	—	MS1155	T15
A20SSCLCR09	20	25,0	13,0	250	—	1/8-27 NPT	-5.0	CC..09T308	—	—	—	MS1155	T15
A25TSCLCR12	25	32,0	17,0	300	—	1/4-18 NPT	-7.0	CC..120408	—	—	—	MS1157	T15
A32TSCLCR12	32	40,0	22,0	300	—	1/4-18 NPT	-7.0	CC..120408	SKCP453	SRS4	4 mm	MS1158	T15
left hand													
A08JSCLCL06	8	11,0	6,0	110	2,4	—	-8.0	CC..060204	—	—	—	MS1939	T7
A10KSCLCL06	10	13,0	7,0	125	3,2	—	-7.0	CC..060204	—	—	—	MS1153	T7
A12MSCLCL06	12	16,0	9,0	150	4,0	1/16-27 NPT	-6.0	CC..060204	—	—	—	MS1153	T7
A16RSCLCL09	16	20,0	11,0	200	—	1/8-27 NPT	-7.0	CC..09T308	—	—	—	MS1155	T15
A20SSCLCL09	20	25,0	13,0	250	—	1/8-27 NPT	-5.0	CC..09T308	—	—	—	MS1155	T15
A25TSCLCL12	25	32,0	17,0	300	—	1/4-18 NPT	-7.0	CC..120408	—	—	—	MS1157	T15
A32TSCLCL12	32	40,0	22,0	300	—	1/4-18 NPT	-7.0	CC..120408	SKCP453	SRS4	4 mm	MS1158	T15

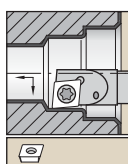

Steel shank with through coolant.

See pages B91–B92 and B189 for inserts.

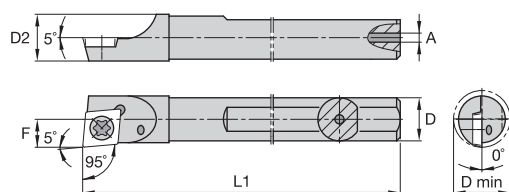

■ A-SCLD 95°

catalogue number	D	D min	D2	F	L1	A	gage insert	insert screw	Torx
right hand									
A04XSCLDRS4	4	4,6	4,2	2,4	65	1,0	CD..S4T002	CC09	T6
A05XSCLDRS4	5	5,8	5,2	3,0	65	1,0	CD..S4T002	CC09	T6
A06XSCLDRS4	6	7,1	6,2	3,7	64	1,0	CD..S4T002	CC11	T6
A08XSCLDRS4	8	9,1	8,2	4,7	76	2,0	CD..S4T002	CC11	T6
left hand									
A04XSCLDLS4	4	4,6	4,2	2,4	65	1,0	CD..S4T002	CC09	T6
A05XSCLDLS4	5	5,8	5,2	3,0	65	1,0	CD..S4T002	CC09	T6
A06XSCLDLS4	6	6,9	6,2	3,7	65	1,0	CD..S4T002	CC11	T6
A08XSCLDLS4	8	9,1	8,2	4,7	76	2,0	CD..S4T002	CC11	T6

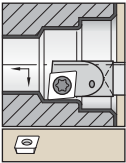

Carbide shank with through coolant.

See pages B91–B92 and B189 for inserts.

■ E-SCLD 95°

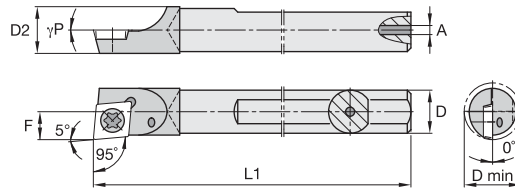

catalogue number	D	D min	D2	F	L1	A	γP°	gage insert	insert screw	Torx
right hand										
E04HSCLDRS4	4	4,6	—	2,4	100	1,0	0,0	CD..S4T002	CC09	T6
E04MSCLDRS4	4	4,6	4,2	2,4	150	1,0	0,0	CD..S4T002	CC09	T6
E05HSCLDRS4	5	5,9	—	3,0	101	1,0	5,0	CD..S4T002	CC09	T6
E05MSCLDRS4	5	5,9	5,2	3,0	150	1,0	0,0	CD..S4T002	CC09	T6
E06HSCLDRS4	6	7,1	6,2	3,7	100	1,2	0,0	CD..S4T002	CC11	T6
E06MSCLDRS4	6	7,1	6,2	3,7	150	1,2	0,0	CD..S4T002	CC11	T6
E08MSCLDRS4	8	9,1	—	4,7	150	2,4	5,0	CD..120605	CC11	T6
left hand										
E04HSCLDLS4	4	4,6	4,2	2,4	100	1,0	0,0	CD..S4T002	CC09	T6
E04MSCLDLS4	4	4,6	4,2	2,4	150	1,0	0,0	CD..S4T002	CC09	T6
E05HSCLDLS4	5	5,9	5,2	3,0	100	1,0	0,0	CD..S4T002	CC09	T6
E05MSCLDLS4	5	5,9	5,2	3,0	150	1,0	0,0	CD..S4T002	CC09	T6
E06HSCLDLS4	6	7,1	6,2	3,7	100	1,2	0,0	CD..S4T002	CC11	T6
E06MSCLDLS4	6	7,1	6,2	3,7	150	1,2	0,0	CD..S4T002	CC11	T6
E08MSCLDLS4	8	9,1	8,2	4,7	150	2,4	0,0	CD..S4T002	CC11	T6

O.D./I.D. Tooling

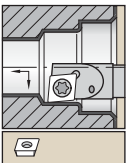

Necked steel shank with through coolant.

See pages B91–B92 and B189 for inserts.

■ A-SCLD 95°

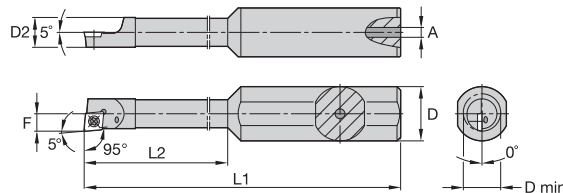

catalogue number	D	D min	D2	F	L1	L2	A	gage insert	insert screw	Torx
right hand										
A0410ESCLDRS412	10	5,2	4,57	2,6	70	12,7	1,0	CD..S4T002	CC09	T6
A0410ESCLDRS425	10	5,2	4,70	2,6	70	25,4	1,0	CD..S4T002	CC09	T6
A0412ESCLDRS412	12	5,2	4,57	2,6	70	12,7	1,0	CD..S4T002	CC09	T6
A0412ESCLDRS425	12	5,2	4,57	2,6	70	25,4	1,0	CD..S4T002	CC09	T6
A0510ESCLDRS412	10	5,8	5,16	3,0	70	12,7	1,0	CD..S4T002	CC11	T6
A0510ESCLDRS425	10	5,8	5,16	3,0	70	25,4	1,0	CD..S4T002	CC11	T6
A0510GSCLDRS4	10	6,0	—	3,2	90	25,0	3,2	CD..S4T002	MS1454	T5
A0610HSCLDRS4	10	7,6	—	3,8	100	32,0	3,2	CD..S4T002	MS1454	T5
A0612ESCLDRS419	12	7,2	6,60	3,7	70	19,1	1,0	CD..S4T002	CC11	T6

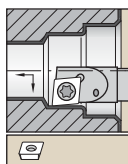

Necked carbide shank with through coolant.

See pages B91–B92 and B189 for inserts.

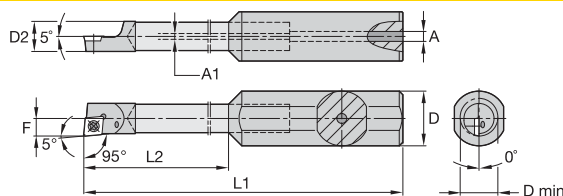

■ E-SCLD 95°



O.D./I.D. Tooling

catalogue number	D	D min	D2	F	L1	L2	A	gage insert	insert screw	Torx
right hand										
E0412DSCLDRS422	12	5,3	4,80	2,6	60	22,2	3,18	CD..S4T002	CC09	T6
E0412XSCLDRS447	12	5,3	4,80	2,6	86	47,6	3,18	CD..S4T002	CC09	T6
E0416KSCLDRS447	16	5,3	4,80	2,6	124	47,6	3,18	CD..S4T002	CC09	T6
E0512XSCLDRS425	12	5,9	5,30	3,0	64	25,4	3,18	CD..S4T002	CC11	T6
E0612ESCLDRS431	12	7,2	6,56	3,7	70	31,7	3,18	CD..S4T002	CC11	T6
E0612HSCLDRS463	12	7,2	6,56	3,7	100	63,5	3,18	CD..S4T002	CC11	T6
E0616HSCLDRS431	16	7,2	6,56	3,7	95	31,7	3,18	CD..S4T002	CC11	T6
E0616XSCLDRS463	16	7,2	6,56	3,7	133	63,5	3,18	CD..S4T002	CC11	T6

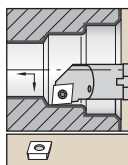

Steel shank with through coolant.

See pages B92–B95 and B189–B190 for inserts.

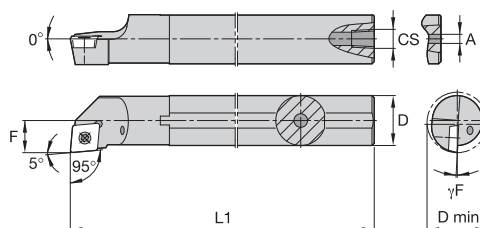

■ A-SCLP 95°



catalogue number	D	D min	F	L1	A	CS	γF°	gage insert	insert screw	Torx
right hand										
A08JSCLPR06	8	11,0	6,0	110	2,4	—	-6.0	CP..060204	MS1939	T7
A10KSCLPR06	10	13,0	7,0	125	3,2	—	-4.0	CP..060204	MS1939	T7
A12MSCLPR06	12	16,0	9,0	150	4,0	1/16-27 NPT	-3.0	CP..060204	MS1153	T7
A16RSCLPR06	16	20,0	11,0	200	—	1/8-27 NPT	-5.0	CP..060203	MS1153	T7
A16RSCLPR09	16	20,0	11,0	200	—	1/8-27 NPT	-4.0	CP..09T308	MS1155	T15
A20SSCLPR06	20	25,0	13,0	250	—	1/8-27 NPT	-3.0	CP..060203	MS1153	T7
A20SSCLPR09	20	25,0	13,0	250	—	1/8-27 NPT	-2.0	CP..09T308	MS1155	T15
left hand										
A08JSCLPL06	8	11,0	6,0	110	2,4	—	-6.0	CP..060204	MS1939	T7
A10KSCLPL06	10	13,0	7,0	125	3,2	—	-4.0	CP..060204	MS1939	T7
A12MSCLPL06	12	16,0	9,0	150	4,0	1/16-27 NPT	-3.0	CP..060204	MS1153	T7
A16RSCLPL06	16	20,0	11,0	200	—	1/8-27 NPT	-5.0	CP..060203	MS1153	T7
A16RSCLPL09	16	20,0	11,0	200	—	1/8-27 NPT	-4.0	CP..09T308	MS1155	T15
A20SSCLPL06	20	25,0	13,0	250	—	1/8-27 NPT	-3.0	CP..060203	MS1153	T7
A20SSCLPL09	20	25,0	13,0	250	—	1/8-27 NPT	-2.0	CP..09T308	MS1155	T15

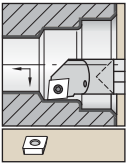

Carbide shank with through coolant.
See pages B92–B95 and B189–B190 for inserts.

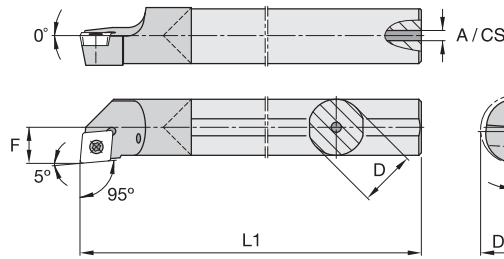

■ **E-SCLP 95°**



catalogue number	D	D min	F	L1	A	γF°	gage insert	insert screw	Torx
right hand									
E08KSCLPR06A	8	11,0	6,0	122	2,4	-6.0	CP..060204	MS1939	T7
E10MSCLPR06A	10	13,0	7,0	150	3,2	-4.0	CP..060204	MS1939	T7
E12QSCLPR06	12	16,0	9,0	180	4,8	-3.0	CP..060204	MS1153	T7
E16RSCLPR09	16	20,0	11,0	200	5,5	-4.0	CP..09T308	MS1155	T15
E20SSCLPR09	20	25,0	13,0	250	7,1	-2.0	CP..09T308	MS1155	T15
left hand									
E08KSCLPL06A	8	11,0	6,0	122	2,4	-6.0	CP..060204	MS1939	T7
E10MSCLPL06A	10	13,0	7,0	150	3,2	-4.0	CP..060204	MS1939	T7
E12QSCLPL06	12	16,0	9,0	180	4,8	-3.0	CP..060204	MS1153	T7
E16RSCLPL09	16	20,0	11,0	200	5,5	-4.0	CP..09T308	MS1155	T15
E20SSCLPL09	20	25,0	13,0	250	7,1	-2.0	CP..09T308	MS1155	T15

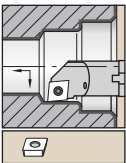

Heavy metal bar with through coolant.
See pages B92–B95 and B189–B190 for inserts.

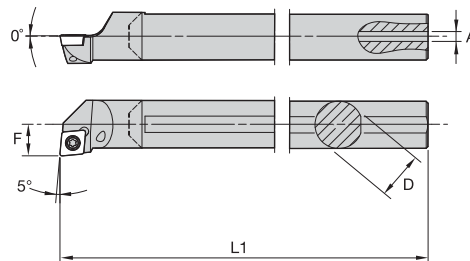

■ **L-SCLP 95°**



catalogue number	D	D min	F	L1	L2	A	γF°	gage insert	insert screw	Torx
right hand										
L08KSCLPR06	8	11,0	6,0	123	17,62	2,4	-6.0	CPMT060204..	MS1939	T7
L10MSCLPR06	10	13,0	7,0	149	21,65	3,2	-4.0	CPMT060204..	MS1939	T7
L12QSCLPR06	12	16,0	9,0	181	22,35	4,0	-3.0	CPMT060204..	MS1153	T7
L16RSCLPR09	16	20,0	11,0	203	28,57	4,0	-4.0	CPMT09T308..	MS1155	T15
L20SSCLPR09	20	25,0	13,0	251	33,61	4,0	-2.0	CPMT09T308..	MS1155	T15
left hand										
L08KSCLPL06	8	11,0	6,0	123	17,62	2,4	-6.0	CPMT060204..	MS1939	T7
L10MSCLPL06	10	13,0	7,0	149	21,65	3,2	-4.0	CPMT060204..	MS1939	T7
L12QSCLPL06	12	16,0	9,0	181	22,35	4,0	-3.0	CPMT060204..	MS1153	T7
L16RSCLPL09	16	20,0	11,0	203	28,57	4,0	-4.0	CPMT09T308..	MS1155	T15
L20SSCLPL09	20	25,0	13,0	251	33,61	4,0	-2.0	CPMT09T308..	MS1155	T15



Steel shank with through coolant.
See pages B92–B95 and B189–B190 for inserts.

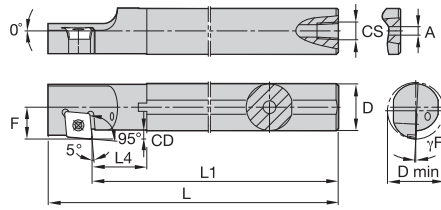

■ A-SCXP 95°



O.D./I.D. Tooling

catalogue number	D	D min	F	L1	L	L4	CD	A	CS	γF°	gage insert	insert screw	Torx
right hand													
A10KSCXPR06	10	13,0	7,0	125	136,0	15,9	2,1	3,2	—	-4.0	CP..060204	MS1153	T7
A12MSCXPR06	12	16,0	9,0	150	161,0	16,4	3,1	—	1/16-27 NPT	-3.0	CP..060204	MS1153	T7
A16RSCXPR09	16	20,0	11,0	200	218,0	17,8	3,2	—	1/8-27 NPT	-4.0	CP..09T308	MS1155	T15

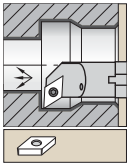

Steel shank with through coolant.
See pages B95–B98 and B191–B192 for inserts.

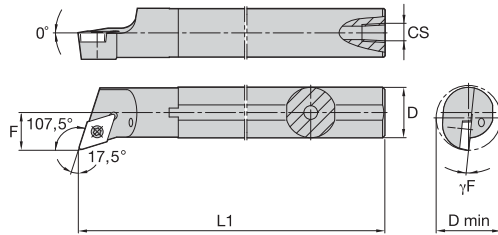

■ A-SDQC 107,5°



catalogue number	D	D min	F	L1	CS	γF°	gage insert	insert screw	Torx
right hand									
A12MSDQCR07	12	16,0	9,0	150	1/16-27 NPT	-6.0	DC..070204	MS1153	T7
A16RSDQCR07	16	20,0	11,0	200	1/8-27 NPT	-5.0	DC..070204	MS1153	T7
A20SSDQCR11	20	25,0	13,0	250	1/8-27 NPT	-5.0	DC..11T308	MS1155	T15
A25TSDQCR11	25	32,0	17,0	300	1/4-18 NPT	-4.0	DC..11T308	MS1155	T15
left hand									
A12MSDQCL07	12	16,0	9,0	150	1/16-27 NPT	-6.0	DC..070204	MS1153	T7
A16RSDQCL07	16	20,0	11,0	200	1/8-27 NPT	-5.0	DC..070204	MS1153	T7
A20SSDQCL11	20	25,0	13,0	250	1/8-27 NPT	-5.0	DC..11T308	MS1155	T15
A25TSDQCL11	25	32,0	17,0	300	1/4-18 NPT	-4.0	DC..11T308	MS1155	T15

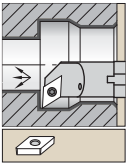

Steel shank
with through coolant.

See pages B98–B100 and
B192–B194 for inserts.

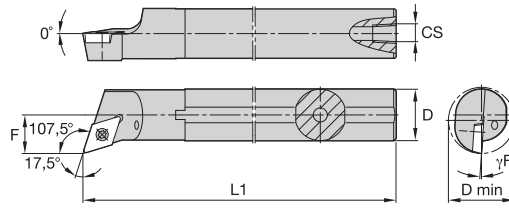

■ A-SDQP 107,5°



catalogue number	D	D min	F	L1	CS	γF°	gage insert	insert screw	Torx
right hand									
A12MSDQPR07	12	16,0	9,0	150	1/16-27 NPT	-2.0	DP..070204	MS1153	T7
A16RSDQPR07	16	20,0	11,0	200	1/8-27 NPT	0.0	DP..070204	MS1153	T7
A20SSDQPR11	20	25,0	13,0	250	1/8-27 NPT	-2.0	DP..11T308	MS1155	T15
A25TSDQPR11	25	32,0	17,0	300	1/4-18 NPT	0.0	DP..11T308	MS1155	T15
left hand									
A12MSDQPL07	12	16,0	9,0	150	1/16-27 NPT	-2.0	DP..070204	MS1153	T7
A16RSDQPL07	16	20,0	11,0	200	1/8-27 NPT	0.0	DP..070204	MS1153	T7
A20SSDQPL11	20	25,0	13,0	250	1/8-27 NPT	-2.0	DP..11T308	MS1155	T15
A25TSDQPL11	25	32,0	17,0	300	1/4-18 NPT	0.0	DP..11T308	MS1155	T15

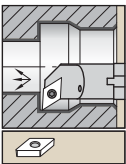

Steel shank
with through coolant.

See pages B95–B98 and
B191–B192 for inserts.

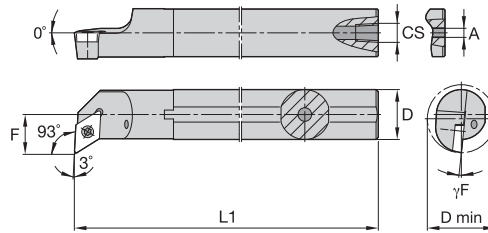

■ A-SDUC 93°



catalogue number	D	D min	F	L1	A	CS	γF°	gage insert	shim	shim screw	hex (mm)	insert screw	Torx
right hand													
A10KSDUCR07	10	13,0	7,0	125	3,2	—	-7.0	DC..070204	—	—	—	MS1153	T7
A12MSDUCR07	12	16,0	9,0	150	—	1/16-27 NPT	-4.0	DC..070204	—	—	—	MS1153	T7
A16RSDUCR07	16	20,0	11,0	200	—	1/8-27 NPT	-4.0	DC..070204	—	—	—	MS1153	T7
A16RSDUCR11	16	20,0	11,0	200	—	1/8-27 NPT	-6.0	DC..11T308	—	—	—	MS1155	T15
A20SSDUCR11	20	25,0	13,0	250	—	1/8-27 NPT	-5.0	DC..11T308	—	—	—	MS1155	T15
A25TSDUCR11	25	32,0	17,0	300	—	1/4-18 NPT	-4.0	DC..11T308	—	—	—	MS1155	T15
A32TSDUCR15	32	40,0	22,0	300	—	1/4-18 NPT	-7.0	DC..150408	SKDP453	SRS4	4 mm	MS1158	T15
left hand													
A10KSDUCL07	10	13,0	7,0	125	3,2	—	-7.0	DC..070204	—	—	—	MS1153	T7
A12MSDUCL07	12	16,0	9,0	150	—	1/16-27 NPT	-4.0	DC..070204	—	—	—	MS1153	T7
A16RSDUCL07	16	20,0	11,0	200	—	1/8-27 NPT	-4.0	DC..070204	—	—	—	MS1153	T7
A16RSDUCL11	16	20,0	11,0	200	—	1/8-27 NPT	-6.0	DC..11T308	—	—	—	MS1155	T15
A20SSDUCL11	20	25,0	13,0	250	—	1/8-27 NPT	-5.0	DC..11T308	—	—	—	MS1155	T15
A25TSDUCL11	25	32,0	17,0	300	—	1/4-18 NPT	-4.0	DC..11T308	—	—	—	MS1155	T15
A32TSDUCL15	32	40,0	22,0	300	—	1/4-18 NPT	-7.0	DC..150408	SKDP453	SRS4	4 mm	MS1158	T15

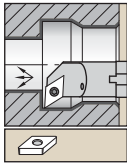

Steel shank
with through coolant.

See pages B98–B100 and
B192–B194 for inserts.

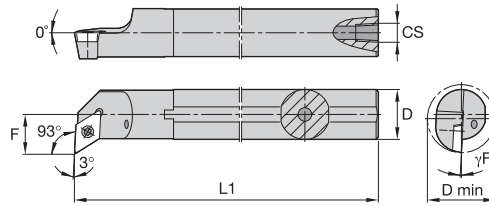

■ A-SDUP 93°



O.D./I.D. Tooling

catalogue number	D	D min	F	L1	CS	γF°	gage insert	insert screw	Torx
right hand									
A12MSDUPR07	12	16,0	9,0	150	1/16-27 NPT	-2.0	DP..070204	MS1153	T7
A16RSDUPR07	16	20,0	11,0	200	1/8-27 NPT	0.0	DP..070204	MS1153	T7
A20SSDUPR11	20	25,0	13,0	250	1/8-27 NPT	-2.0	DP..11T308	MS1155	T15
A25TSDUPR11	25	32,0	17,0	300	1/4-18 NPT	0.0	DP..11T308	MS1155	T15
left hand									
A12MSDUPL07	12	16,0	9,0	150	1/16-27 NPT	-2.0	DP..070204	MS1153	T7
A16RSDUPL07	16	20,0	11,0	200	1/8-27 NPT	0.0	DP..070204	MS1153	T7
A20SSDUPL11	20	25,0	13,0	250	1/8-27 NPT	-2.0	DP..11T308	MS1155	T15
A25TSDUPL11	25	32,0	17,0	300	1/4-18 NPT	0.0	DP..11T308	MS1155	T15

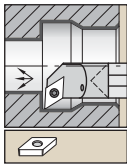

Carbide shank
with through coolant.

See pages B98–B100 and
B192–B194 for inserts.

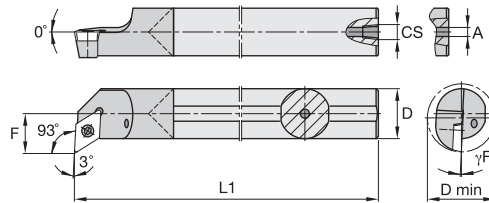

■ E-SDUP 93°



catalogue number	D	D min	F	L1	A	γF°	gage insert	insert screw	Torx
right hand									
E12QSDUPR07	12	16,0	9,0	180	4,8	-2.0	DP..070204	MS1153	T7
E16RSDUPR07	16	20,0	11,0	200	5,5	0.0	DP..070204	MS1153	T7
E20SSDUPR11	20	25,0	13,0	250	7,1	-2.0	DP..11T308	MS1155	T15
left hand									
E12QSDUPL07	12	16,0	9,0	180	4,8	-2.0	DP..070204	MS1153	T7
E16RSDUPL07	16	20,0	11,0	200	5,5	0.0	DP..070204	MS1153	T7
E20SSDUPL11	20	25,0	13,0	250	7,1	-2.0	DP..11T308	MS1155	T15

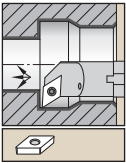

Heavy metal bar with through coolant.

See pages B98–B100 and B192–B194 for inserts.

■ L-SDUP 93°

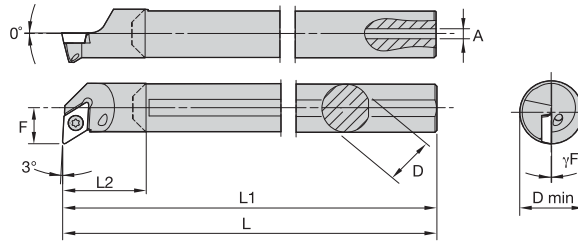

catalogue number	D	D min	F	L1	L	L2	A	γF°	gage insert	insert screw	Torx
right hand											
L12QSDUPR07	12	16,0	9,0	181	181,170	22,4	4,0	-2,0	DP..070204..	MS1153	T7
L16RSDUPR07	16	20,0	11,0	199	199,410	25,4	4,0	0,0	DP..070204..	MS1153	T7
L20SSDUPR11	20	25,0	13,0	251	251,450	33,6	4,0	-2,0	DP..11T308..	MS1155	T15
left hand											
L12QSDUPL07	12	16,0	9,0	181	181,170	22,4	4,0	-2,0	DP..070204..	MS1153	T7
L16RSDUPL07	16	20,0	11,0	199	199,410	25,4	4,0	0,0	DP..070204..	MS1153	T7
L20SSDUPL11	20	25,0	13,0	251	251,450	33,6	4,0	-2,0	DP..11T308..	MS1155	T15

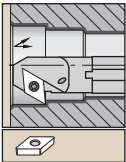

Carbide shank with through coolant.

See pages B98–B100 and B192–B194 for inserts.

■ A-SDXP 95°

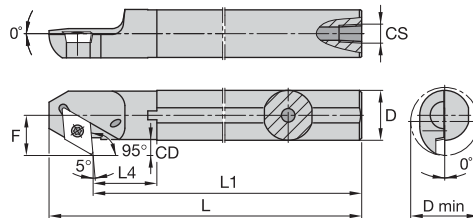

catalogue number	D	D min	F	L1	L	L4	CD	CS	gage insert	insert screw	Torx
right hand											
A12MSDXPR07	12	16,0	9,0	150	162,0	17,07	3,09	1/16-27 NPT	DP..070204	MS1153	T7
A16RSDXPR07	16	20,0	11,0	200	212,0	18,15	3,20	1/8-27 NPT	DP..070204	MS1153	T7
A20SSDXPR11	20	25,0	13,0	250	270,0	50,80	4,31	1/8-27 NPT	DP..11T308	MS1155	T15
left hand											
A12MSDXPL07	12	16,0	9,0	150	162,0	17,07	3,09	1/16-27 NPT	DP..070204	MS1153	T7
A16RSDXPL07	16	20,0	11,0	200	212,0	18,15	3,20	1/8-27 NPT	DP..070204	MS1153	T7
A20SSDXPL11	20	25,0	13,0	250	270,0	50,80	4,31	1/8-27 NPT	DP..11T308	MS1155	T15

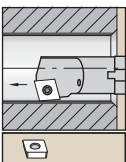

Steel shank with through coolants.

See pages B103–B104 for inserts.

■ A-SSKC 75°

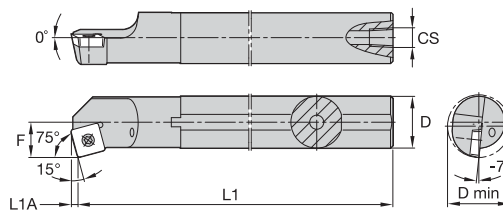

catalogue number	D	D min	F	L1	L1A	CS	gage insert	insert screw	Torx
right hand									
A16RSSKCR09	16	20,0	11,0	200	2,2	1/8-27 NPT	SC..09T308	MS1155	T15

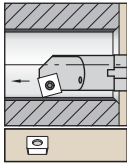

Steel shank with through coolant.

See pages B104–B106 for inserts.

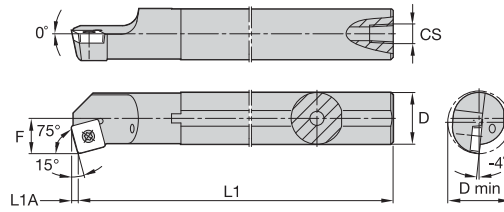

■ A-SSKP 75°

catalogue number	D	D min	F	L1	L1A	CS	gage insert	insert screw	Torx
right hand A20SSSKPR09	20	25,0	13,0	250	2,2	1/8-27 NPT	SP..09T308	MS1155	T15

O.D./I.D. Tooling

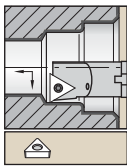

Steel shank with through coolant.

See pages B106–B108 for inserts.

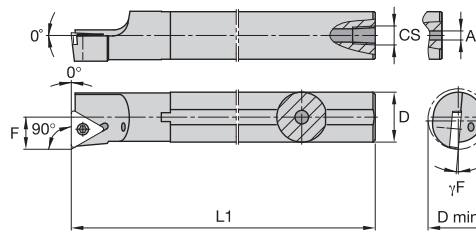

■ A-STFC 90°

catalogue number	D	D min	F	L1	A	CS	γF°	gage insert	shim	shim screw	hex (mm)	insert screw	Torx
right hand A10KSTFCR11	10	13,0	7,0	125	3,2	—	-7.0	TC..110204	—	—	—	MS1153	T7
A12MSTFCR11	12	16,0	9,0	150	—	1/16-27 NPT	-6.0	TC..110204	—	—	—	MS1153	T7
A32TSTFCR16	32	40,0	22,0	300	—	1/4-18 NPT	-2.0	TC..16T308	SKTP343	SRS3	3.5 mm	MS1156	T15
left hand A10KSTFCL11	10	13,0	7,0	125	3,2	—	-7.0	TC..110204	—	—	—	MS1153	T7
A12MSTFCL11	12	16,0	9,0	150	—	1/16-27 NPT	-6.0	TC..110204	—	—	—	MS1153	T7

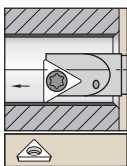

Steel shank with through coolant.

See pages B104 and B195 for inserts.

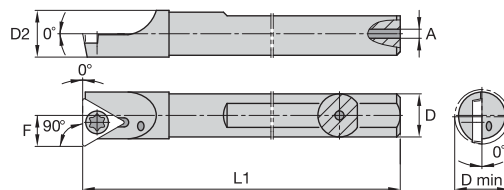

■ A-STFD 90°

catalogue number	D	D min	D2	F	L1	A	gage insert	insert screw	Torx
right hand A06HSTFDR07	6	7,1	6,2	3,7	100	1,0	TD..07T1202	FC11	T7
A08HSTFDR07	8	9,2	8,2	4,8	100	2,0	TD..07T1202	FC14	T7
left hand A12MSTFDL11	12	13,2	12,2	6,8	150	3,0	TP..110202	QC26	T9

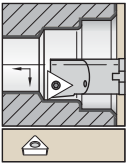

Steel shank
with through coolant.

See pages B109–B112 and
B195–B196 for inserts.

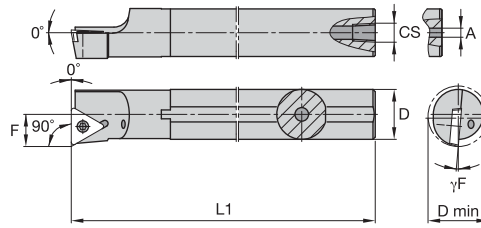

■ A-STFP 90°



catalogue number	D	D min	F	L1	A	CS	γF°	gage insert	shim	shim screw	hex (mm)	insert screw	Torx
right hand													
A08JSTFPR09	8	11,0	6,0	110	2,4	—	-8.0	TP..090204	—	—	—	MS1933	T7
A10KSTFPR11	10	13,0	7,0	125	3,2	—	-4.0	TP..110204	—	—	—	MS1153	T7
A12MSTFPR11	12	16,0	9,0	150	4,0	1/16-27 NPT	-2.0	TP..110204	—	—	—	MS1153	T7
A16RSTFPR11	16	20,0	11,0	200	—	1/16-27 NPT	0.0	TP..110204	—	—	—	MS1153	T7
A20SSTFPR16	20	25,0	13,0	250	—	1/8-27 NPT	-2.0	TP..16T308	—	—	—	MS1155	T15
A25STFPR16	25	32,0	17,0	300	—	1/4-18 NPT	0.0	TP..16T308	—	—	—	MS1155	T15
A32TSTFPR16	32	40,0	22,0	300	—	1/4-18 NPT	-2.0	TP..16T308	SKTP343	SRS3	3.5 mm	MS1156	T15
left hand													
A08JSTFPL09	8	11,0	6,0	110	2,4	—	-8.0	TP..090204	—	—	—	MS1933	T7
A10KSTFPL11	10	13,0	7,0	125	3,2	—	-4.0	TP..110204	—	—	—	MS1153	T7
A12MSTFPL11	12	16,0	9,0	150	4,0	1/16-27 NPT	-2.0	TP..110204	—	—	—	MS1153	T7
A16RSTFPL11	16	20,0	11,0	200	—	1/16-27 NPT	0.0	TP..110204	—	—	—	MS1153	T7
A20SSTFPL16	20	25,0	13,0	250	—	1/8-27 NPT	-2.0	TP..16T308	—	—	—	MS1155	T15
A25STFPL16	25	32,0	17,0	300	—	1/4-18 NPT	0.0	TP..16T308	—	—	—	MS1155	T15

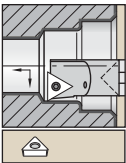

Carbide shank
with through coolant.

See pages B109–B112 and
B195–B196 for inserts.

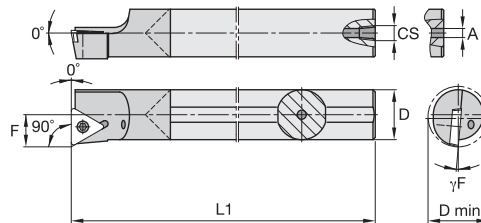

■ E-STFP 90°



catalogue number	D	D min	F	L1	A	γF°	gage insert	insert screw	Torx
right hand									
E08KSTFPR09A	8	11,0	6,0	125	2,4	-6.0	TP..090204	MS1933	T7
E10MSTFPR11A	10	13,0	7,0	150	3,2	-4.0	TP..110204	MS1153	T7
E12QSTFPR11	12	16,0	9,0	180	4,8	-2.0	TP..110204	MS1153	T7
E16RSTFPR11	16	20,0	11,0	200	5,5	0.0	TP..110204	MS1153	T7
E20SSTFPR16	20	25,0	13,0	250	7,1	-2.0	TP..16T308	MS1155	T15
left hand									
E08KSTFPL09A	8	11,0	6,0	125	2,4	-6.0	TP..090204	MS1933	T7
E10MSTFPL11A	10	13,0	7,0	150	3,2	-4.0	TP..110204	MS1153	T7
E12QSTFPL11	12	16,0	9,0	180	4,8	-2.0	TP..110204	MS1153	T7
E16RSTFPL11	16	20,0	11,0	200	5,5	0.0	TP..110204	MS1153	T7
E20SSTFPL16	20	25,0	13,0	250	7,1	-2.0	TP..16T308	MS1155	T15

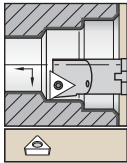

Heavy-metal bar with through coolant.

See pages B109–B112 and B195–B196 for inserts.

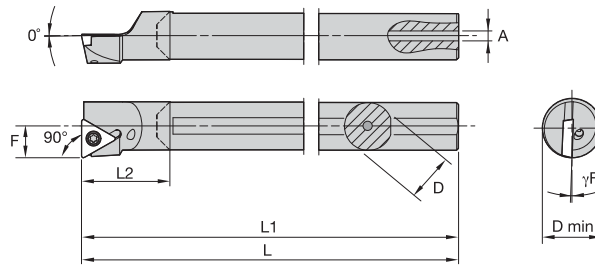

■ **L-STFP 90°**



O.D./I.D. Tooling

catalogue number	D	D min	F	L1	L2	A	γF°	gage insert	insert screw	Torx
right hand										
L08KSTFPR09	8	11,0	6,0	125	19,1	2,4	-6.0	TP..090204..	MS1933	T7
L10MSTFPR11	10	13,0	7,0	151	23,7	3,2	-4.0	TP..110204..	MS1153	T7
L12QSTFPR11	12	16,0	9,0	183	24,4	4,0	-2.0	TP..110204..	MS1153	T7
L16RSTFPR11	16	20,0	11,0	201	27,4	4,0	0.0	TP..110204..	MS1153	T7
L20SSTFPR16	20	25,0	13,0	251	33,6	4,0	-2.0	TP..16T308..	MS1155	T15
left hand										
L08KSTFPL09	8	11,0	6,0	125	19,1	2,4	-6.0	TP..090204..	MS1933	T7
L10MSTFPL11	10	13,0	7,0	151	23,7	3,2	-4.0	TP..110204..	MS1153	T7
L12QSTFPL11	12	16,0	9,0	183	24,4	4,0	-2.0	TP..110204..	MS1153	T7
L16RSTFPL11	16	20,0	11,0	201	27,4	4,0	0.0	TP..110204..	MS1153	T7
L20SSTFPL16	20	25,0	13,0	251	33,6	4,0	-2.0	TP..16T308..	MS1155	T15

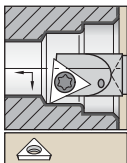

Steel shank with through coolant.

See pages B109 and B195 for inserts.

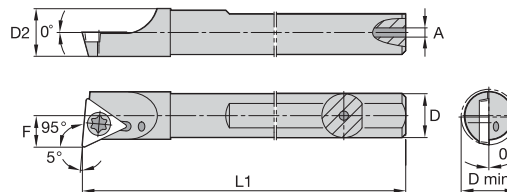

■ **A-STLD 95°**



catalogue number	D	D min	D2	F	L1	A	gage insert	insert screw	Torx	
right hand										
A06HSTLDR07	6	7,1	6,2	3,7	100	1,0	TD..07T1202	FC11	T7	
A08HSTLDR07	8	9,2	8,2	4,8	100	2,0	TD..07T1202	FC14	T7	
A20RSTLDR6P	20	21,3	20,2	10,9	200	7,2	TD..160308	SC30	T10	

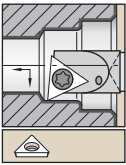

Carbide shank with through coolant.
See pages B109 and B195 for inserts.

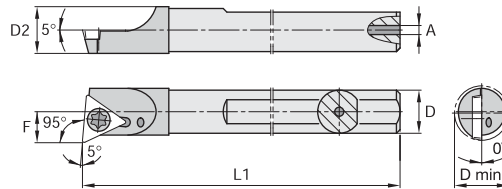

■ E-STLD 95°



catalogue number	D	D min	D2	F	L1	A	gage insert	insert screw	Torx
right hand									
E06MSTLDR07	6	7,1	6,2	3,7	150	1,2	TD..07T1202	FC11	T7
E08MSTLDR07	8	9,2	8,2	4,8	150	2,4	TD..07T1202	FC14	T7
left hand									
E06MSTLDL07	6	7,1	6,2	3,7	150	1,2	TD..07T1202	FC11	T7
E08MSTLDL07	8	9,2	8,2	4,8	150	2,4	TD..07T1202	FC14	T7

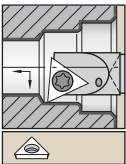

Necked steel shank with through coolant.
See pages B109 and B195 for inserts.

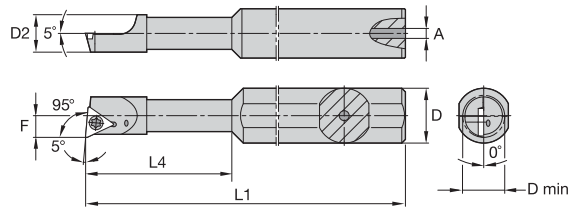

■ A-STLD 95°



catalogue number	D	D min	D2	F	L1	L4	A	gage insert	insert screw	Torx
right hand										
A0512XSTLDR0725	12	7,0	5,16	3,2	76	25,4	1,0	TD..07T1202	FC11	T7
A0612XSTLDR0731	12	7,5	6,58	4,0	76	31,8	1,0	TD..07T1202	FC14	T7
left hand										
A0616HSTLDR0731	16	7,5	6,58	4,0	100	31,8	1,0	TD..07T1202	FC14	T7

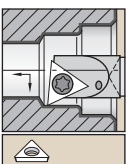

Necked carbide shank with through coolant.
See pages B109 and B195 for inserts.

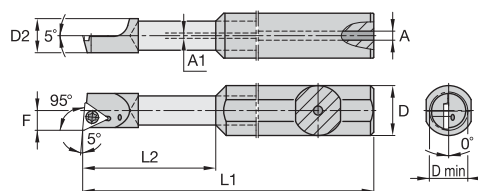

■ E-STLD 95°



catalogue number	D	D min	D2	F	L1	L2	A	A1	gage insert	insert screw	Torx
right hand											
E0612ESTLDR0731	12	7,5	6,35	4,0	70	31,7	3,18	1,2	TD..07T1202	FC14	T7
E0812XSTLDR0738	12	9,1	7,92	4,8	76	38,1	3,18	2,4	TD..07T1202	FC14	T7
E0616XSTLDR0731	16	7,5	6,35	4,0	95	31,7	3,18	1,2	TD..07T1202	FC14	T7

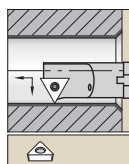

Steel shank
with through coolant.

See pages B109–B112 and
B195–B196 for inserts.

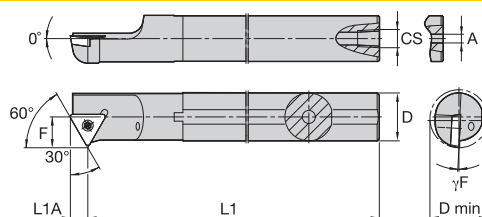

■ A-STWP 60°



O.D./I.D. Tooling

catalogue number	D	D min	F	L1	L1A	A	CS	γF°	gage insert	insert screw	Torx
right hand											
A10KSTWPR11	10	13,0	7,0	125	5,0	3,2	—	-4.0	TP..110204	MS1153	T7
A12MSTWPR11	12	16,0	9,0	150	5,0	—	1/16-27 NPT	-2.0	TP..110204	MS1153	T7
A16RSTWPR11	16	20,0	11,0	200	5,0	—	1/8-27 NPT	-2.0	TP..110204	MS1153	T7
left hand											
A10KSTWPL11	10	13,0	7,0	125	5,0	3,2	—	-4.0	TP..110204	MS1153	T7
A12MSTWPL11	12	16,0	9,0	150	5,0	—	1/16-27 NPT	-2.0	TP..110204	MS1153	T7
A16RSTWPL11	16	20,0	11,0	200	5,0	—	1/8-27 NPT	-2.0	TP..110204	MS1153	T7

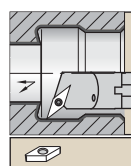

Steel shank
with through coolant.

See pages B113–B114 and
B196–B197 for inserts.

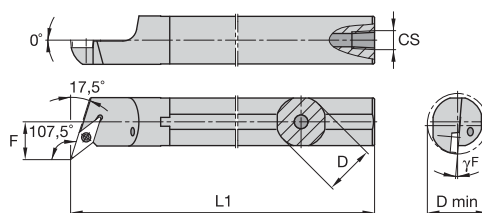

■ A-SVQB 107,5°



catalogue number	D	D min	F	L1	CS	γF°	gage insert	insert screw	Torx
right hand									
A16RSVQBR11	16	20,0	11,0	200	1/8-27 NPT	-7.0	VB..110304	MS1153	T7
A20SSVQBR11	20	25,0	13,0	250	1/8-27 NPT	-6.0	VB..110304	MS1153	T7
A25TSVQBR16	25	32,0	17,0	300	1/4-18 NPT	-6.0	VB..160408	MS1155	T15
left hand									
A16RSVQBL11	16	20,0	11,0	200	1/8-27 NPT	-7.0	VB..110304	MS1153	T7
A20SSVQBL11	20	25,0	13,0	250	1/8-27 NPT	-6.0	VB..110304	MS1153	T7
A25TSVQBL16	25	32,0	17,0	300	1/4-18 NPT	-6.0	VB..160408	MS1155	T15

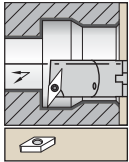

Steel shank
with through coolant.

See pages B113–B114 and
B196–B197 for inserts.

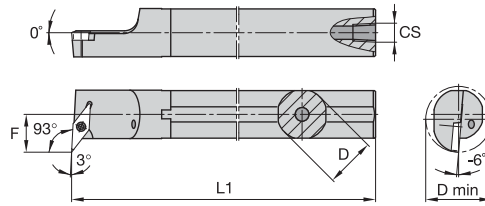

■ A-SVUB 93°



catalogue number	D	D min	F	L1	CS	gage insert	insert screw	Torx
right hand								
A20SSVUBR11	20	25,0	13,0	250	1/8-27 NPT	VB..110304	MS1153	T7
A25TSVUBR16	25	32,0	17,0	300	1/4-18 NPT	VB..160408	MS1155	T15
left hand								
A20SSVUBL11	20	25,0	13,0	250	1/8-27 NPT	VB..110304	MS1153	T7
A25TSVUBL16	25	32,0	17,0	300	1/4-18 NPT	VB..160408	MS1155	T15

O.D./I.D. Tooling

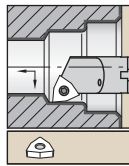

Steel shank
with through coolant.

See pages B114–B115 for inserts.

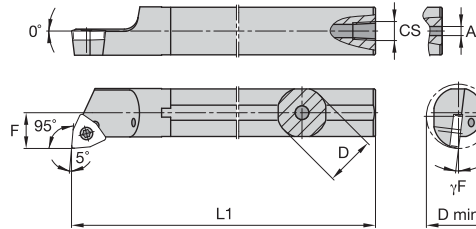

■ A-SWLC 95°



catalogue number	D	D min	F	L1	A	CS	γF°	gage insert	insert screw	Torx
right hand										
A10KSWLCR04	10	13,0	7,0	125	3,0	—	-7.0	WC..040204	MS1153	T7
A12MSWLCR04	12	16,0	9,0	150	—	1/16-27 NPT	-6.0	WC..040204	MS1153	T7
A16RSWLCR06	16	20,0	11,0	200	—	1/8-27 NPT	-7.0	WC..06T308	MS1155	T15
left hand										
A20SSWLCR06	20	25,0	13,0	250	—	1/8-27 NPT	-5.0	WC..06T308	MS1155	T15
A12MSWLCR04	12	16,0	9,0	150	—	1/16-27 NPT	-6.0	WC..040204	MS1153	T7
A16RSWLCR06	16	20,0	11,0	200	—	1/8-27 NPT	-7.0	WC..06T308	MS1155	T15

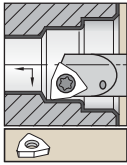

Steel shank
with through coolant.
See page B115 for inserts.

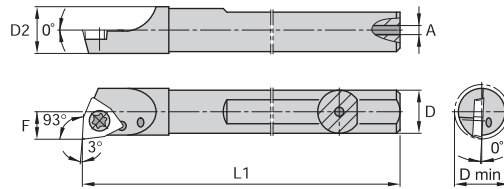

A-SWUP 93°



O.D./I.D. Tooling

catalogue number	D	D min	D2	F	L1	A	gage insert	insert screw	Torx
right hand									
A06HSWUPRS3	6	6,8	6,2	3,4	100	1,0	WP..S30102	CT11	T6
A08HSWUPRS3	8	8,8	8,2	4,4	100	2,0	WP..S30102	CT15	T6
A12MSWUPR04	12	12,8	12,2	6,6	150	3,0	WP..040202	QTM26	T6
left hand									
A06HSWUPLS3	6	6,8	6,2	3,4	100	1,0	WP..S30102	CT11	T6

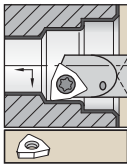

Carbide shank
with through coolant.
See page B115 for inserts.

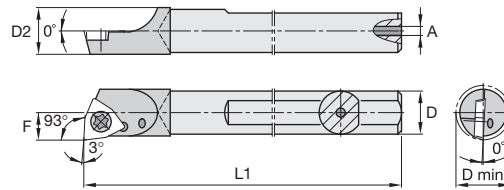

E-SWUP 93°



catalogue number	D	D min	D2	F	L1	A	gage insert	insert screw	Torx
right hand									
E06MSWUPRS3	6	6,8	6,2	3,4	150	1,2	WP..S30104	CT11	T6
E08MSWUPRS3	8	8,8	8,2	4,4	150	2,4	WP..S30104	CT15	T6
E10SSWUPR04	10	10,8	10,2	5,6	250	3,2	WP..040204	QTM20	T7
E12SSWUPR04	12	12,8	12,2	6,6	250	4,7	WP..040204	QTM26	T7
left hand									
E06MSWUPLS3	6	6,8	6,2	3,4	150	1,2	WP..S30104	CT11	T6
E08MSWUPLS3	8	8,8	8,2	4,4	150	2,4	WP..S30104	CT15	T6

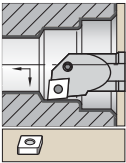

Steel shank with through coolant.
See pages B40–B49 and B174–B176 for inserts.

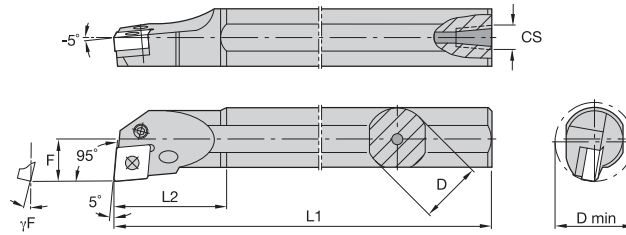

■ **A-PCLN 95°**



catalogue number	D	D min	F	L1	L2	CS	γF°	gage insert	shim	shim pin	pin	toggle lever	lever screw	Torx Plus
right hand														
A25TPCLNR12	25	32,0	17,0	300	40	1/4-18 NPT	-12.0	CN..120408	—	—	—	511.022	514.122	10 IP
A32UPCLNR12	32	40,0	22,0	350	50	1/4-18 NPT	-10.0	CN..120408	512.112	513.023	515.018	511.023	514.123	15 IP
A40VPCLNR12	40	50,0	27,0	400	55	1/4-18 NPT	-10.0	CN..120408	512.112	513.023	515.018	511.023	514.123	15 IP
A32UPCLNR16	32	50,0	22,0	350	50	1/4-18 NPT	-10.0	CN..160612	512.117	513.025	515.022	511.025	514.125	15 IP
A40VPCLNR16	40	50,0	27,0	400	55	1/4-18 NPT	-11.0	CN..160612	512.117	513.025	515.022	511.025	514.125	15 IP
left hand														
A25TPCLNL12	25	32,0	17,0	300	40	1/4-18 NPT	-12.0	CN..120408	—	—	—	511.022	514.122	10 IP
A32UPCLNL12	32	40,0	22,0	350	50	1/4-18 NPT	-10.0	CN..120408	512.112	513.023	515.018	511.023	514.123	15 IP
A40VPCLNL12	40	50,0	27,0	400	55	1/4-18 NPT	-10.0	CN..120408	512.112	513.023	515.018	511.023	514.123	15 IP
A32UPCLNL16	32	50,0	22,0	350	50	1/4-18 NPT	-10.0	CN..160612	512.117	513.025	515.022	511.025	514.125	15 IP
A40VPCLNL16	40	50,0	27,0	400	55	1/4-18 NPT	-11.0	CN..160612	512.117	513.025	515.022	511.025	514.125	15 IP

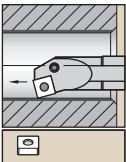

Steel shank with through coolant.
See pages B59–B66 and B178–B179 for inserts.

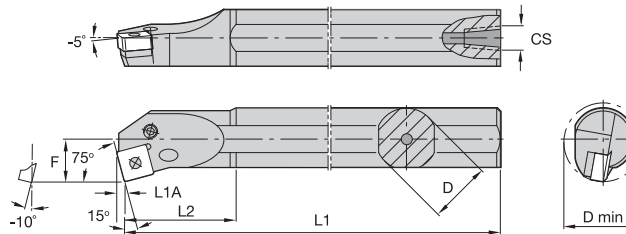

■ **A-PSKN 75°**



catalogue number	D	D min	F	L1	L2	L1A	CS	gage insert	shim	shim pin	pin	toggle lever	lever screw	Torx Plus
right hand														
A25TPSKNR12	25	30,0	17,0	300	43	3	1/4-18 NPT	SN..120408	—	—	—	511.022	514.122	10 IP
A32UPSKNR12	32	40,0	22,0	350	52	3	1/4-18 NPT	SN..120408	512.063	513.023	515.018	511.023	514.124	15 IP
A40VPSKNR12	40	48,0	27,0	400	57	3	1/4-18 NPT	SN..120408	512.063	513.023	515.018	511.023	514.124	15 IP
left hand														
A25TPSKNL12	25	30,0	17,0	300	43	3	1/4-18 NPT	SN..120408	—	—	—	511.022	514.122	10 IP
A32UPSKNL12	32	40,0	22,0	350	52	3	1/4-18 NPT	SN..120408	512.063	513.023	515.018	511.023	514.124	15 IP

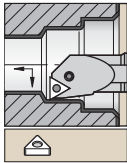

Steel shank with through coolant.
See pages B66–B73 and B179–B180 for inserts.

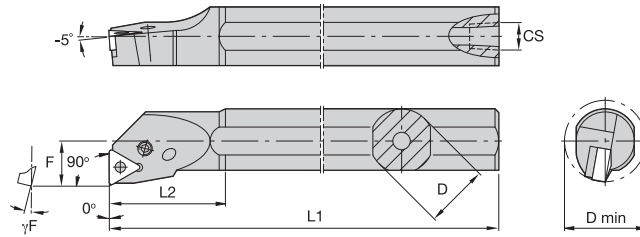

A-PTFN 90°



O.D./I.D. Tooling

catalogue number	D	D min	F	L1	L2	CS	γF°	gage insert	shim	shim pin	pin	toggle lever	lever screw	Torx Plus
right hand														
A16RPTFNR11	16	20,0	11,0	200	28	1/8-27 NPT	-14.0	TN..110304	—	—	—	511.011	514.111	8 IP
A20SPTFNR11	20	25,0	13,0	250	30	1/8-27 NPT	-12.0	TN..110304	—	—	—	511.011	514.111	8 IP
A25TPTFNR16	25	32,0	17,0	300	40	1/4-18 NPT	-12.0	TN..160408	512.013	513.018	515.018	511.018	514.118	10 IP
A32UPTFNR16	32	40,0	22,0	350	50	1/4-18 NPT	-10.0	TN..160408	512.013	513.018	515.018	511.018	514.118	10 IP
A40VPTFNR22	40	48,0	27,0	400	55	1/4-18 NPT	-10.0	TN..220408	512.023	513.023	515.018	511.023	514.123	15 IP
left hand														
A16RPTFNL11	16	20,0	11,0	200	28	1/8-27 NPT	-14.0	TN..110304	—	—	—	511.011	514.111	8 IP
A20SPTFNL11	20	25,0	13,0	250	30	1/8-27 NPT	-12.0	TN..110304	—	—	—	511.011	514.111	8 IP
A25TPTFNL16	25	32,0	17,0	300	40	1/4-18 NPT	-12.0	TN..160408	512.013	513.018	515.018	511.018	514.118	10 IP
A32UPTFNL16	32	40,0	22,0	350	50	1/4-18 NPT	-10.0	TN..160408	512.013	513.018	515.018	511.018	514.118	10 IP
A40VPTFNL22	40	48,0	27,0	400	55	1/4-18 NPT	-10.0	TN..220408	512.023	513.023	515.018	511.023	514.123	15 IP

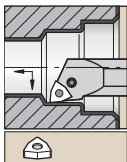

Steel shank with through coolant.
See pages B79–B83 and B181 for inserts.

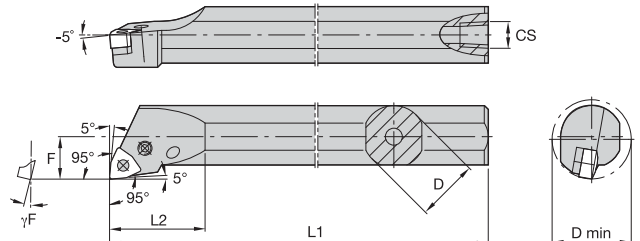

A-PWLN 95°



catalogue number	D	D min	F	L1	L2	CS	γF°	gage insert	shim	shim pin	pin	toggle lever	lever screw	Torx Plus
right hand														
A16RPWLNRO6	16	27,0	11,0	200	32	1/8-27 NPT	-12.0	WN..060404	—	—	—	511.030	514.112	8 IP
A20SPWLNRO6	20	25,0	13,0	250	32	1/8-27 NPT	-14.0	WN..060408	—	—	—	511.030	514.112	8 IP
A25RPWLNRO8	25	32,0	17,0	200	40	1/4-18 NPT	-12.0	WN..080408	512.135	513.023	515.018	511.023	514.123	15 IP
A32SPWLNRO8	32	40,0	22,0	250	50	1/4-18 NPT	-10.0	WN..080408	512.135	513.023	515.018	511.023	514.123	15 IP
A40TPWLNRO8	40	50,0	27,0	300	55	1/4-18 NPT	-8.0	WN..080408	512.135	513.023	515.018	511.023	514.123	15 IP
left hand														
A16RPWLNLO6	16	27,0	11,0	200	32	1/8-27 NPT	-12.0	WN..060404	—	—	—	511.030	514.112	8 IP
A20SPWLNLO6	20	25,0	13,0	250	32	1/8-27 NPT	-14.0	WN..060408	—	—	—	511.030	514.112	8 IP
A25RPWLNLO8	25	32,0	17,0	200	40	1/4-18 NPT	-12.0	WN..080408	512.135	513.023	515.018	511.023	514.123	15 IP
A32SPWLNLO8	32	40,0	22,0	250	50	1/4-18 NPT	-10.0	WN..080408	512.135	513.023	515.018	511.023	514.123	15 IP
A40TPWLNLO8	40	50,0	27,0	300	55	1/4-18 NPT	-8.0	WN..080408	512.135	513.023	515.018	511.023	514.123	15 IP

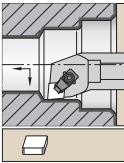

Steel shank
without through coolant.
See pages B122 and
B183 for inserts.

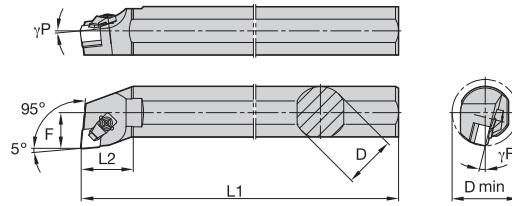

■ **S-CCLN 95° • MX**



catalogue number	D	D min	F	L1	L2	γF°	γP°	gage insert	shim	shim screw	hex (mm)	clamp assembly	hex (mm)
right hand													
S32SCCLNR12MX7	32	40,0	22,0	251	42,8	-14,0	-5,0	CN.X120708	—	—	—	551.316	4 mm
S40T-CCLNR12-MX7	40	55,0	27,0	300	40,0	-14,0	-6,0	CN.X120708	552.221	554.252	2.5 mm	551.316	4 mm
left hand													
S32SCCLNL12MX7	32	40,0	22,0	251	42,8	-14,0	-5,0	CN.X120708	—	—	—	551.316	4 mm
S40T-CCLNL12-MX7	40	55,0	27,0	300	40,0	-14,0	-6,0	CN.X120708	552.221	554.252	2.5 mm	551.316	4 mm

■ **S-CCLN 95° • MN**



catalogue number	D	D min	F	L1	L2	γF°	γP°	gage insert	shim	shim screw	hex (mm)	thrust plate	clamp assembly	hex (mm)
right hand														
S40T-CCLNR12-MN4	40	55,0	27,0	300	40,0	-14,0	-6,0	CN.N120408	552.220	554.252	2.5 mm	557.111	551.317	4 mm
S40T-CCLNR12-MN7	40	55,0	27,0	300	40,0	-14,0	-6,0	CN.N120708	552.221	554.252	2.5 mm	557.111	551.317	4 mm
left hand														
S40T-CCLNL12-MN4	40	55,0	27,0	300	40,0	-14,0	-6,0	CN.N120408	552.220	554.252	2.5 mm	557.111	551.317	4 mm
S40T-CCLNL12-MN7	40	55,0	27,0	300	40,0	-14,0	-6,0	CN.N120708	552.221	554.252	2.5 mm	557.111	551.317	4 mm

NOTE: MN clamping version is shown.

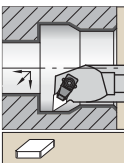

Steel shank
without through coolant.
See pages B122 and
B183 for inserts.

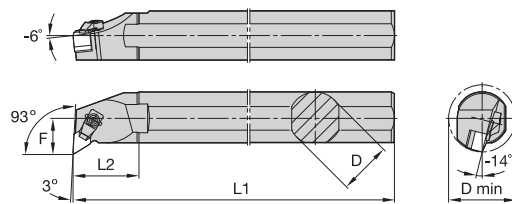

■ **S-CDUN 93° • MX**



catalogue number	D	D min	F	L1	L2	gage insert	shim	shim screw	hex (mm)	clamp assembly	hex (mm)
right hand											
S40T-CDUNR15-MX7	40	55,0	27,0	300	50,0	DN.X150708	552.228	554.252	2.5 mm	551.332	4 mm
left hand											
S40T-CDUNL15-MX7	40	55,0	27,0	300	50,0	DN.X150708	552.228	554.252	2.5 mm	551.332	4 mm

(continued)

MTS Boring Bars

-MX, -MN, and -MF for Kendex™ Negative Inserts and -MA for Kenloc™ Inserts



(S-CDUN 93° • MX continued)

■ S-CDUN 93° • MN



O.D./I.D. Tooling

catalogue number	D	D min	F	L1	L2	gage insert	shim	shim screw	hex (mm)	thrust plate	clamp assembly	hex (mm)
right hand S40T-CDUNR15-MN7	40	55,0	27,0	300	50,0	DN.N150708	552.228	554.252	2.5 mm	557.111	551.317	4 mm
left hand S40T-CDUNL15-MN7	40	55,0	27,0	300	50,0	DN.N150708	552.228	554.252	2.5 mm	557.111	551.317	4 mm

NOTE: MN clamping version is shown.
Basic holder may be ordered separately:
S40T-V. DUN R/L 15

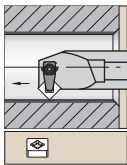

Steel shank without through coolant.

See pages B125–B126 and B184 for inserts.

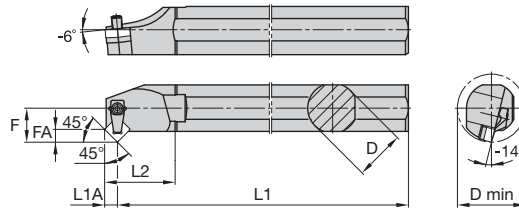

■ S-CSSN 45° • MX



catalogue number	D	D min	F	L1	L2	FA	L1A	gage insert	shim	shim screw	hex (mm)	clamp assembly	hex (mm)
right hand S40TCSSNR12MX7	40	55	27,0	300	67,0	8,23	8,50	SN.X120708	552.232	554.252	2.5 mm	551.316	4 mm
left hand S40TCSSNL12MX7	40	55	27,0	300	67,0	8,23	8,50	SN.X120708	552.232	554.252	2.5 mm	551.316	4 mm

NOTE: MX clamping version is shown.
Basic holder may be ordered separately:
S40T-V.SSN R/L 12

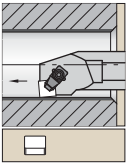

Steel shank
without through coolant.

See pages B125–B126 and
B184 for inserts.

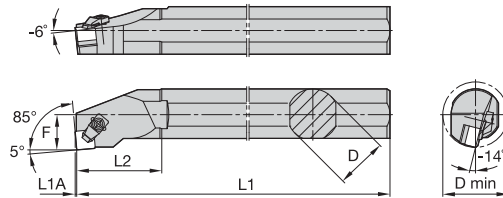
■ S-CSYN 85° • MX

catalogue number	D	D min	F	L1	L2	L1A	gage insert	shim	shim screw	hex (mm)	clamp assembly	hex (mm)
right hand												
S40T-CSYNR12-MX7	40	55,0	27,0	300	67,0	0,97	SN.X120708	552.232	554.252	2.5 mm	551.316	4 mm
left hand												
S40T-CSYNL12-MX7	40	55,0	27,0	300	67,0	0,97	SN.X120708	552.232	554.252	2.5 mm	551.316	4 mm

NOTE: MN clamping version is shown.
Basic holder may be ordered separately:
S40T-V.SYN R/L 08

■ S-CSYN 85° • MN

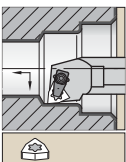

catalogue number	D	D min	F	L1	L2	L1A	gage insert	shim	shim screw	hex (mm)	thrust plate	clamp assembly	hex (mm)
right hand													
S40T-CSYNR12-MN7	40	55,0	27,0	300	67,0	0,97	SN.N120708	552.232	554.252	2.5 mm	557.111	551.317	4 mm
left hand													
S40T-CSYNL12-MN7	40	55,0	27,0	300	67,0	0,97	SN.N120708	552.232	554.252	2.5 mm	557.111	551.317	4 mm

NOTE: MN clamping version is shown.

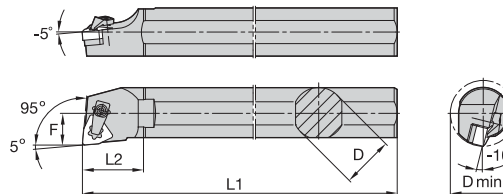

Steel shank
without through coolant.

See page B127 for inserts.

■ S-CWLN 95° • MX

catalogue number	D	D min	F	L1	L2	gage insert	shim	shim screw	hex (mm)	clamp assembly	hex (mm)
right hand											
S40TCWLN R08MX7	40	80	27,0	300	55,0	WN.X080708	552.210	554.252	2.5 mm	551.316	4 mm
left hand											
S40TCWLN L08MX7	40	80	27,0	300	55,0	WN.X080708	552.210	554.252	2.5 mm	551.316	4 mm

NOTE: Basic holder may be ordered separately:
S40T-V.WLN R/L 12

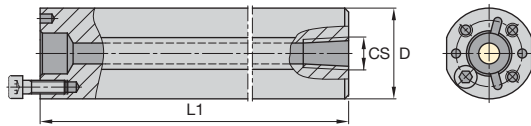

Steel shank with through coolant.

Max 4:1 overhang ratio.

■ BS

catalogue number	D	L1	CS	screw 3 required	screw	hex (mm)
BS32S	32	210	RP3/8	MS412	MS330	4 mm
BS40T	40	260	RP3/8	MS412	MS330	4 mm
BS50U	50	310	RP3/8	MS337	MS339	5 mm
BS60V	60	360	RP3/8	MS337	MS339	5 mm

O.D./I.D. Tooling

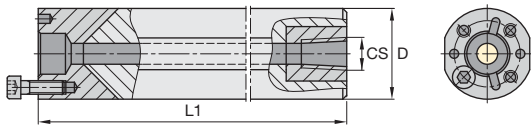

Carbide shank with through coolant.

Max 6:1 overhang ratio.

■ BC

catalogue number	D	L1	CS	screw 3 required	screw	hex (mm)
BC25T	25	260	RP1/4	MS322	MS322	3 mm
BC32U	32	310	RP3/8	MS330	MS330	4 mm
BC40V	40	360	RP3/8	MS330	MS330	4 mm
BC50W	50	410	RP3/8	MS339	MS339	5 mm

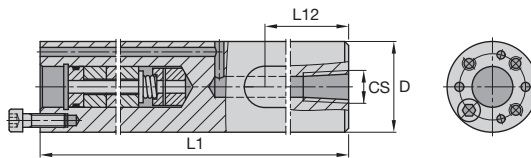

Steel shank DeVibrator with through coolant.

Max 6:1 overhang ratio.

■ BSD

catalogue number	D	L1	CS	L12	L1 min	screw 3 required	screw	hex (mm)
BSD32U	32	310	RP3/8	200	200	MS330	MS330	4 mm
BSD40V	40	360	RP3/8	248	228	MS330	MS330	4 mm
BSD50W	50	410	RP3/8	280	276	MS339	MS339	5 mm

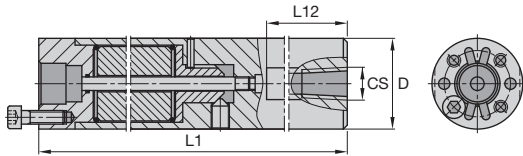

Tunable steel shank with through coolant.

■ D...TTB

catalogue number	D	L1	CS	L12	L1 min	screw 3 required	screw	hex
D25MTTB400	25	381	RP1/4	203	227	MS1499	MS319	3 mm
D32MTTB447	32	422	RP3/8	267	332	MS325	MS1130	4 mm
D40MTTB530	40	492	RP3/8	305	300	MS326	MS330	4 mm
D50MTTB700	50	670	RP3/8	470	309	MS337	MS339	5 mm

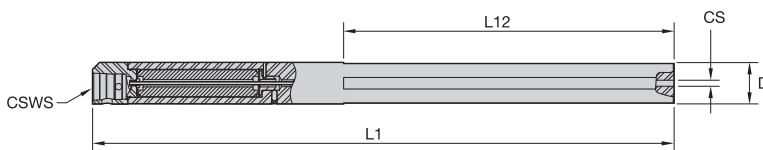

Tunable steel shank with through coolant and front end KM™ clamping unit.



■ D...TTB-KM

catalogue number	CSWS system size	D	L1	CS	L12	L1 min
D40MTTB560KM40	KM40	40	520	RP 3/8-19	305	330
D50MTTB737KM40	KM40	50	697	RP 3/8-19	470	337
D60MTTB1000KM40	KM40	60	976	RP 3/8-19	686	396
D80MTTB1120KM63	KM63	80	1060	RP 3/8-19	610	560
D100MTTB1330KM63	KM63	100	1384	RP 3/8-19	622	695

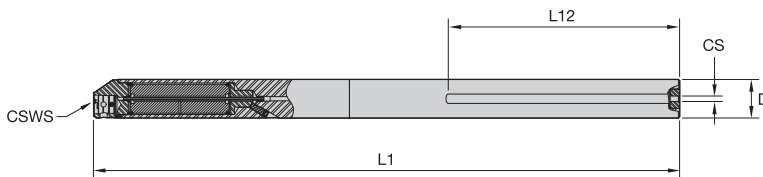

• Carbide tunable boring bar with KM Quick Change connection.



■ G-KM-TTB • Metric

order number	catalogue number	D	L1	CS	L12	CSWS system size
3954298	G50MTTB1026KM40	50	986	RP 3/8-19	300	KM40
3954299	G60MTTB1226KM40	60	1186	RP 3/8-19	381	KM40
3954300	G80MTTB1666KM63	80	1606	RP 3/8-19	480	KM63
3954301	G100MTTB2066KM63	100	1975	RP 3/8-19	600	KM63

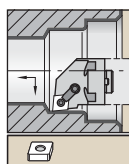

With through coolant.
See pages B40–B49 and
B174–B176 for inserts.

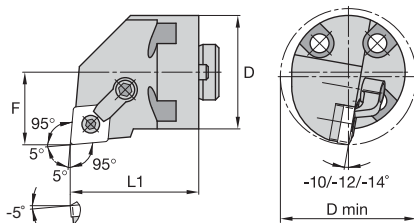

H-MCLN 95°



O.D./I.D. Tooling

catalogue number	D	F	L1	D min	gage insert	shim	lock pin	hex (mm)	clamp	clamp screw	hex (mm)
right hand											
H25MCLNR12	25	17	41	32	CN..120408	—	KLM43	2 mm	CKM7	STCM9	2.5 mm
H32MCLNR12	32	22	41	40	CN..120408	ICSN432	KLM46	2.5 mm	CKM21	STCM20	3 mm
H40MCLNR16	40	27	41	50	CN..160612	ICSN533	KLM58	3 mm	CKM12	STCM4	4 mm
H40MCLNR19	40	27	41	50	CN..190612	ICSN633	KLM68	4 mm	CKM12	STCM4	4 mm
H50MCLNR12	50	35	41	63	CN..120408	ICSN432	KLM46	2.5 mm	CKM20	STCM20	3 mm
H50MCLNR16	50	35	41	63	CN..160612	ICSN533	KLM58	3 mm	CKM12	STCM4	4 mm
H50MCLNR19	50	35	41	63	CN..190612	ICSN633	KLM68	4 mm	CKM12	STCM4	4 mm
left hand											
H25MCLNL12	25	17	41	32	CN..120408	—	KLM43	2 mm	CKM7	STCM9	2.5 mm
H32MCLNL12	32	22	41	40	CN..120408	ICSN432	KLM46	2.5 mm	CKM21	STCM20	3 mm
H40MCLNL16	40	27	41	50	CN..160612	ICSN533	KLM58	3 mm	CKM12	STCM4	4 mm
H40MCLNL19	40	27	41	50	CN..190612	ICSN633	KLM68	4 mm	CKM12	STCM4	4 mm
H50MCLNL12	50	35	41	63	CN..120408	ICSN432	KLM46	2.5 mm	CKM20	STCM20	3 mm
H50MCLNL16	50	35	41	63	CN..160612	ICSN533	KLM58	3 mm	CKM12	STCM4	4 mm
H50MCLNL19	50	35	41	63	CN..190612	ICSN633	KLM68	4 mm	CKM12	STCM4	4 mm

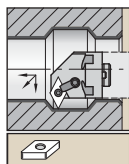

With through coolant.
See pages B50–B58 and
B176–B178 for inserts.

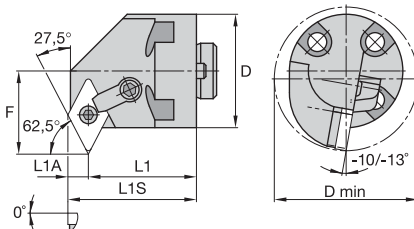

H-MDPN 62,5°



catalogue number	D	F	L1	L1A	L1S	D min	gage insert	shim	lock pin	hex (mm)	clamp	clamp screw	hex (mm)
right hand													
H25MDPNR11	25	19	37	5	41	32	DN..110408	IDSN322	KLM34L	2 mm	CKM7	STCM5	2.5 mm
H32MDPNR15	32	25	35	7	41	43	DN..150408	IDSN442	KLM46L	2.5 mm	CKM22	STCM20	3 mm
H40MDPNR15	40	28	35	7	41	50	DN..150608	IDSN432	KLM46L	2.5 mm	CKM22	STCM20	3 mm
H40MDPNR19	40	28	33	8	41	50	DN..190612	IDSN533	KLM58	3 mm	CKM12	STCM4	4 mm
H50MDPNR15	50	35	35	7	41	63	DN..150608	IDSN432	KLM46L	2.5 mm	CKM22	STCM20	3 mm
H50MDPNR19	50	35	33	8	41	63	DN..190612	IDSN533	KLM58	3 mm	CKM12	STCM4	4 mm
left hand													
H25MDPNL11	25	19	37	5	41	32	DN..110408	IDSN322	KLM34L	2 mm	CKM7	STCM5	2.5 mm
H32MDPNL15	32	25	35	7	41	43	DN..150408	IDSN442	KLM46L	2.5 mm	CKM22	STCM20	3 mm
H40MDPNL15	40	28	35	7	41	50	DN..150608	IDSN432	KLM46L	2.5 mm	CKM22	STCM20	3 mm
H40MDPNL19	40	28	33	8	41	50	DN..190612	IDSN533	KLM58	3 mm	CKM12	STCM4	4 mm
H50MDPNL15	50	35	35	7	41	63	DN..150608	IDSN432	KLM46L	2.5 mm	CKM22	STCM20	3 mm
H50MDPNL19	50	35	33	8	41	63	DN..190612	IDSN533	KLM58	3 mm	CKM12	STCM4	4 mm

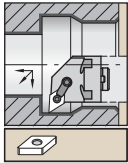

With through coolant.
 See pages B50–B58 and
 B176–B178 for inserts.

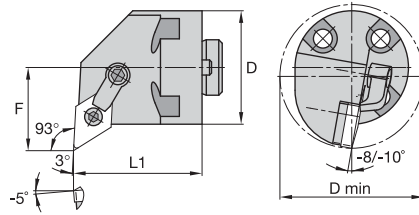

H-MDUN 93°

catalogue number	D2	F	L1	D min	gage insert	shim	lock pin	hex (mm)	clamp	clamp screw	hex (mm)
right hand											
H40MDUNR15	40	27	41	50	DN..150608	IDSN432	KLM46L	2.5 mm	CKM22	STCM20	3 mm
H50MDUNR19	50	35	41	63	DN..190612	IDSN533	KLM58	3 mm	CKM12	STCM4	4 mm
left hand											
H50MDUNL19	50	35	41	63	DN..190612	IDSN533	KLM58	3 mm	CKM12	STCM4	4 mm

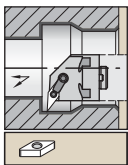
O.D./I.D. Tooling

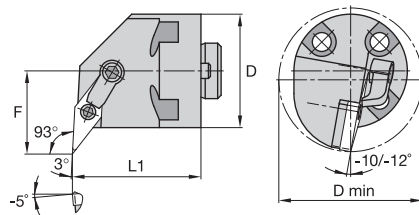

With through coolant.
 See pages B74–B78 and
 B180–B181 for inserts.

H-MVUN 93°

catalogue number	D	F	L1	D min	gage insert	shim	lock pin	hex (mm)	clamp	clamp screw	hex (mm)
right hand											
H32MVUNR16	32	25	41	43	VN..160408	IVSN322	KLM34L	2 mm	CKM23	STCM20	3 mm
H40MVUNR16	40	27	41	50	VN..160408	IVSN322	KLM34L	2 mm	CKM22	STCM20	3 mm
H50MVUNR16	50	35	41	63	VN..160408	IVSN322	KLM34L	2 mm	CKM22	STCM20	3 mm
H50MVUNR22	50	35	41	63	VN..220408	IVSN432	KLM46	2.5 mm	CKM22	STCM20	3 mm
left hand											
H32MVUNL16	32	25	41	43	VN..160408	IVSN322	KLM34L	2 mm	CKM23	STCM20	3 mm
H40MVUNL16	40	27	41	50	VN..160408	IVSN322	KLM34L	2 mm	CKM22	STCM20	3 mm
H50MVUNL16	50	35	41	63	VN..160408	IVSN322	KLM34L	2 mm	CKM22	STCM20	3 mm
H50MVUNL22	50	35	41	63	VN..220408	IVSN432	KLM46	2.5 mm	CKM22	STCM20	3 mm

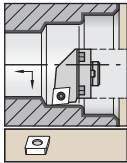

With through coolant.
See pages B88–B91 and
B187–B188 for inserts.

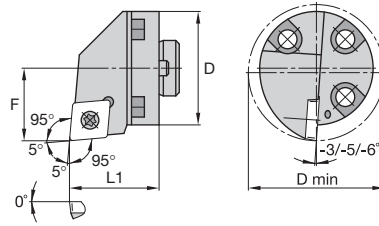

■ H-SCLC 95°



O.D./I.D. Tooling

catalogue number	D	F	L1	D min	gage insert	insert screw	Torx
right hand							
H25SCLCR09	25	17	20	32,000	CC..09T308	MS1155	T15
H25SCLCR12	25	17	25	32,000	CC..120408	MS1157	T15
H32SCLCR09	32	22	25	40,000	CC..09T308	MS1155	T15
H32SCLCR12	32	22	25	40,000	CC..120408	MS1158	T15
H40SCLCR09	40	27	41	50,000	CC..09T308	MS1156	T15
H40SCLCR12	40	27	41	50,000	CC..120408	MS1158	T15
H50SCLCR09	50	35	41	63,000	CC..09T308	MS1156	T15
H50SCLCR12	50	35	41	63,000	CC..120408	MS1158	T15
left hand							
H25SCLCL09	25	17	20	32,000	CC..09T308	MS1155	T15
H25SCLCL12	25	17	25	32,000	CC..120408	MS1157	T15
H32SCLCL09	32	22	25	40,000	CC..09T308	MS1155	T15
H32SCLCL12	32	22	25	40,000	CC..120408	MS1158	T15
H40SCLCL09	40	27	41	50,000	CC..09T308	MS1156	T15
H40SCLCL12	40	27	41	50,000	CC..120408	MS1158	T15
H50SCLCL09	50	35	41	63,000	CC..09T308	MS1156	T15
H50SCLCL12	50	35	41	63,000	CC..120408	MS1158	T15

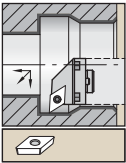

With through coolant.
See pages B95–B98 and
B191–B192 for inserts.

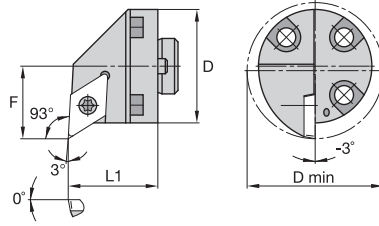

■ **H-SDUC 93°**



catalogue number	D	F	L1	D min	gage insert	insert screw	Torx
right hand							
H25SDUCR11	25	17	20	32	DC..11T308	MS1155	T15
H32SDUCR11	32	22	25	40	DC..11T308	MS1155	T15
H40SDUCR11	40	27	41	50	DC..11T308	MS1156	T15
H50SDUCR11	50	35	41	63	DC..11T308	MS1156	T15
left hand							
H25SDUCL11	25	17	20	32	DC..11T308	MS1155	T15
H32SDUCL11	32	22	25	40	DC..11T308	MS1155	T15
H40SDUCL11	40	27	41	50	DC..11T308	MS1156	T15
H50SDUCL11	50	35	41	63	DC..11T308	MS1156	T15

O.D./I.D. Tooling

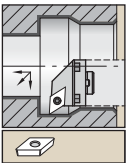

With through coolant.
See pages B113–B114 and
B196–B197 for inserts.

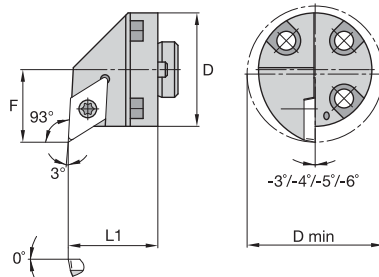

■ **H-SVUB 93°**



catalogue number	D	F	L1	D min	gage insert	insert screw	Torx
right hand							
H25SVUBR11	25	17	25	32	VB..110304	MS1153	T7
H32SVUBR11	32	22	25	40	VB..110304	MS1153	T7
H32SVUBR16	32	22	25	40	VB..160408	MS1156	T15
H40SVUBR16	40	27	41	50	VB..160408	MS1156	T15
H50SVUBR16	50	35	41	63	VB..160408	MS1156	T15
left hand							
H25SVUBL11	25	17	25	32	VB..110304	MS1153	T7
H32SVUBL11	32	22	25	40	VB..110304	MS1153	T7
H32SVUBL16	32	22	25	40	VB..160408	MS1156	T15
H40SVUBL16	40	27	41	50	VB..160408	MS1156	T15
H50SVUBL16	50	35	41	63	VB..160408	MS1156	T15

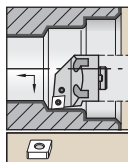

With through coolant.
See pages B40–B49 and
B174–B176 for inserts.

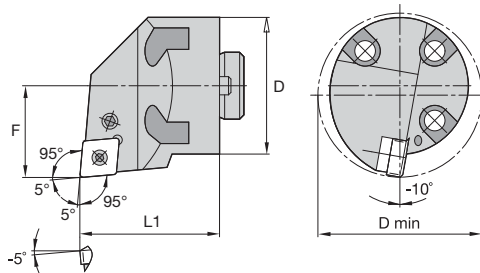

H-PCLN 95°

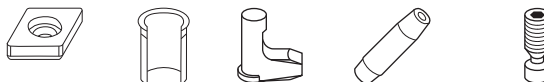

O.D./I.D. Tooling

catalogue number	D	F	L1	D min	gage insert	shim	shim pin	lever	pin punch	lever lock screw	Torx Plus
right hand											
H32PCLNR12	32	22	41	40	CN..120408	512.112	513.023	511.023	515.018	514.123	15 IP
H40PCLNR12	40	27	41	50	CN..120408	512.112	513.023	511.023	515.018	514.123	15 IP
H50PCLNR12	50	35	41	63	CN..120408	512.112	513.023	511.023	515.018	514.123	15 IP
left hand											
H32PCLNL12	32	22	41	40	CN..120408	512.112	513.023	511.023	515.018	514.123	15 IP
H40PCLNL12	40	27	41	50	CN..120408	512.112	513.023	511.023	515.018	514.123	15 IP
H50PCLNL12	50	35	41	63	CN..120408	512.112	513.023	511.023	515.018	514.123	15 IP

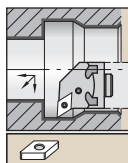

With through coolant.
See pages B50–B58 and
B176–B178 for inserts.

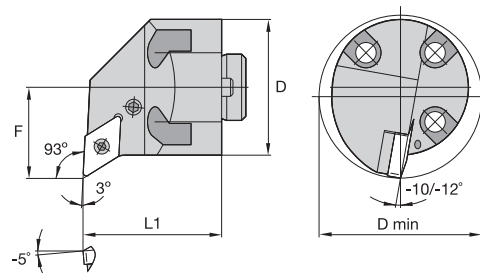

H-PDUN 93°



catalogue number	D	F	L1	D min	gage insert	shim	shim pin	pin punch	toggle lever	lever lock screw	Torx Plus
right hand											
H32PDUNR15	32	25	41	43	DN..150608	512.153	513.023	515.018	511.024	514.128	15 IP
H40PDUNR15	40	27	41	50	DN..150608	512.153	513.023	515.018	511.024	514.128	15 IP
H50PDUNR15	50	35	41	63	DN..150608	512.153	513.023	515.018	511.024	514.128	15 IP
left hand											
H32PDUNL15	32	25	41	43	DN..150608	512.153	513.023	515.018	511.024	514.128	15 IP
H40PDUNL15	40	27	41	50	DN..150608	512.153	513.023	515.018	511.024	514.128	15 IP
H50PDUNL15	50	35	41	63	DN..150608	512.153	513.023	515.018	511.024	514.128	15 IP

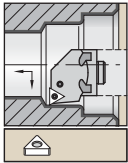

With through coolant.
See pages B66–B73 and
B179–B180 for inserts.

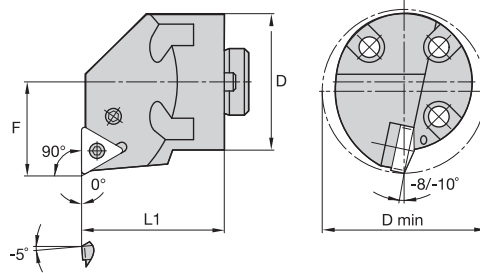

■ **H-PTFN 90°**



catalogue number	D	F	L1	D min	gage insert	shim	shim pin	pin punch	toggle lever	lever lock screw	Torx Plus
right hand											
H32PTFNR16	32	22	41	40	TN..160408	512.013	513.018	515.018	511.018	514.118	10 IP
H40PTFNR16	40	27	41	50	TN..160408	512.013	513.018	515.018	511.018	514.118	10 IP
H50PTFNR16	50	35	41	63	TN..160408	512.013	513.018	515.018	511.018	514.118	10 IP
left hand											
H32PTFNL16	32	22	41	40	TN..160408	512.013	513.018	515.018	511.018	514.118	10 IP
H40PTFNL16	40	27	41	50	TN..160408	512.013	513.018	515.018	511.018	514.118	10 IP

O.D./I.D. Tooling

Looking for a product that's not shown in this catalogue?
Check the Kennametal website!



Online product catalogue available 24/7

Visit <http://www.kennametal.com/turning/> to browse our electronic catalogue any time you're looking for Kennametal's best tooling solutions. It's fast, free, and always available. The online e-catalogue is updated weekly with products and solutions for milling, turning, drilling, and tooling systems applications.



Cartridges

Primary Application

Modern machining operations demand high-quality, high-performance toolholders that provide straightforward design and application versatility.

Standard Kennametal cartridges are ideal for turning tools with one, or several, cutting edges. A wide range of cartridge sizes and styles provide numerous combinations and application possibilities.

Features and Benefits

Kenloc™ Style (M-Clamping)

- Used for Kenloc inserts.
- Lock pin and top clamp provide rigid clamping.
- Wide variety of insert styles may be used.
- Tools may be used with or without top clamp.
- Optional hardware available for thicker inserts.
- Extreme sturdy clamping system, specially designed for interrupted cuts.
- Tool is protected by a carbide shim.

Kenlever™ Style (P-Clamping*)

- Proven superior system for holding ceramic inserts rigidly in turning and profiling operations.
- Can be used on Kendex or Kenloc inserts using optional hardware.
- Lever-type clamping system for negative indexable inserts with hole to DIN 4988 and positive round inserts more than 20mm in diameter.
- Inserts with one- and two-side chip control geometries have positive rakes from 6–18°.
- Advantages include fast insert changes and no interference with chip flow.

*NOTE: P-style available in metric sizes only.



Kendex™ Style (C-Clamping)

- Suitable for Kendex inserts.
- Chipbreaker option available for ceramic inserts.
- Wide variety of insert styles may be used.
- Top clamping system for negative and positive indexable inserts to DIN 4968.
- Universal clamping system is robust and easy to handle.
- Some height-adjustable clamps enable the use of additional chipbreakers.
- Carbide shim provides additional tool protection.

Screw-On Style (S-Clamping)

- Used for Screw-On inserts.
- Top clamping by screw.
- Screw clamping system for positive indexable inserts with countersunk hole to DIN 4967.
- Compact design using a minimum of spare parts for high reliability and cost efficiency.
- Toolholders with cutting edge heights greater than 16mm (.625") and insert ICs from 9,52mm (.375") are secured by a threaded bushing.
- Carbide shim provides additional tool protection.

How Do Catalogue Numbers Work?

Each character in our catalogue number signifies a specific trait of that product. Use the following key columns and corresponding images to easily identify which attributes apply.

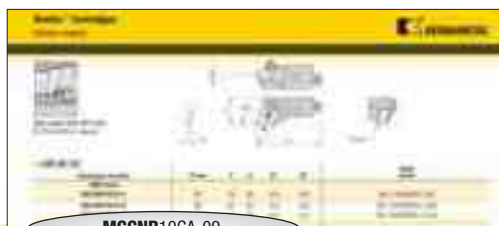

MCCNR10CA-09

O.D./I.D. Tooling

M

Insert Holding Method

C

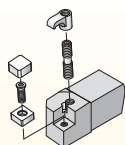

Kendex™

P

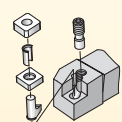

Kenlever™

M

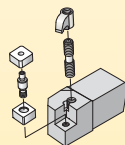

Kenloc™

S

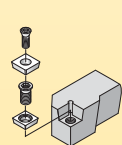

Screw-On

C

Insert Shape

C



D



R



S



T



W



C

Tool Style or Lead Angle

A



B



C



D



E



F



G



H



J



K



L



M



P



Q



R



S



U



V



Y



N

Insert Clearance Angle

N



B



C



P



D



E



F



R

Hand of Tool

R =
Right-hand
boring bar

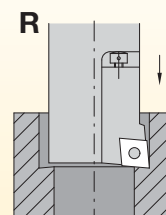

L =
Left-hand
boring bar

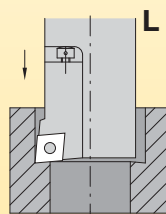

By referencing this easy-to-use guide, you can identify the correct product to meet your needs.

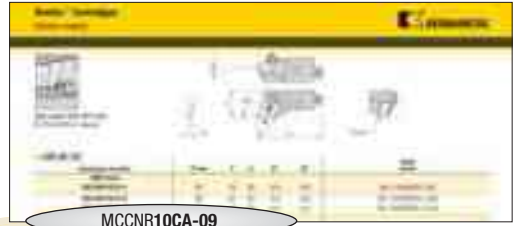

MCCNR10CA-09

10

Cartridge Size

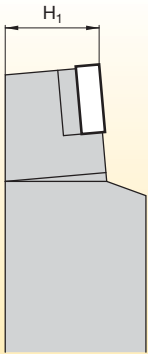

H_1 =
Cutting edge height of cartridge,
in millimetres

C

Cartridge Identification

C =
Cartridge

A

Cartridge Mounting

A =
Angular acc.
ISO 5611

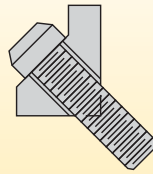

-

09

Insert Size

Cutting edge length L10

C



T



D



W



S



R



O.D./I.D. Tooling

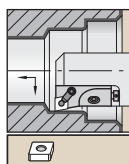

See pages B40–B49 and B174–B176 for inserts.

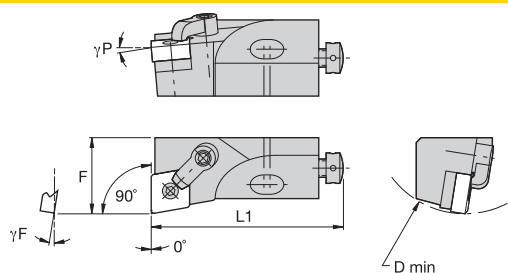

O.D./I.D. Tooling

MCFN 90°

catalogue number	D min	F	L1	γF°	γP°	gage insert
right hand						
MCFNR10CA09	40	14,0	50	-9.0	-9.0	CN..090308/CN..322
MCFNR12CA12	50	20,0	55	-9.0	-5.0	CN..120408/CN..432
MCFNR16CA12	60	25,0	63	-9.0	-5.0	CN..120408/CN..432
MCFNR20CA12	70	25,0	70	-9.0	-5.0	CN..120408/CN..432
left hand						
MCFNL10CA09	40	14,0	50	-9.0	-9.0	CN..090308/CN..322
MCFNL12CA12	50	20,0	55	-9.0	-5.0	CN..120408/CN..432
MCFNL16CA12	60	25,0	63	-9.0	-5.0	CN..120408/CN..432

Spare Parts



D min	shim	lock pin	hex	clamp	clamp screw	hex	radial adjusting screw	hex	axial adjusting screw	mounting screw	hex	washer
40	—	KLM33	2 mm	CKM36	STCM38	2 mm	KUAM28	2 mm	KUAM30	191.405	4 mm	CSWM 060 050
50	—	KLM43	2 mm	CKM34	STCM38	2 mm	KUAM22	2 mm	KUAM31	191.406	4 mm	CSWM 060 050
60	ICSN432	KLM46S	2.5 mm	CKM34	STCM9	2.5 mm	KUAM25	2.5 mm	KUAM32	191.407	5 mm	CSWM 080 050
70	ICSN432	KLM46	2.5 mm	CKM34	STCM9	2.5 mm	KUAM25	2.5 mm	KUAM32	191.407	5 mm	CSWM 080 050

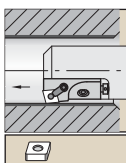

See pages B40–B49 and B174–B176 for inserts.

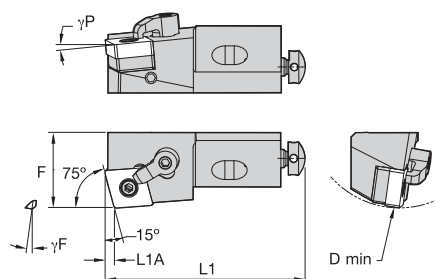

MCKN 75°

catalogue number	D min	F	L1	L1A	γF°	γP°	gage insert
right hand							
MCKNR12CA12	50	20,0	55	3	-9.0	-5.0	CN..120408/CN..432
MCKNR16CA12	60	25,0	63	3	-9.0	-5.0	CN..120408/CN..432
left hand							
MCKNL12CA12	50	20,0	55	3	-9.0	-5.0	CN..120408/CN..432
MCKNL16CA12	60	25,0	63	3	-9.0	-5.0	CN..120408/CN..432

Spare Parts



D min	shim	lock pin	hex	clamp	clamp screw	hex	radial adjusting screw	hex	axial adjusting screw	mounting screw	hex	washer
50	—	KLM43	2 mm	CKM34	STCM38	2 mm	KUAM22	2 mm	KUAM31	191.406	4 mm	CSWM 060 050
60	ICSN432	KLM46S	2.5 mm	CKM34	STCM9	2.5 mm	KUAM25	2.5 mm	KUAM32	191.407	5 mm	CSWM 080 050

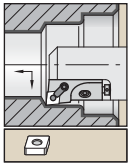

See pages B40–B49 and B174–B176 for inserts.

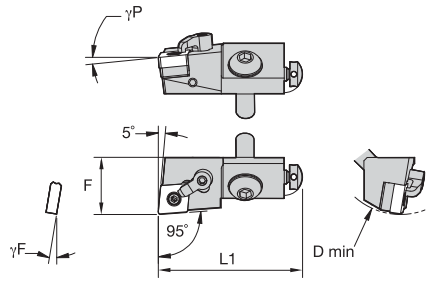

■ MCLN 95°

catalogue number	D min	F	L1	γF°	γP°	gage insert
right hand						
MCLNR12CA12	50	20,0	55	-9.0	-5.0	CN..120408/CN..432
MCLNR16CA12	60	25,0	63	-9.0	-5.0	CN..120408/CN..432
MCLNR20CA12	70	25,0	70	-9.0	-5.0	CN..120408/CN..432
MCLNR25CA12	100	32,0	100	-9.0	-5.0	CN..120408/CN..432
MCLNR25CA16	100	32,0	100	-9.0	-5.0	CN..160612/CN..543
MCLNR25CA19	100	32,0	100	-9.0	-5.0	CN..190612/CN..643
left hand						
MCLNL12CA12	50	20,0	55	-9.0	-5.0	CN..120408/CN..432
MCLNL16CA12	60	25,0	63	-9.0	-5.0	CN..120408/CN..432
MCLNL20CA12	70	25,0	70	-9.0	-5.0	CN..120408/CN..432
MCLNL25CA12	100	32,0	100	-9.0	-5.0	CN..120408/CN..432
MCLNL25CA16	100	32,0	100	-9.0	-5.0	CN..160612/CN..543
MCLNL25CA19	100	32,0	100	-9.0	-5.0	CN..190612/CN..643

O.D./I.D. Tooling

■ Spare Parts

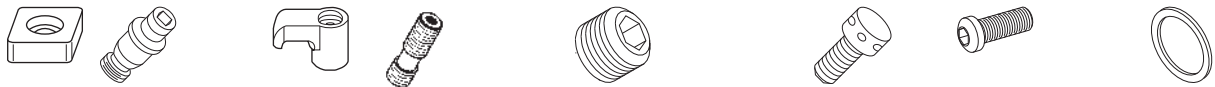

D min	shim	lock pin	hex	clamp	clamp screw	hex	radial adjusting screw	hex	axial adjusting screw	mounting screw	hex	washer
50	—	KLM43	2 mm	CKM34	STCM38	2 mm	KUAM22	2 mm	KUAM31	191.406	4 mm	CSWM 060 050
60	ICSN432	KLM46S	2.5 mm	CKM34	STCM9	2.5 mm	KUAM25	2.5 mm	KUAM32	191.407	5 mm	CSWM 080 050
70	ICSN432	KLM46	2.5 mm	CKM34	STCM9	2.5 mm	KUAM25	2.5 mm	KUAM32	191.407	5 mm	CSWM 080 050
100	ICSN432	KLM46	2.5 mm	CKM37	STCM40	2.5 mm	KUAM25	2.5 mm	KUAM32	MS364	8 mm	CSWM 100 080
100	ICSN533	KLM58	3 mm	CKM41	STCM20	3 mm	KUAM26	3 mm	KUAM32	MS364	8 mm	CSWM 100 080
100	ICSN633	KLM68	4 mm	CKM35	STCM8	4 mm	KUAM27	4 mm	KUAM32	MS364	8 mm	CSWM 100 080

NOTE: Select spare parts based off of D min and the insert size selected.

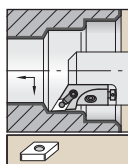

See pages B66–B73 and B179–B180 for inserts.

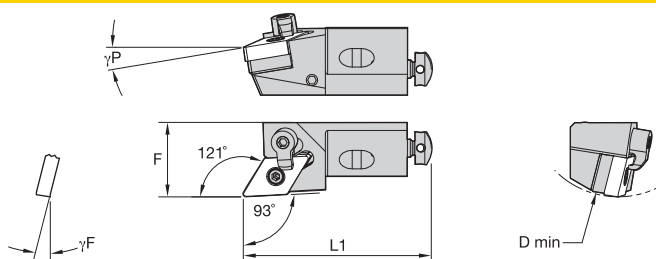

O.D./I.D. Tooling

MDJN 93°

catalogue number	D min	F	L1	γF°	γP°	gage insert
right hand						
MDJNR12CA11	50	20	55	-9.0	-9.0	DN..110408/DN..322
MDJNR16CA15	60	25	63	-9.0	-9.0	DN..150408/DN..3.532
MDJNR20CA15	70	25	70	-8.5	-8.5	DN..150408/DN..3.532
left hand						
MDJNL12CA11	50	20	55	-9.0	-9.0	DN..110408/DN..322
MDJNL16CA15	60	25	63	-9.0	-9.0	DN..150408/DN..3.532
MDJNL20CA15	70	25	70	-8.5	-8.5	DN..150408/DN..3.532

Spare Parts



D min	shim	lock pin	hex	clamp	clamp screw	hex	radial adjusting screw	hex	axial adjusting screw	mounting screw	hex	washer
50	—	KLM33L	2 mm	CKM34	STCM38	2 mm	KUAM22	2 mm	KUAM31	191.406	4 mm	CSWM 060 050
60	IDSN432	KLM46S	2.5 mm	CKM36	STCM9	2.5 mm	KUAM25	2.5 mm	KUAM32	191.407	5 mm	CSWM 080 050
70	IDSN432	KLM46	2.5 mm	CKM41	STCM40	2.5 mm	KUAM25	2.5 mm	KUAM32	191.407	5 mm	CSWM 080 050

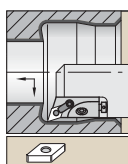

See pages B66–B73 and B179–B180 for inserts.

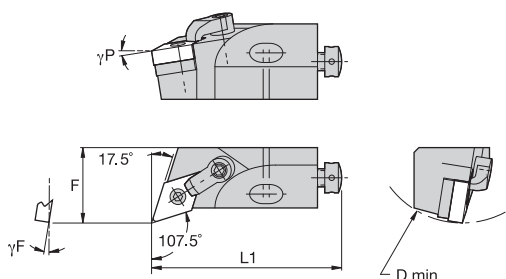

MDQN 107,5°

catalogue number	D min	F	L1	γF°	γP°	gage insert
right hand						
MDQNR16CA15	60	25,0	63	-9.0	-6.0	DN..150408/DN..3.532
MDQNR20CA15	70	25,0	70	-9.0	-8.0	DN..150408/DN..3.532
left hand						
MDQNL16CA15	60	25,0	63	-9.0	-6.0	DN..150408/DN..3.532
MDQNL20CA15	70	25,0	70	-9.0	-8.0	DN..150408/DN..3.532

Spare Parts



D min	shim	lock pin	hex	clamp	clamp screw	hex	radial adjusting screw	hex	axial adjusting screw	mounting screw	hex	washer
60	IDSN432	KLM46S	2.5 mm	CKM36	STCM9	2.5 mm	KUAM25	2.5 mm	KUAM32	191.407	5 mm	CSWM 080 050
70	IDSN432	KLM46	2.5 mm	CKM34	STCM9	2.5 mm	KUAM25	2.5 mm	KUAM32	191.407	5 mm	CSWM 080 050



See pages B59–B66 and B178–B179 for inserts.

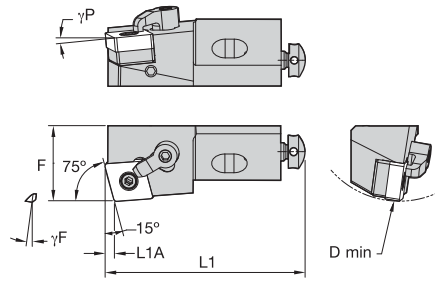

■ MSKN 75°

catalogue number	D min	F	L1	L1A	γF°	γP°	gage insert
right hand							
MSKNR10CA09	40	14,0	50	2,22	-9,0	-5,0	SN..090308/SN..322
MSKNR12CA12	50	20,0	55	3,04	-9,0	-5,0	SN..120408/SN..432
MSKNR16CA12	60	25,0	63	3,04	-9,0	-5,0	SN..120408/SN..432
MSKNR20CA15	70	25,0	70	3,74	-9,0	-5,0	SN..150612/SN..543
MSKNR25CA19	100	32,0	100	4,56	-9,0	-5,0	SN..190612/SN..543
left hand							
MSKNL10CA09	40	14,0	50	2,22	-9,0	-5,0	SN..090308/SN..322
MSKNL12CA12	50	20,0	55	3,04	-9,0	-5,0	SN..120408/SN..432
MSKNL16CA12	60	25,0	63	3,04	-9,0	-5,0	SN..120408/SN..432
MSKNL20CA15	70	25,0	70	3,74	-9,0	-5,0	SN..150612/SN..543
MSKNL25CA12	100	32,0	100	3,04	-9,0	-5,0	SN..120408/SN..432

O.D./I.D. Tooling

■ Spare Parts



D min	shim	lock pin	hex	clamp	clamp screw	hex	radial adjusting screw	hex	axial adjusting screw	mounting screw	hex	washer
40	—	KLM33	2 mm	CKM36	STCM38	2 mm	KUAM28	2 mm	KUAM30	191.405	4 mm	CSWM 060 050
50	—	KLM43	2 mm	CKM34	STCM38	2 mm	KUAM22	2 mm	KUAM31	191.406	4 mm	CSWM 060 050
60	ISSN432	KLM46S	2.5 mm	CKM34	STCM9	2.5 mm	KUAM25	2.5 mm	KUAM32	191.407	5 mm	CSWM 080 050
70	SKSN566K	KLM54	2.5 mm	CKM37	STCM40	2.5 mm	KUAM25	2.5 mm	KUAM32	191.407	5 mm	CSWM 080 050
100	ICSN432	KLM46	2.5 mm	CKM34	STCM9	2.5 mm	KUAM25	2.5 mm	KUAM32	MS364	8 mm	CSWM 100 080
100	ICSN633	KLM68	4 mm	CKM35	STCM8	4 mm	KUAM27	4 mm	KUAM32	MS364	8 mm	CSWM 100 080

NOTE: Select spare parts based off of D min and the insert size selected.



See pages B59–B66 and B178–B179 for inserts.

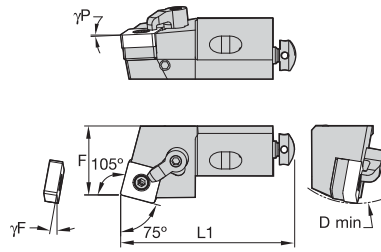

O.D./I.D. Tooling

MSRN 75°

catalogue number	D min	F	L1	γF°	γP°	gage insert
right hand						
MSRNR10CA09	40	14,0	50	-9.0	-5.0	SN..090308/SN..322
MSRNR12CA12	50	20,0	55	-9.0	-5.0	SN..120408/SN..432
MSRNR16CA12	60	25,0	63	-9.0	-5.0	SN..120408/SN..432
MSRNR20CA15	70	25,0	70	-9.0	-5.0	SN..150612/SN..543
left hand						
MSRNL10CA09	40	14,0	50	-9.0	-5.0	SN..090308/SN..322
MSRNL12CA12	50	20,0	55	-9.0	-5.0	SN..120408/SN..432
MSRNL16CA12	60	25,0	63	-9.0	-5.0	SN..120408/SN..432
MSRNL20CA15	70	25,0	70	-9.0	-5.0	SN..150612/SN..543

Spare Parts

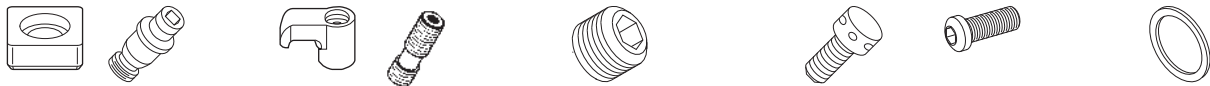

D min	shim	lock pin	hex	clamp	clamp screw	hex	radial adjusting screw	hex	axial adjusting screw	mounting screw	hex	washer
40	—	KLM33	2 mm	CKM36	STCM38	2 mm	KUAM28	2 mm	KUAM30	191.405	4 mm	CSWM 060 050
50	—	KLM43	2 mm	CKM34	STCM38	2 mm	KUAM22	2 mm	KUAM31	191.406	4 mm	CSWM 060 050
60	ISSN432	KLM46S	2.5 mm	CKM34	STCM9	2.5 mm	KUAM25	2.5 mm	KUAM32	191.407	5 mm	CSWM 080 050
70	SKSN566K	KLM54	2.5 mm	CKM37	STCM40	2.5 mm	KUAM25	2.5 mm	KUAM32	191.407	5 mm	CSWM 080 050



See pages B59–B66 and B178–B179 for inserts.

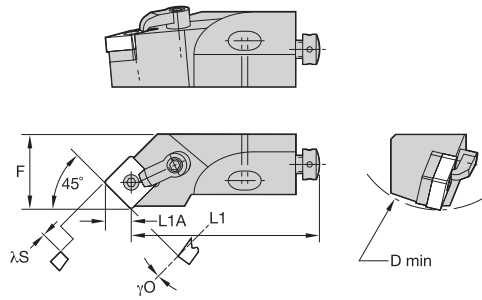

■ MSSN 45°

catalogue number	D min	F	L1	L1A	λS°	γO°	gage insert
right hand							
MSSNR10CA09	40	14,0	44	6,09	-13.0	0.0	SN..090308/SN..322
MSSNR12CA12	50	20,0	47	8,33	-13.0	0.0	SN..120408/SN..432
MSSNR16CA12	60	25,0	53	8,33	-13.0	0.0	SN..120408/SN..432
MSSNR20CA15	70	25,0	60	10,25	-13.0	0.0	SN..150612/SN..543
left hand							
MSSNL10CA09	40	14,0	44	6,09	-13.0	0.0	SN..090308/SN..322
MSSNL12CA12	50	20,0	47	8,33	-13.0	0.0	SN..120408/SN..432
MSSNL16CA12	60	25,0	53	8,33	-13.0	0.0	SN..120408/SN..432
MSSNL20CA15	70	25,0	60	10,25	-13.0	0.0	SN..150612/SN..543

■ Spare Parts



D min	shim	lock pin	hex	clamp	clamp screw	hex	radial adjusting screw	hex	axial adjusting screw	mounting screw	hex	washer
40	—	KLM33	2 mm	CKM36	STCM38	2 mm	KUAM28	2 mm	KUAM30	191.405	4 mm	CSWM 060 050
50	—	KLM43	2 mm	CKM34	STCM38	2 mm	KUAM22	2 mm	KUAM31	191.406	4 mm	CSWM 060 050
60	ISSN432	KLM46S	2.5 mm	CKM36	STCM9	2.5 mm	KUAM25	2.5 mm	KUAM32	191.407	5 mm	CSWM 080 050
70	SKSN566K	KLM54	2.5 mm	CKM37	STCM40	2.5 mm	KUAM25	2.5 mm	KUAM32	191.407	5 mm	CSWM 080 050

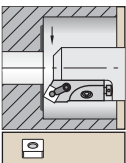

See pages B59–B66 and B178–B179 for inserts.

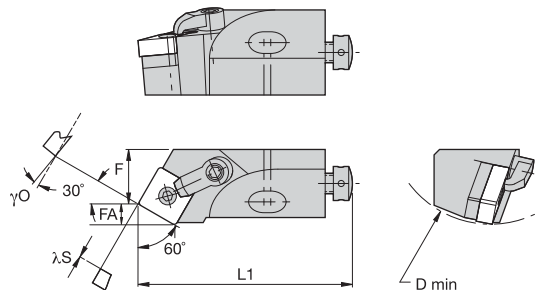

■ MSTN 60°

catalogue number	D min	F	L1	FA	λS°	γO°	gage insert
right hand							
MSTNR10CA09	40	9,0	50	13,31	-11.0	0.0	SN..090308/SN..322
MSTNR12CA12	50	13,0	55	5,86	-11.0	0.0	SN..120408/SN..432
left hand							
MSTNL10CA09	40	9,0	50	13,31	-11.0	0.0	SN..090308/SN..322
MSTNL16CA12	60	15,0	63	5,90	-11.0	0.0	SN..120408/SN..432

■ Spare Parts



D min	shim	lock pin	hex	clamp	clamp screw	hex	radial adjusting screw	hex	axial adjusting screw	mounting screw	hex	washer
40	—	KLM33	2 mm	CKM36	STCM38	2 mm	KUAM28	2 mm	KUAM30	191.405	4 mm	CSWM 060 050
50	—	KLM43	2 mm	CKM34	STCM38	2 mm	KUAM22	2 mm	KUAM31	191.406	4 mm	CSWM 060 050
60	ISSN432	KLM46S	2.5 mm	CKM34	STCM9	2.5 mm	KUAM25	2.5 mm	KUAM32	191.407	5 mm	CSWM 080 050

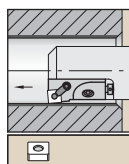

See pages B59–B66 and B178–B179 for inserts.

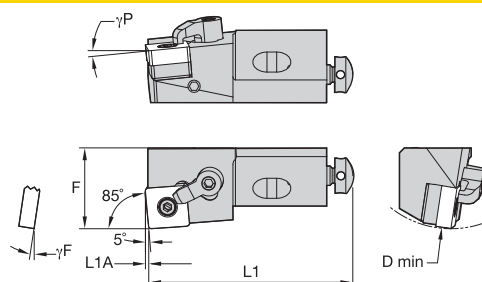

O.D./I.D. Tooling

■ **MSYN 85°**

catalogue number	D min	F	L1	L1A	γF°	γP°	gage insert
right hand							
MSYNR10CA09	40	14,0	50	0,75	-9,0	-5,0	SN..090308/SN..322
MSYNR12CA12	50	20,0	55	1,02	-9,0	-5,0	SN..120408/SN..432
MSYNR16CA12	60	25,0	63	1,02	-9,0	-5,0	SN..120408/SN..432
left hand							
MSYNL10CA09	40	14,0	50	0,75	-9,0	-5,0	SN..090308/SN..322
MSYNL12CA12	50	20,0	55	1,02	-9,0	-5,0	SN..120408/SN..432
MSYNL16CA12	60	25,0	63	1,02	-9,0	-5,0	SN..120408/SN..432
MSYNL20CA15	70	25,0	70	1,26	-9,0	-5,0	SN..150612/SN..543

■ **Spare Parts**



D min	shim	lock pin	hex	clamp	clamp screw	hex	radial adjusting screw	hex	axial adjusting screw	mounting screw	hex	washer
40	—	KLM33	2 mm	CKM36	STCM38	2 mm	KUAM28	2 mm	KUAM30	191.405	4 mm	CSWM 060 050
50	—	KLM43	2 mm	CKM34	STCM38	2 mm	KUAM22	2 mm	KUAM31	191.406	4 mm	CSWM 060 050
60	ISSN432	KLM46S	2.5 mm	CKM34	STCM9	2.5 mm	KUAM25	2.5 mm	KUAM32	191.407	5 mm	CSWM 080 050
60	ISSN432	KLM46S	2.5 mm	CKM36	STCM9	2.5 mm	KUAM25	2.5 mm	KUAM32	191.407	5 mm	CSWM 080 050
70	SKSN566K	KLM54	2.5 mm	CKM37	STCM40	2.5 mm	KUAM25	2.5 mm	KUAM33	191.407	6 mm	CSWM 080 050
100	ISSN633	KLM68	4 mm	CKM34	STCM8	4 mm	KUAM27	4 mm	KUAM33	MS364	8 mm	CSWM 100 080

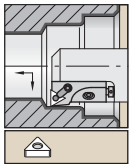

See pages B66–B73 and B179–B180 for inserts.

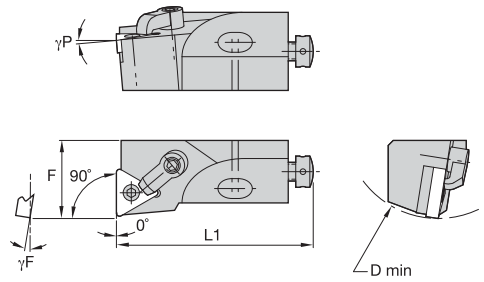

■ MTFN 90°

catalogue number	D min	F	L1	γF°	γP°	gage insert
right hand						
MTFNR12CA16	50	20,0	55	-9.0	-5.0	TN..160408/TN..332
MTFNR16CA16	60	25,0	63	-9.0	-5.0	TN..160408/TN..332
MTFNR20CA22	70	25,0	70	-9.0	-5.0	TN..220408/TN..432
left hand						
MTFNL12CA16	50	20,0	55	-9.0	-5.0	TN..160408/TN..332
MTFNL16CA16	60	25,0	63	-9.0	-5.0	TN..160408/TN..332
MTFNL20CA22	70	25,0	70	-9.0	-5.0	TN..220408/TN..432

O.D./I.D. Tooling

■ Spare Parts



D min	shim	lock pin	hex	clamp	clamping screw	hex	radial adjusting screw	hex	axial adjusting screw	mounting screw	hex	washer
50	—	KLM33L	2 mm	CKM34	STCM38	2 mm	KUAM22	2 mm	KUAM31	191.406	4 mm	CSWM 060 050
60	ITSN322	KLM34L	2 mm	CKM34	STCM9	2 mm	KUAM25	2 mm	KUAM32	191.407	5 mm	CSWM 080 050
70	ITSN433	KLM46	2.5 mm	CKM35	STCM37	2.5 mm	KUAM25	2.5 mm	KUAM32	191.407	5 mm	CSWM 080 050



See pages B66–B73 and B179–B180 for inserts.

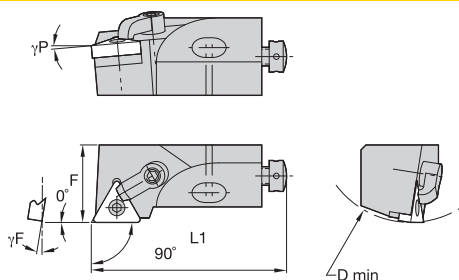

MTGN 90°

O.D./I.D. Tooling

catalogue number	D min	F	L1	γF°	γP°	gage insert
right hand						
MTGNR12CA16	50	20,0	55	-9.0	-5.0	TN..160408/TN..332
MTGNR16CA16	60	25,0	63	-9.0	-5.0	TN..160408/TN..332
MTGNR20CA22	70	25,0	70	-9.0	-5.0	TN..220408/TN..432
left hand						
MTGNL12CA16	50	20,0	55	-9.0	-5.0	TN..160408/TN..332
MTGNL16CA16	60	25,0	63	-9.0	-5.0	TN..160408/TN..332
MTGNL20CA22	70	25,0	70	-9.0	-5.0	TN..220408/TN..432

Spare Parts



D min	shim	lock pin	hex	clamp	clamp screw	hex	radial adjusting screw	hex	axial adjusting screw	mounting screw	hex	washer
50	—	KLM33L	2 mm	CKM34	STCM38	2 mm	KUAM22	2 mm	KUAM31	191.406	4 mm	CSWM 060 050
60	ITSN322	KLM34L	2 mm	CKM34	STCM9	2.5 mm	KUAM25	2.5 mm	KUAM32	191.407	5 mm	CSWM 080 050
70	ITSN433	KLM46	2.5 mm	CKM35	STCM37	2.5 mm	KUAM25	2.5 mm	KUAM32	191.407	5 mm	CSWM 080 050



See pages B66–B73 and B179–B180 for inserts.

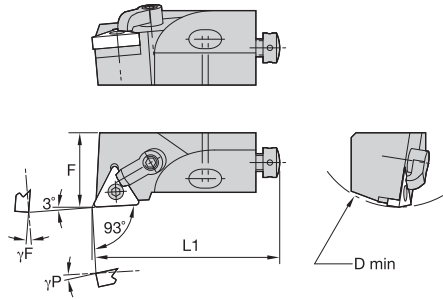

■ MTJN 93°

catalogue number	D min	F	L1	γF°	γP°	gage insert
right hand MTJNR12CA16	50	20,0	55	-9.0	-5.0	TN..160408/TN..332
left hand MTJNL12CA16	50	20,0	55	-9.0	-5.0	TN..160408/TN..332

■ Spare Parts



D min	shim	lock pin	hex	clamp	clamp screw	hex	radial adjusting screw	hex	axial adjusting screw	mounting screw	hex	washer
50	—	KLM33L	2 mm	CKM34	STCM38	2 mm	KUAM22	2 mm	KUAM31	191.406	4 mm	CSWM 060 050

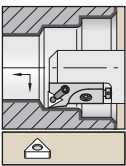

See pages B66–B73 and B179–B180 for inserts.

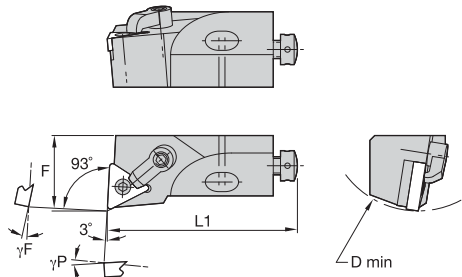

■ MTUN 93°

catalogue number	D min	F	L1	γF°	γP°	gage insert
right hand MTUNR16CA16	60	25,0	63	-9.0	-5.0	TN..160408/TN..332
MTUNR20CA22	70	25,0	70	-9.0	-5.0	TN..220408/TN..432
left hand MTUNL12CA16	50	20,0	55	-9.0	-5.0	TN..160408/TN..332
MTUNL16CA16	60	25,0	63	-9.0	-5.0	TN..160408/TN..332
MTUNL20CA22	70	25,0	70	-9.0	-5.0	TN..220408/TN..432

■ Spare Parts



D min	shim	lock pin	hex	clamp	clamp screw	hex	radial adjusting screw	hex	axial adjusting screw	mounting screw	hex	washer
50	—	KLM33L	2 mm	CKM34	STCM38	2 mm	KUAM22	2 mm	KUAM31	191.406	4 mm	CSWM 060 050
60	ITSN322	KLM34L	2 mm	CKM34	STCM9	2.5 mm	KUAM25	2.5 mm	KUAM32	191.407	5 mm	CSWM 080 050
70	ITSN433	KLM46	—	CKM35	STCM37	2.5 mm	KUAM25	2.5 mm	KUAM33	191.407	5 mm	CSWM 080 050
70	ITSN433	KLM46	—	CKM37	STCM40	2.5 mm	KUAM25	2.5 mm	KUAM33	191.407	5 mm	CSWM 080 050

NOTE: Select spare parts based off of D min and the insert size selected.

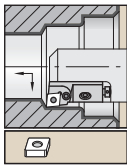

See pages B40–B49 and B174–B176 for inserts.

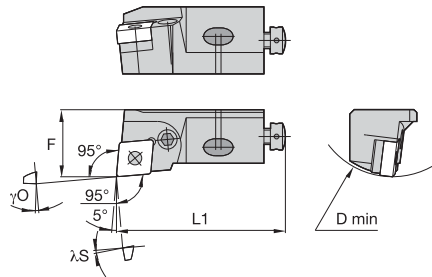

O.D./I.D. Tooling

■ PCLN 95°

catalogue number	D min	F	L1	λS°	γO°	gage insert
right hand						
PCLNR12CA12	50	20,0	55	-6.0	-9.0	CN..120408/CN..432
PCLNR16CA12	60	25,0	63	-6.0	-7.0	CN..120408/CN..432
left hand						
PCLNL16CA12	60	25,0	63	-6.0	-7.0	CN..120408/CN..432

■ Spare Parts



D min	shim	shim pin	toggle lever	lever screw	wrench size lever screw	radial adjusting screw	hex	axial adjusting screw	mounting screw	hex	washer
50	—	—	511.022	514.122	10 IP	KUAM28	2 mm	KUAM31	191.406	4 mm	CSWM 060 050
60	512.112	513.023	511.023	514.123	15 IP	KUAM23	2.5 mm	KUAM32	191.407	5 mm	CSWM 080 050

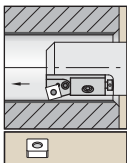

See pages B59–B66 and B178–B179 for inserts.

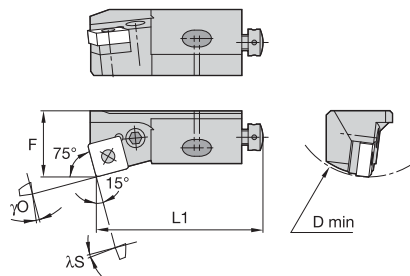

■ PSKN 75°

catalogue number	D min	F	L1	L1A	λS°	γO°	gage insert
right hand							
PSKNR12CA-12	50	20,0	55	3	-8.0	-6.0	SN..120408/SN..432
left hand							
PSKNL16CA-12	60	25,0	63	3	-6.0	-6.0	SN..120408/SN..432

■ Spare Parts



D min	shim	shim pin	toggle lever	lever screw	wrench size lever screw	radial adjusting screw	hex	axial adjusting screw	mounting screw	hex	washer
50	—	—	511.022	514.122	10 IP	KUAM28	2 mm	KUAM31	191.406	4 mm	CSWM 060 050
60	512.063	513.023	511.023	514.123	15 IP	KUAM23	2.5 mm	KUAM32	191.407	5 mm	CSWM 080 050



See pages B59–B66 and B178–B179 for inserts.

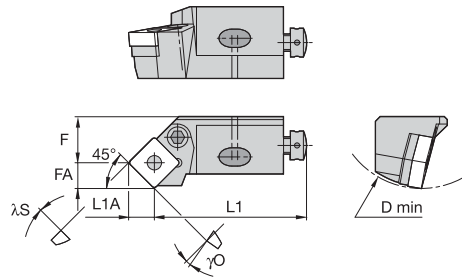

■ PSSN 45°

catalogue number	D min	F	L1	FA	L1A	λS°	γO°	gage insert
right hand								
PSSNR12CA-12	50	20,0	47	8,7	8,3	-10.0	0.0	SN..120408/SN..432
PSSNR16CA-12	60	25,0	53	8,7	8,3	-10.0	0.0	SN..120408/SN..432
left hand								
PSSNL12CA12	50	11,3	47	8,7	8,3	0.0	-10.0	SN..120408/SN..432
PSSNL16CA12	60	16,3	53	8,7	8,3	0.0	-10.0	SN..120408/SN..432

O.D./I.D. Tooling

■ Spare Parts



D min	shim	shim pin	toggle lever	lever screw	wrench size lever screw	radial adjusting screw	hex	axial adjusting screw	mounting screw	hex	washer
50	—	—	511.022	514.122	10 IP	KUAM28	2 mm	KUAM31	191.406	4 mm	CSWM 060 050
60	512.063	513.023	511.023	514.123	15 IP	KUAM23	2.5 mm	KUAM32	191.407	5 mm	CSWM 080 050

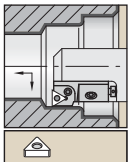

See pages B66–B73 and B179–B180 for inserts.

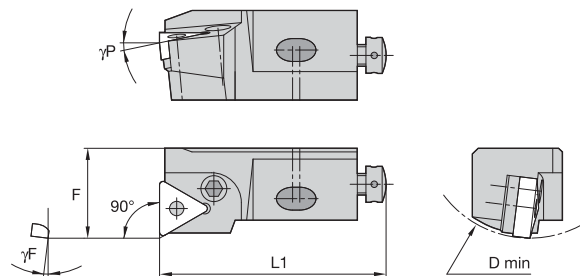

■ PTFN 90°

catalogue number	D min	F	L1	γF°	γP°	gage insert
right hand						
PTFNR12CA-16	50	20,0	55	-7.0	-6.0	TN..160408/TN..332
left hand						
PTFNL12CA-16	50	20,0	55	-7.0	-6.0	TN..160408/TN..332

■ Spare Parts

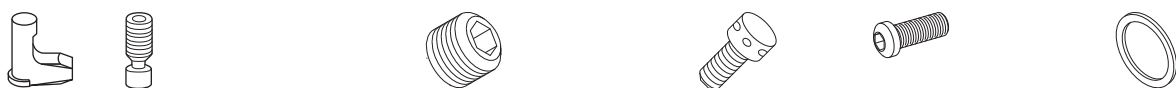

D min	toggle lever	lever screw	wrench size lever screw	radial adjusting screw	hex	axial adjusting screw	mounting screw	hex	washer
50	511.030	514.112	8 IP	KUAM28	2 mm	KUAM31	191.406	4 mm	CSWM 060 050

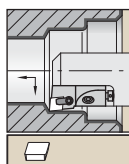

See pages B84 and B185 for inserts.

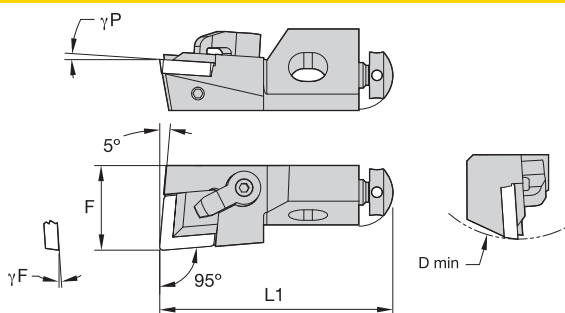

CCLP 95°

catalogue number	D min	F	L1	γF°	γP°	gage insert
right hand CCLPR12CA12	50	20,0	55	3.5	3.5	CP..120308/CP..422
left hand CCLPL12CA12	50	20,0	55	3.5	3.5	CP..120308/CP..422

O.D./I.D. Tooling

Spare Parts



D min	clamp	clamp screw	hex	radial adjusting screw	hex	axial adjusting screw	mounting screw	hex	washer
50	CKM34	STCM38	2 mm	KUAM22	2 mm	KUAM31	191.406	4 mm	CSWM 060 050

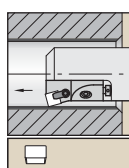

See pages B85–B86 and B130 for inserts.

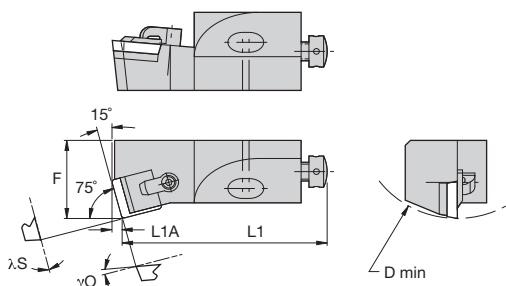

CSKP 75°

catalogue number	D min	F	L1	L1A	λS°	γO°	gage insert
right hand CSKPR10CA09	40	14,0	50	2,2	0.0	5.0	SP..090308/SP..322
CSKPR12CA12	50	20,0	55	3,1	0.0	5.0	SP..120308/SP..422
CSKPR20CA12	70	25,0	70	3,1	0.0	5.0	SP..120308/SP..422
left hand CSKPL12CA12	50	20,0	55	3,1	0.0	5.0	SP..120308/SP..422
CSKPL20CA12	70	25,0	70	3,1	0.0	5.0	SP..120308/SP..422

Spare Parts



D min	shim	shim screw	hex	clamp	clamp screw	hex	radial adjusting screw	hex	axial adjusting screw	mounting screw	hex	washer
40	—	—	—	CKM34	STCM38	2 mm	KUAM28	2 mm	KUAM30	191.405	4 mm	CSWM 060 050
50	—	—	—	CKM34	STCM38	2 mm	KUAM22	2 mm	KUAM31	191.406	4 mm	CSWM 060 050
70	SM840	MS109	2 mm	CKM34	STCM38	2 mm	KUAM24	2 mm	KUAM32	191.407	5 mm	CSWM 080 050

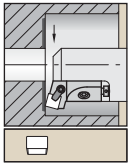

See pages B85–B86 and B130 for inserts.

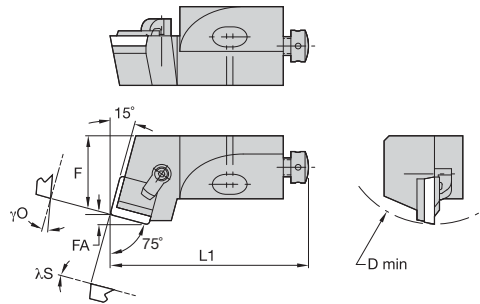

■ CSRP 75°

catalogue number	D min	F	L1	FA	λS°	γO°	gage insert
right hand							
CSRPR10CA09	40	14,0	50	2,2	0.0	0.0	SP..090308/SP..322
CSRPR12CA12	50	20,0	55	3,0	3.0	0.0	SP..120308/SP..422
left hand							
CSRPL10CA09	40	14,0	50	2,2	0.0	0.0	SP..090308/SP..322
CSRPL12CA12	50	20,0	55	3,0	3.0	0.0	SP..120308/SP..422

O.D./I.D. Tooling

■ Spare Parts



D min	clamp	clamp screw	hex	radial adjusting screw	hex	axial adjusting screw	mounting screw	hex	washer
40	CKM34	STCM38	2 mm	KUAM28	2 mm	KUAM30	191.405	4 mm	CSWM 060 050
50	CKM34	STCM38	2 mm	KUAM22	2 mm	KUAM31	191.406	4 mm	CSWM 060 050

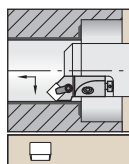

See pages B85–B86 and B130 for inserts.

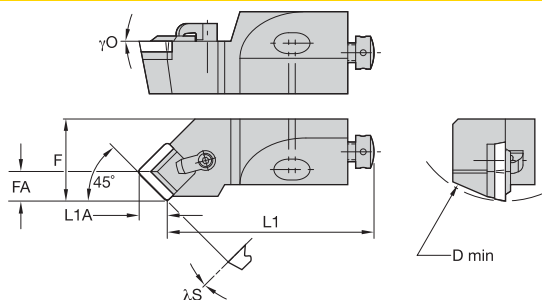

O.D./I.D. Tooling

■ **CSSP 45°**

catalogue number	D min	F	L1	FA	L1A	λS°	γO°	gage insert
right hand								
CSSPR10CA09	40	14,0	44	6,5	6,1	0.0	0.0	SP..090308/SP..322
CSSPR12CA12	50	20,0	47	8,3	8,3	0.0	0.0	SP..120308/SP..422
CSSPR16CA12	60	25,0	53	8,3	8,3	0.0	0.0	SP..120308/SP..422
left hand								
CSSPL10CA09	40	14,0	44	6,5	6,1	0.0	0.0	SP..090308/SP..322
CSSPL12CA12	50	20,0	47	8,3	8,3	0.0	0.0	SP..120308/SP..422
CSSPL16CA12	60	25,0	53	8,3	8,3	0.0	0.0	SP..120308/SP..422
CSSPL20CA12	70	25,0	60	8,3	8,3	0.0	0.0	SP..120308/SP..422

■ **Spare Parts**



D min	shim	shim screw	hex	clamp	clamp screw	hex	radial adjusting screw	hex	axial adjusting screw	mounting screw	hex	washer
40	—	—	—	CKM34	STCM38	2 mm	KUAM28	2 mm	KUAM30	191.405	4 mm	CSWM 060 050
50	—	—	—	CKM34	STCM38	2 mm	KUAM22	2 mm	KUAM31	191.406	4 mm	CSWM 060 050
60	SM840	CS109PKG	2 mm	CKM34	STCM9	2.5 mm	KUAM25	2.5 mm	KUAM32	191.407	5 mm	CSWM 080 050
70	SM840	MS111	2 mm	CKM20	STCM11	3 mm	KUAM26	3 mm	KUAM32	191.407	5 mm	CSWM 080 050

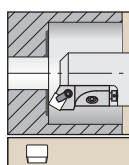

See pages B85–B86 and B130 for inserts.

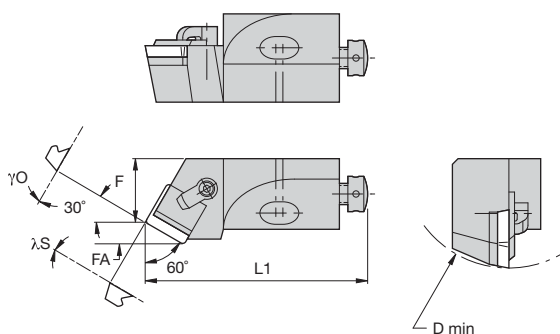

■ **CSTP 60°**

catalogue number	D min	F	L1	FA	λS°	γO°	gage insert
right hand							
CSTPR10CA09	40	9,0	50	4,3	0.0	0.0	SP..090308/SP..322

■ **Spare Parts**



D min	clamp	clamp screw	hex	radial adjusting screw	hex	axial adjusting screw	mounting screw	hex	washer
40	CKM34	STCM38	2 mm	KUAM28	2 mm	KUAM30	191.405	4 mm	CSWM 060 050

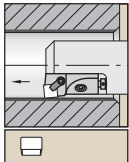

See pages B86–B87 and B130 for inserts.

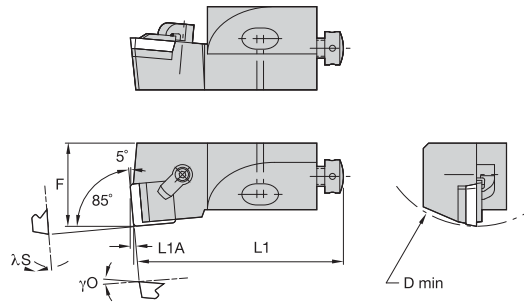
CSYP 85°

catalogue number	D min	F	L1	L1A	λS°	γO°	gage insert
right hand CSYPR10CA09	40	14,0	50	0,8	0.0	5.0	SP..090308/SP..322
left hand CSYPL10CA09	40	14,0	50	0,8	0.0	5.0	SP..090308/SP..322

Spare Parts

D min	clamp	clamp screw	hex	radial adjusting screw	hex	axial adjusting screw	mounting screw	hex	washer
40	CKM34	STCM38	2 mm	KUAM28	2 mm	KUAM30	191.405	4 mm	CSWM 060 050

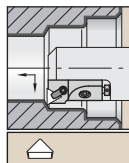

See pages B86–B87 and B130 for inserts.

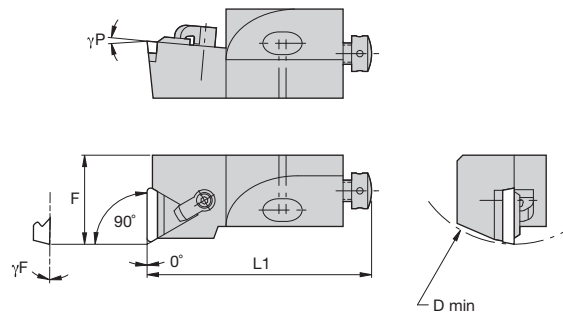
CTFP 90°

catalogue number	D min	F	L1	γF°	γP°	gage insert
right hand CTFPR10CA11	40	14,0	50	0.0	5.0	TP..110304/TP..421
CTFPR12CA16	50	20,0	55	0.0	5.0	TP..160308/TP..322
CTFPR16CA16	60	25,0	63	0.0	5.0	TP..160308/TP..322
CTFPR20CA22	70	25,0	70	0.0	5.0	TP..220408/TP..432
left hand CTFPL10CA11	40	14,0	50	0.0	5.0	TP..110304/TP..421
CTFPL12CA16	50	20,0	55	0.0	5.0	TP..160308/TP..322
CTFPL16CA16	60	25,0	63	0.0	5.0	TP..160308/TP..322

Spare Parts

D min	shim	shim screw	hex	clamp	clamp screw	hex	radial adjusting screw	hex	axial adjusting screw	mounting screw	hex	washer
40	—	—	—	CKM34	STCM38	2 mm	KUAM28	2 mm	KUAM30	191.405	4 mm	CSWM 060 050
50	—	—	—	CKM34	STCM38	2 mm	KUAM22	2 mm	KUAM31	191.406	4 mm	CSWM 060 050
60	SM841	MS109	2 mm	CKM34	STCM38	2 mm	KUAM24	2 mm	KUAM32	191.407	5 mm	CSWM 080 050
70	SM837	MS125	2.5 mm	CKM35	STCM8	4 mm	KUAM25	2.5 mm	KUAM32	191.407	5 mm	CSWM 080 050

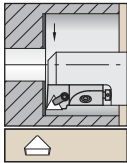

See pages B86–B87 and B130 for inserts.

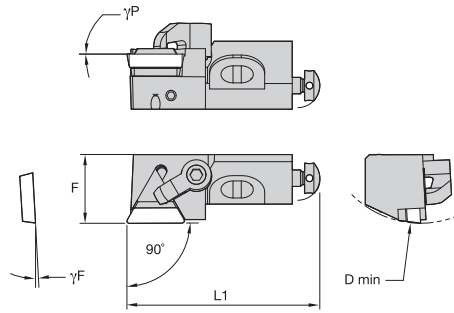

O.D./I.D. Tooling

CTGP 90°

catalogue number	D min	F	L1	γF°	γP°	gage insert
right hand						
CTGPR10CA11	40	14,0	50	3.0	0.0	TP..110304/TP..421
CTGPR12CA16	50	20,0	55	3.0	0.0	TP..160308/TP..322
CTGPR16CA16	60	25,0	63	3.0	0.0	TP..160308/TP..322
CTGPR20CA22	70	25,0	70	3.0	0.0	TP..220408/TP..432
left hand						
CTGPL12CA16	50	20,0	55	3.0	0.0	TP..160308/TP..322
CTGPL20CA22	70	25,0	70	3.0	0.0	TP..220408/TP..432

Spare Parts



D min	shim	shim screw	hex	clamp	clamp screw	hex	radial adjusting screw	hex	axial adjusting screw	mounting screw	hex	washer
40	—	—	—	CKM34	STCM38	2 mm	KUAM28	2 mm	KUAM30	191.405	4 mm	CSWM 060 050
50	—	—	—	CKM34	STCM38	2 mm	KUAM22	2 mm	KUAM31	191.406	4 mm	CSWM 060 050
60	SM841	MS109	2 mm	CKM34	STCM38	2 mm	KUAM24	2 mm	KUAM32	191.407	5 mm	CSWM 080 050
70	SM837	MS125	2.5 mm	CKM35	STCM8	4 mm	KUAM25	2.5 mm	KUAM32	191.407	5 mm	CSWM 080 050

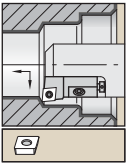

See pages B92–B95 and B189–B190 for inserts.

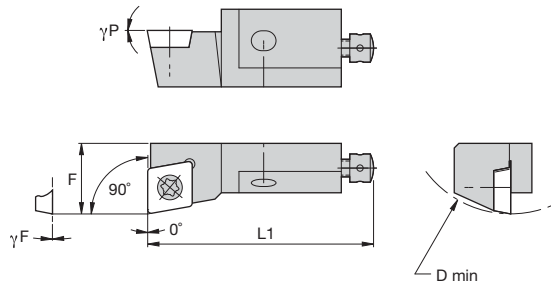

■ **SCFP 90°**

catalogue number	D min	F	L1	γF°	γP°	gage insert
right hand						
SCFPR06CA05	20	8,0	25	0.0	0.0	CP..050204/CP..18151
SCFPR08CA06	25	10,0	32	0.0	0.0	CP..060204/CP..2151
SCFPR10CA09	40	14,0	50	0.0	0.0	CPMT09T308
left hand						
SCFPL06CA05	20	8,0	25	0.0	0.0	CP..050204/CP..18151
SCFPL08CA06	25	10,0	32	0.0	0.0	CP..060204/CP..2151

O.D./I.D. Tooling

■ **Spare Parts**



D min	insert screw	Torx	radial adjusting screw	hex	axial adjusting screw	mounting screw	hex	washer
20	MS1933	T7	KUAM34	1.5 mm	KUAM35	MS2173	2 mm	CSWM 035 040
25	MS1153	T7	KUAM34	1.5 mm	KUAM20	MS2175	2.5 mm	CSWM 040 050
40	MS1155	T15	KUAM28	2 mm	KUAM30	191.405	4 mm	CSWM 060 050

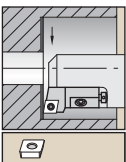

See pages B92–B95 and B189–B190 for inserts.

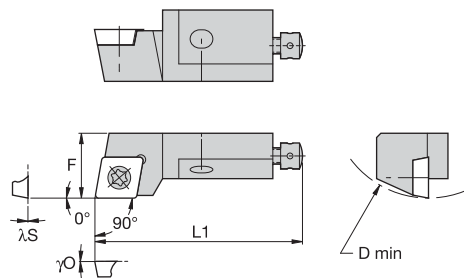

■ **SCGP 90°**

catalogue number	D min	F	L1	λS°	γO°	gage insert
right hand						
SCGPR08CA06	25	10,0	32	0.0	0.0	CP..060204/CP..2151
left hand						
SCGPL08CA06	25	10,0	32	0.0	0.0	CP..060204/CP..2151

■ **Spare Parts**



D min	insert screw	Torx	radial adjusting screw	hex	axial adjusting screw	mounting screw	hex	washer
25	MS1153	T7	KUAM34	1.5 mm	KUAM20	MS2175	2.5 mm	CSWM 040 050

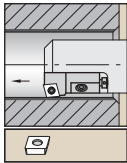

See pages B92–B95 and B189–B190 for inserts.

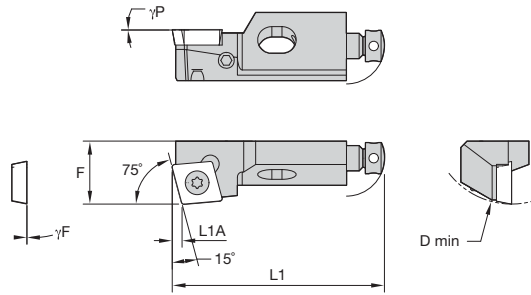

SCKP 75°

catalogue number	D min	F	L1	L1A	γF°	γP°	gage insert
right hand SCKPR08CA06	25	10,0	32	1,6	0.0	0.0	CP..060204/CP..2151
left hand SCKPL08CA06	25	10,0	32	1,6	0.0	0.0	CP..060204/CP..2151

O.D./I.D. Tooling

Spare Parts



D min	insert screw	Torx	radial adjusting screw	hex	axial adjusting screw	mounting screw	hex	washer
25	MS1153	T7	KUAM34	1.5 mm	KUAM20	MS2175	2.5 mm	CSWM 040 050
25	MS1153	T7	KUAM34	2 mm	KUAM20	MS2175	2.5 mm	CSWM 040 050

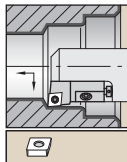

See pages B88–B91 and B187–B188 for inserts.

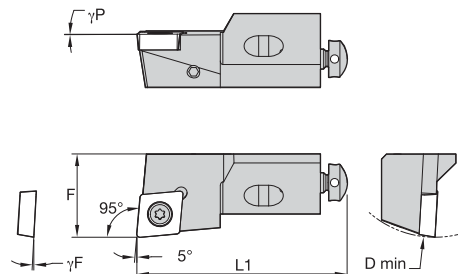

SCLC 95°

catalogue number	D min	F	L1	γF°	γP°	gage insert
right hand SCLCR12CA12	50	20,0	55	-3.0	0.0	CC..120408/CC..432
SCLCR16CA12	60	25,0	63	-3.0	0.0	CC..120408/CC..432
left hand SCLCL12CA12	50	20,0	55	-3.0	0.0	CC..120408/CC..432
SCLCL16CA12	60	25,0	63	-3.0	0.0	CC..120408/CC..432

Spare Parts



D min	insert screw	Torx	radial adjusting screw	hex	axial adjusting screw	mounting screw	hex	washer
50	MS1157	T15	KUAM23	2.5 mm	KUAM31	191.406	4 mm	CSWM 060 050
60	MS1157	T15	KUAM25	2.5 mm	KUAM32	191.407	5 mm	CSWM 080 050

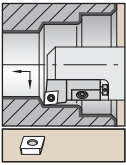

See pages B92–B95 and B189–B190 for inserts.

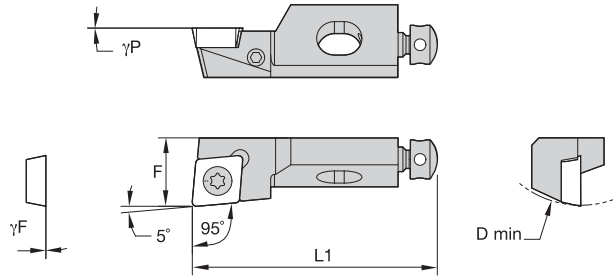

■ **SCLP 95°**

catalogue number	D min	F	L1	γF°	γP°	gage insert
right hand						
SCLPR06CA05	20	8,0	25	0.0	0.0	CP..050204/CP..18151
SCLPR08CA06	25	10,0	32	0.0	0.0	CP..060204/CP..2151
SCLPR10CA09	40	14,0	50	0.0	0.0	CP..09T308/CP..3252
left hand						
SCLPL06CA05	20	8,0	25	0.0	0.0	CP..050204/CP..18151
SCLPL08CA06	25	10,0	32	0.0	0.0	CP..060204/CP..2151
SCLPL10CA09	40	14,0	50	0.0	0.0	CP..09T308/CP..3252

■ **Spare Parts**



D min	insert screw	Torx	radial adjusting screw	hex	axial adjusting screw	mounting screw	hex	washer
20	MS1933	T7	KUAM34	1.5 mm	KUAM35	MS2173	2 mm	CSWM 035 040
25	MS1153	T7	KUAM34	1.5 mm	KUAM20	MS2175	2.5 mm	CSWM 040 050
40	MS1155	T15	KUAM28	2 mm	KUAM30	191.405	4 mm	CSWM 060 050

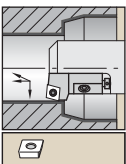

See pages B92–B95 and B189–B190 for inserts.

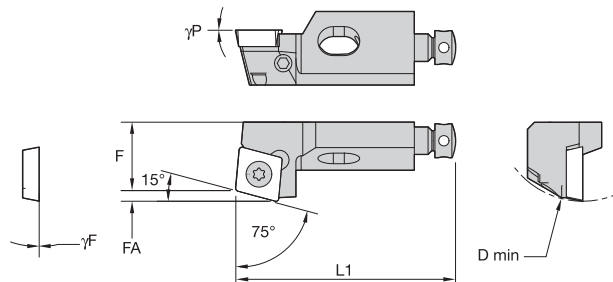

■ **SCRP 75°**

catalogue number	D min	F	L1	FA	γF°	γP°	gage insert
right hand							
SCRPR08CA06	25	10,0	32	1,5	0.0	0.0	CP..060204/CP..2151
left hand							
SCRPL08CA06	25	10,0	32	1,5	0.0	0.0	CP..060204/CP..2151

■ **Spare Parts**



D min	insert screw	Torx	radial adjusting screw	hex	axial adjusting screw	mounting screw	hex	washer
25	MS1153	T7	KUAM34	1.5 mm	KUAM20	MS2175	2.5 mm	CSWM 040 050

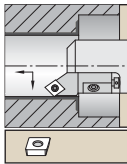

See pages B92–B95 and B189–B190 for inserts.

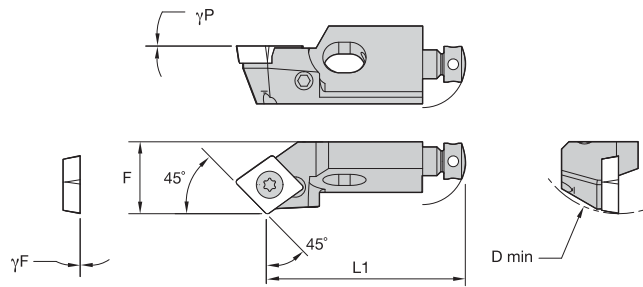

O.D./I.D. Tooling

SCSP 45°

catalogue number	D min	F	L1	γF°	γP°	gage insert
right hand						
SCSPR06CA05	20	8,0	21	0.0	0.0	CP..050204/CP..18151
SCSPR08CA06	25	10,0	28	0.0	0.0	CP..060204/CP..2151
left hand						
SCSPL06CA05	20	8,0	21	0.0	0.0	CP..050204/CP..18151
SCSPL08CA06	25	10,0	28	0.0	0.0	CP..060204/CP..2151

Spare Parts



D min	insert screw	Torx	radial adjusting screw	hex	axial adjusting screw	mounting screw	hex	washer
20	MS1933	T7	—	—	KUAM35	MS2173	2 mm	CSWM 035 040
25	MS1153	T7	KUAM34	1.5 mm	KUAM20	MS2175	2.5 mm	CSWM 040 050

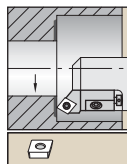

See pages B92–B95 and B189–B190 for inserts.

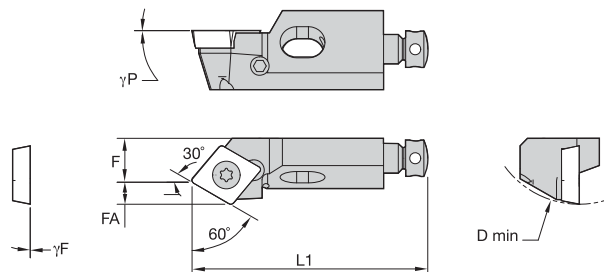

SCTP 60°

catalogue number	D min	F	L1	FA	γF°	γP°	gage insert
right hand							
SCTPR06CA05	20	5,5	25	2,6	0.0	0.0	CP..050204/CP..18151
SCTPR08CA06	25	6,0	32	3,0	0.0	0.0	CP..060204/CP..2151
left hand							
SCTPL08CA06	25	6,0	32	3,0	0.0	0.0	CP..060204/CP..2151

Spare Parts



D min	insert screw	Torx	radial adjusting screw	hex	axial adjusting screw	mounting screw	hex	washer
20	MS1933	T7	—	—	KUAM35	MS2173	2 mm	CSWM 035 040
25	MS1153	T7	KUAM34	1.5 mm	KUAM20	MS2175	2.5 mm	CSWM 040 050



See pages B92–B95 and B189–B190 for inserts.

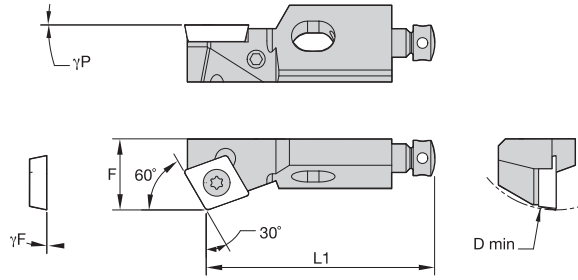

■ **SCWP 60°**

catalogue number	D min	F	L1	γF°	γP°	gage insert
right hand SCWPR08CA06	25	10,0	32	0.0	0.0	CP..060204/CP..2151
left hand SCWPL08CA06	25	10,0	32	0.0	0.0	CP..060204/CP..2151

■ **Spare Parts**



D min	insert screw	Torx	radial adjusting screw	hex	axial adjusting screw	mounting screw	hex	washer
25	MS1153	T7	KUAM34	1.5 mm	KUAM20	MS2175	2.5 mm	CSWM 040 050

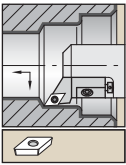

See pages B98–B100 and B192–B194 for inserts.

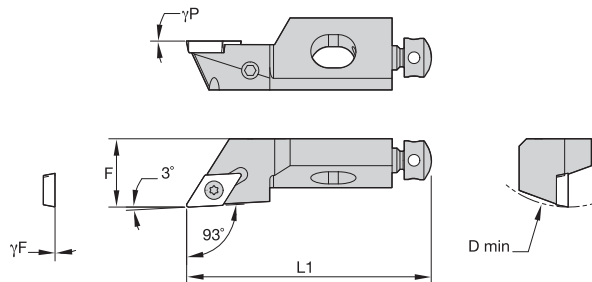

■ **SDJP 93°**

catalogue number	D min	F	L1	γF°	γP°	gage insert
right hand SDJPR10CA07	40	14,0	50	0.0	0.0	DP..070204/DP..2151
left hand SDJPL10CA07	40	14,0	50	0.0	0.0	DP..070204/DP..2151

■ **Spare Parts**



D min	insert screw	Torx	radial adjusting screw	hex	axial adjusting screw	mounting screw	hex	washer
40	MS1153	T7	KUAM28	2 mm	KUAM30	191.405	4 mm	CSWM 060 050

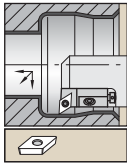

See pages B98–B100 and B192–B194 for inserts.

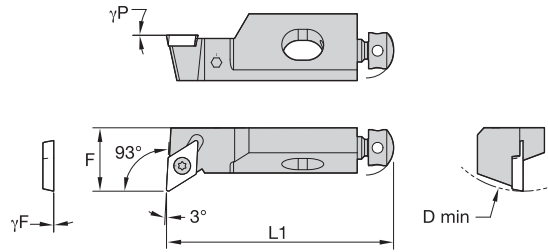

O.D./I.D. Tooling

SDUP 93°

catalogue number	D min	F	L1	γF°	γP°	gage insert
right hand SDUPR10CA07	40	14,0	50	0.0	0.0	DP..070204/DP..2151

Spare Parts



D min	insert screw	Torx	radial adjusting screw	hex	axial adjusting screw	mounting screw	hex	washer
40	MS1153	T7	KUAM28	2 mm	KUAM30	191.405	4 mm	CSWM 060 050

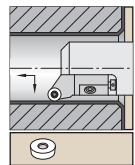

See pages B100–B102 for inserts.

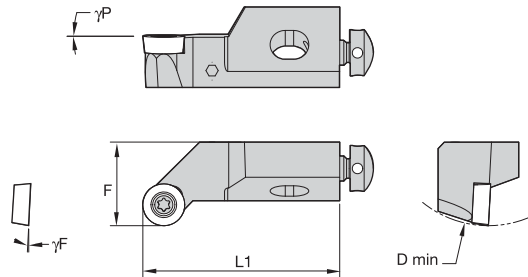

SRGC

catalogue number	D min	F	L1	γF°	γP°	gage insert
right hand SRGCR08CA06	25	10,0	32	-4.0	0.0	RC..0602M0/RC..215
SRGCR10CA08	40	14,0	50	-3.0	0.0	RC..0803M0/RC..0803M0
SRGCR12CA10	50	20,0	55	-3.0	0.0	RC..10T3M0/RC..10T3M0
left hand SRGCL08CA06	25	10,0	32	-4.0	0.0	RC..0602M0/RC..215
SRGCL12CA10	50	20,0	55	-3.0	0.0	RC..10T3M0/RC..10T3M0

Spare Parts



D min	insert screw	Torx	radial adjusting screw	hex	axial adjusting screw	mounting screw	hex	washer
25	MS1153	T7	KUAM34	1.5 mm	KUAM20	MS2175	2.5 mm	CSWM 040 050
40	MS1154	T9	KUAM28	2 mm	KUAM30	191.405	4 mm	CSWM 060 050
50	MS1155	T15	KUAM23	2.5 mm	KUAM31	191.406	4 mm	CSWM 060 050

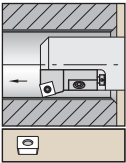

See pages B103–B104 for inserts.

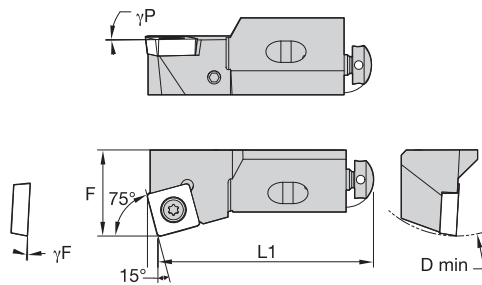

■ **SSKC 75°**

catalogue number	D min	F	L1	γF°	γP°	gage insert
right hand SSKCR12CA12	50	20,0	55	-3.0	0.0	SC..120408/SC..432
SSKCR16CA12	60	25,0	63	-3.0	0.0	SC..120408/SC..432
left hand SSKCL12CA12	50	20,0	55	-3.0	0.0	SC..120408/SC..432

■ **Spare Parts**



D min	insert screw	Torx	radial adjusting screw	hex	axial adjusting screw	mounting screw	hex	washer
50	MS1157	T15	KUAM23	2.5 mm	KUAM31	191.406	4 mm	CSWM 060 050
60	MS1157	T15	KUAM25	2.5 mm	KUAM32	191.407	5 mm	CSWM 080 050

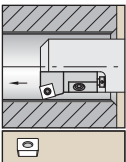

See pages B104–B106 for inserts.

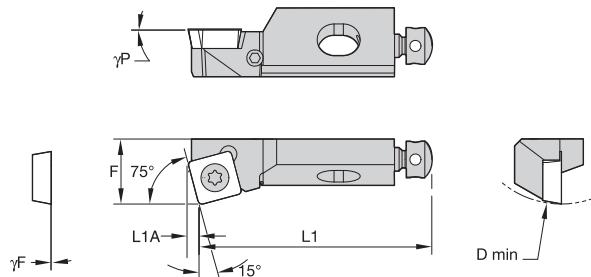

■ **SSKP 75°**

catalogue number	D min	F	L1	γF°	γP°	gage insert
right hand SSKPR10CA09	40	14,0	50	0.0	0.0	SP..09T308/SP..3252
left hand SSKPL10CA09	40	14,0	50	0.0	0.0	SP..09T308/SP..3252

■ **Spare Parts**



D min	insert screw	Torx	radial adjusting screw	hex	axial adjusting screw	mounting screw	hex	washer
40	MS1155	T15	KUAM28	2 mm	KUAM30	191.405	4 mm	CSWM 060 050

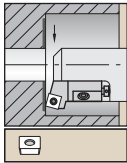

See pages B103–B104 for inserts.

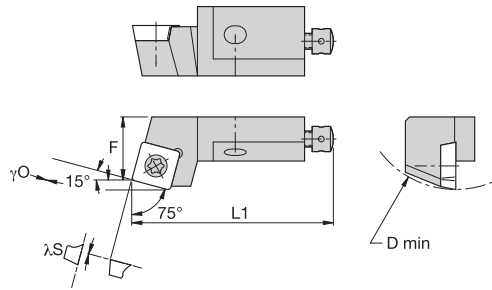

SSRC 75°

catalogue number	D min	F	L1	γO°	λS°	gage insert
right hand SSRCR12CA12	50	20,0	55	0.0	-3.0	SC..120408/SC..432
left hand SSRCL12CA12	50	20,0	55	0.0	-3.0	SC..120408/SC..432

O.D./I.D. Tooling

Spare Parts



D min	insert screw	Torx	radial adjusting screw	hex	axial adjusting screw	mounting screw	hex	washer
50	MS1157	T15	KUAM23	2.5 mm	KUAM31	191.406	4 mm	CSWM 060 050

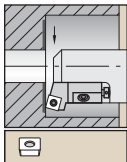

See pages B104–B106 for inserts.

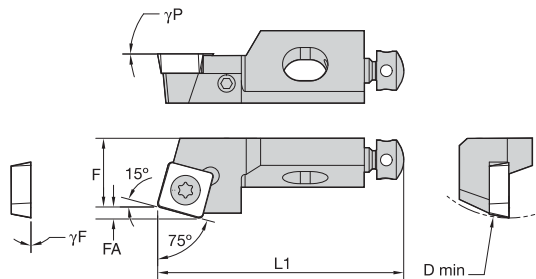

SSRP 75°

catalogue number	D min	F	L1	γF°	γP°	gage insert
right hand SSRPR10CA09	40	14,0	50	0.0	0.0	SP..09T308/SP..3252
left hand SSRPL10CA09	40	14,0	50	0.0	0.0	SP..09T308/SP..3252

Spare Parts



D min	insert screw	Torx	radial adjusting screw	hex	axial adjusting screw	mounting screw	hex	washer
40	MS1155	T15	KUAM28	2 mm	KUAM30	191.405	4 mm	CSWM 060 050

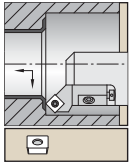

See pages B103–B104 for inserts.

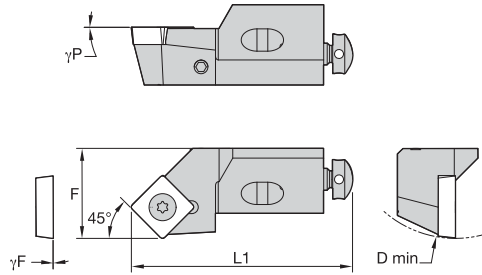

■ **SSSC 45°**

catalogue number	D min	F	L1	γF°	γP°	gage insert
right hand SSSCR12CA12	50	20,0	47	-3.0	0.0	SC..120408/SC..432
SSSCR16CA12	60	25,0	53	0.0	0.0	SC..120408/SC..432
left hand SSSCL12CA12	50	20,0	47	-3.0	0.0	SC..120408/SC..432

■ **Spare Parts**



D min	insert screw	Torx	radial adjusting screw	hex	axial adjusting screw	mounting screw	hex	washer
50	MS1157	T15	KUAM23	2.5 mm	KUAM31	191.406	4 mm	CSWM 060 050
60	MS1157	T15	KUAM25	2.5 mm	KUAM32	191.407	5 mm	CSWM 080 050

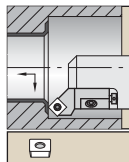

See pages B104–B106 for inserts.

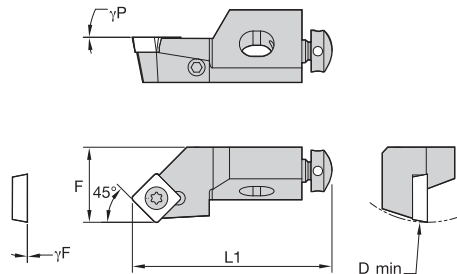

■ **SSSP 45°**

catalogue number	D min	F	L1	γF°	γP°	gage insert
right hand SSSPR10CA09	40	14,0	44	0.0	0.0	SP..09T308/SP..3252
SSSPR12CA09	50	20,0	47	0.0	0.0	SP..09T308/SP..3252
left hand SSSPL10CA09	40	14,0	44	0.0	0.0	SP..09T308/SP..3252

■ **Spare Parts**



D min	insert screw	Torx	radial adjusting screw	hex	axial adjusting screw	mounting screw	hex	washer
40	MS1155	T15	KUAM28	2 mm	KUAM30	191.405	4 mm	CSWM 060 050
50	MS1155	T15	KUAM23	2.5 mm	KUAM31	191.406	4 mm	CSWM 060 050

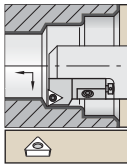

See pages B109–B112 and B195–B196 for inserts.

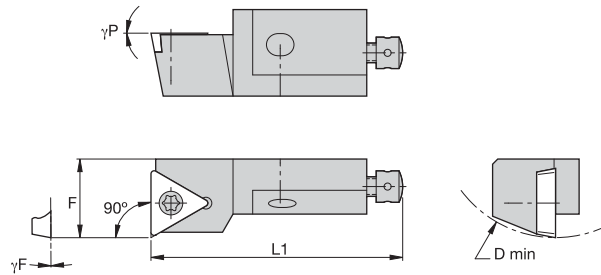

O.D./I.D. Tooling

■ **STFP 90°**

catalogue number	D min	F	L1	γF°	γP°	gage insert
right hand						
STFPR08CA09	25	10,0	32	0.0	0.0	TP..090204/TP..18151
STFPR10CA11	40	14,0	50	0.0	0.0	TP..110204/TP..2151
STFPR12CA16	50	20,0	55	0.0	0.0	TP..16T308/TP..3252
STFPR16CA16	60	25,0	63	0.0	0.0	TP..16T308/TP..3252
left hand						
STFPL08CA09	25	10,0	32	0.0	0.0	TP..090204/TP..18151
STFPL10CA11	40	14,0	50	0.0	0.0	TP..110204/TP..2151
STFPL12CA16	50	20,0	55	0.0	0.0	TP..16T308/TP..3252

■ **Spare Parts**



D min	insert screw	Torx	radial adjusting screw	hex	axial adjusting screw	mounting screw	hex	washer
25	MS1152	T7	KUAM34	1.5 mm	KUAM20	MS2175	2.5 mm	CSWM 040 050
40	MS1153	T7	KUAM28	2 mm	KUAM30	191.405	4 mm	CSWM 060 050
50	MS1155	T15	KUAM23	2.5 mm	KUAM31	191.406	4 mm	CSWM 060 050
60	MS1155	T15	KUAM25	4 mm	KUAM32	191.407	5 mm	CSWM 080 050

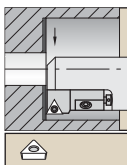

See pages B109–B112 and B195–B196 for inserts.

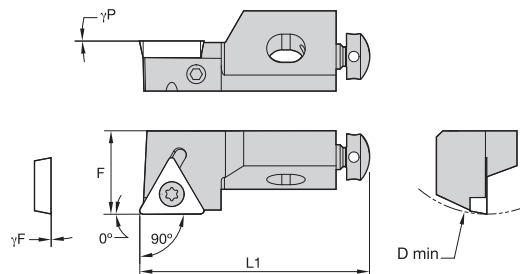

■ **STGP 90°**

catalogue number	D min	F	L1	γF°	γP°	gage insert
right hand						
STGPR08CA09	25	10,0	32	0.0	0.0	TP..090204/TP..18151
STGPR10CA11	40	14,0	50	0.0	0.0	TP..110204/TP..2151
STGPR12CA16	50	20,0	55	0.0	0.0	TP..16T308/TP..3252
left hand						
STGPL08CA09	25	10,0	32	0.0	0.0	TP..090204/TP..18151
STGPL10CA11	40	14,0	50	0.0	0.0	TP..110204/TP..2151

■ **Spare Parts**



D min	insert screw	Torx	radial adjusting screw	hex	axial adjusting screw	mounting screw	hex	washer
25	MS1152	T7	KUAM34	1.5 mm	KUAM20	MS2175	2.5 mm	CSWM 040 050
40	MS1153	T7	KUAM28	2 mm	KUAM30	191.405	4 mm	CSWM 060 050
50	MS1155	T15	KUAM23	2.5 mm	KUAM31	191.406	4 mm	CSWM 060 050

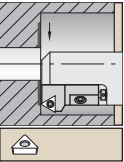

See pages B109–B112 and B195–B196 for inserts.

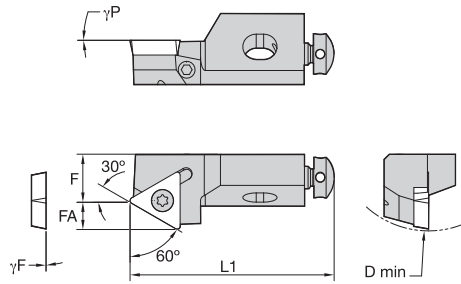

■ **STTP 60°**

catalogue number	D min	F	L1	γF°	γP°	gage insert
right hand						
STTPR08CA09	25	6,0	32	0.0	0.0	TP..090204/TP..18151
STTPR10CA11	40	9,0	50	0.0	0.0	TP..110204/TP..2151
STTPR12CA16	50	13,0	55	0.0	0.0	TP..16T308/TP..3252

■ **Spare Parts**



D min	insert screw	Torx	radial adjusting screw	hex	axial adjusting screw	mounting screw	hex	washer
25	MS1152	T7	KUAM34	1.5 mm	KUAM20	MS2175	2.5 mm	CSWM 040 050
40	MS1153	T7	KUAM28	2 mm	KUAM30	191.405	4 mm	CSWM 060 050
50	MS1155	T15	KUAM23	2.5 mm	KUAM31	191.406	4 mm	CSWM 060 050

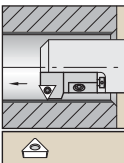

See pages B109–B112 and B195–B196 for inserts.

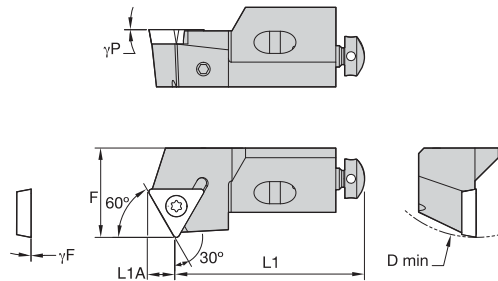

■ **STWP 60°**

catalogue number	D min	F	L1	γF°	γP°	gage insert
right hand						
STWPR08CA09	25	10,0	28	0.0	0.0	TP..090204/TP..18151
STWPR10CA11	40	14,0	44	0.0	0.0	TP..110204/TP..2151
STWPR12CA16	50	20,0	47	0.0	0.0	TP..16T308/TP..3252
STWPR16CA16	60	25,0	53	0.0	0.0	TP..16T308/TP..3252

■ **Spare Parts**



D min	insert screw	Torx	radial adjusting screw	hex	axial adjusting screw	mounting screw	hex	washer
25	MS1152	T7	KUAM34	1.5 mm	KUAM20	MS2175	2.5 mm	CSWM 040 050
40	MS1153	T7	KUAM28	2 mm	KUAM30	191.405	4 mm	CSWM 060 050
50	MS1155	T15	KUAM23	2.5 mm	KUAM31	191.406	4 mm	CSWM 060 050
60	MS1155	T15	KUAM25	2.5 mm	KUAM32	191.407	5 mm	CSWM 080 050



Grooving and Cut-Off

Grooving Application Guide	D2-D3
Grades and Grade Descriptions	D4-D7
A2 Cut-Off	D8-D25
A3 Deep Grooving	D26-D61
A4 Grooving and Turning	D62-D111
Top Notch Grooving	D112-D139
KGF and KGT Cut-Off Inserts	D142-D145

	Cut-Off	Grooving	Face Grooving
Application			
Top Notch™ Grooving generally recommended for cutting depth/width ratios of 1,5 or less		<p>Inserts</p> <ul style="list-style-type: none"> • Cutting widths from 0,8–9,5mm. • Cutting depths from 1,27–12,70mm. • Chip control, positive rake, and neutral flat top inserts are available. <p>O.D. Application</p> <ul style="list-style-type: none"> • Integral shank toolholders and KM™ heads are available. <p>I.D. Application</p> <ul style="list-style-type: none"> • Boring bars with a 11,5mm minimum bore diameter. 	<p>Minimum Face Groove Diameter Capabilities</p> <ul style="list-style-type: none"> • Standard inserts: 54–330mm depending on size. • NF/NFD face grooving inserts: 24–57mm. • All have unlimited maximum diameter. <p>Cutting Width Range</p> <ul style="list-style-type: none"> • Standard inserts: 0,8–9,5mm. • NF/NFD face grooving inserts: 2–6,35mm. <p>Cutting Depth Range</p> <ul style="list-style-type: none"> • Standard inserts: 1,27–12,7mm. • NF/NFD face grooving inserts: 3,8–6,35mm.
A4™ Grooving and Turning	<p>Cut-Off Capabilities</p> <ul style="list-style-type: none"> • Cut-off widths from 1,5–4,05mm. • Satisfies extreme demands for rigidity and dimensional accuracy. • Integral screw-clamping toolholders with 17mm maximum cutting depth available. • Economical double-edge inserts. 	<p>Inserts</p> <ul style="list-style-type: none"> • Cutting widths from 2–10,05mm. • Precision ground and moulded inserts — all available with chip control. <p>O.D. Application</p> <ul style="list-style-type: none"> • Integral shank toolholders and modular KM heads are available. • Cutting depths from 14–26mm. <p>I.D. Application</p> <ul style="list-style-type: none"> • Boring bars with 25mm minimum bore diameter. • Cutting widths from 2–6,35mm. 	<p>Minimum Face Groove Diameter Capabilities</p> <ul style="list-style-type: none"> • 16mm minimum diameter. • Unlimited maximum diameter. <p>Cutting Width Range</p> <ul style="list-style-type: none"> • Cutting widths from 2–10,05mm. <p>Cutting Depth Range</p> <ul style="list-style-type: none"> • Cutting depths from 12mm–24mm.
A3™ Deep Grooving generally recommended for cutting depth/width ratios of more than 1,5		<p>Inserts</p> <ul style="list-style-type: none"> • Cutting widths from 2,36–10,05mm. • Precision ground and moulded inserts — all available with chip control. <p>O.D. Application</p> <ul style="list-style-type: none"> • Integral shank toolholders and modular KM heads are available. • Cutting depths from 10–32mm. <p>I.D. Application</p> <ul style="list-style-type: none"> • Boring bars with 32mm minimum bore diameter. 	<p>Minimum Face Groove Diameter Capabilities</p> <ul style="list-style-type: none"> • 25mm minimum diameter. • Unlimited maximum diameter. <p>Cutting Width Range</p> <ul style="list-style-type: none"> • Cutting widths from 3–6,35mm. <p>Cutting Depth Range</p> <ul style="list-style-type: none"> • Cutting depths from 10–32mm.
A2™ Cut-Off	<p>Cut-Off Capabilities</p> <ul style="list-style-type: none"> • Cut-off widths from 1,4–8mm. • Left- and right-hand styles with 6–16° lead angles. • Self-clamping blades and screw-clamping integral shank toolholders are available. • Single-edge inserts for maximum depth capability. 		

	Grooving and Turning	Undercutting	Profiling
Application			
Top Notch™ Grooving generally recommended for cutting depth/width ratios of 1,5 or less		Top Notch Undercutting Capabilities <ul style="list-style-type: none"> • Undercutting insert widths from 2,4–4mm. • Economical double-ended inserts. 	Recommended for Moderate to Heavy Stock Removal at Shallow Profile Depths <p>Full Radius Inserts</p> <ul style="list-style-type: none"> • Cutting widths from 1,57–6,35mm. • Cutting depths from 2,39–6,35mm. <p>O.D. Application</p> <ul style="list-style-type: none"> • Integral shank toolholders and KM heads are available.
A4™ Grooving and Turning	Recommended for Heavy Stock Removal, Particularly in Turning Applications <p>Inserts</p> <ul style="list-style-type: none"> • Cutting widths from 2–10,05mm. • Double-ended, precision ground, and moulded inserts — all available with chip control. <p>O.D. Application</p> <ul style="list-style-type: none"> • Integral shank toolholders and modular KM™ heads are available. • Cutting depths from 14–26mm. <p>I.D. Application</p> <ul style="list-style-type: none"> • Boring bars with 25mm minimum bore diameter. • Cutting widths from 2–6,35mm. 		Recommended for Heavy Stock Removal <p>Full Radius Inserts</p> <ul style="list-style-type: none"> • Cutting widths from 2–10,05mm. <p>O.D. Application</p> <ul style="list-style-type: none"> • Integral shank toolholders and modular KM heads are available. • Cutting depths from 14–26mm.
A3™ Deep Grooving generally recommended for cutting depth/width ratios of more than 1,5	Recommended for Light Cutting <p>Inserts</p> <ul style="list-style-type: none"> • Cutting widths from 2,36–10mm. • Precision ground and moulded inserts — all available with chip control. <p>O.D. Application</p> <ul style="list-style-type: none"> • Integral shank toolholders and modular KM heads are available. • Cutting depths from 10–32mm. <p>I.D. Application</p> <ul style="list-style-type: none"> • Boring bars with 32mm minimum bore diameter. 	<p>Full Radius Undercutting</p> <ul style="list-style-type: none"> • Full radius inserts with cutting widths from 3–8mm at 45° lead angle. <p>35° Insert Undercutting</p> <ul style="list-style-type: none"> • 35° V-form inserts for profiling undercuts. • Toolholder lead angles of 45°, 93°, and 117,5°. 	Recommended for Light Cutting <ul style="list-style-type: none"> • Full radius inserts with cutting widths from 3–8mm. • 32mm maximum cutting depth. • Integral shank toolholders and modular KM heads are available. • 35° V-form inserts are also available.
A2™ Cut-Off			

Grooving and Cut-Off

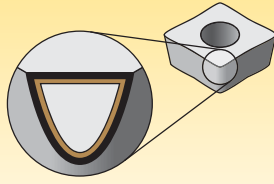

Reduce cycle times. High speed and feed capability. Long tool life. New multilayer coating provides better wear resistance.

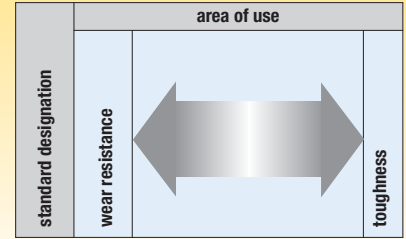

Grade

Coating		Grade Description	area of use													
			standard designation	05	10	15	20	25	30	35	40	45	wear resistance	toughness		
KCUI10		<p>Composition: An advanced multilayer PVD coating over a very deformation-resistant unalloyed carbide substrate. The new and improved coating improves edge stability with wide range speed and feed capabilities.</p> <p>Application: The KCUI10 grade is ideal for finishing to general machining of most workpiece materials at a wide range of speed and feed capabilities. Excellent for machining most steels, stainless steels, cast irons, non-ferrous materials, and super alloys with improved edge toughness and higher cutting speed/feed capability.</p>	P													
			M													
			K													
			N													
			S													
			H													
KC5010		<p>Composition: An advanced PVD TiAlN coating over a very deformation-resistant unalloyed carbide substrate.</p> <p>Application: The KC5010 grade is ideal for finishing to general machining of most workpiece materials at higher speeds. Excellent for machining most steels, stainless steels, cast irons, non-ferrous materials, and super alloys under stable conditions. It also performs well machining hardened and short chipping materials.</p>	P													
			M													
			K													
			N													
			S													
			H													
KC5510		<p>Composition: An advanced PVD TiAlN-coated fine-grain tungsten carbide grade.</p> <p>Application: The KC5510 grade is specifically engineered for the productive machining of high-temp alloys. The fine-grained tungsten carbide 6% cobalt substrate has excellent toughness and deformation resistance while the advanced PVD coating enables metal cutting speeds double those of conventional PVD-coated cutting tools.</p>	P													
			M													
			K													
			N													
			S													
			H													
KCUI25		<p>Composition: An advanced PVD grade with hard AlTiN coating and ultra-fine-grain unalloyed substrate. The new and improved coating improves edge stability with wide range speed and feed capabilities.</p> <p>Application: The KCUI25 grade is ideal for general machining of most steels, stainless steels, high-temp alloys, titanium, irons and non-ferrous materials, in a wide range of speeds and feeds, with improved edge toughness for interrupted cut and high feed rates.</p>	P													
			M													
			K													
			N													
			S													
			H													
KC5025		<p>Composition: An advanced PVD TiAlN-coated grade with a tough, ultra-fine-grain unalloyed substrate.</p> <p>Application: For general-purpose machining of most steels, stainless steels, high-temp alloys, titanium, irons, and non-ferrous materials. Speeds may vary from low to medium and will handle interruptions and high feed rates.</p>	P													
			M													
			K													
			N													
			S													
			H													
KC5525		<p>Composition: Advanced PVD TiAlN-coated fine-grain high-cobalt carbide grade.</p> <p>Application: The KC5525 grade utilises the same advanced PVD coating as the KC5510 grade in conjunction with a fine-grained tungsten carbide 10% cobalt substrate. The higher cobalt enables added security in interrupted cuts while the fine-grained WC maintains hardness-resisting deformation at higher speeds. Designed for medium to heavy interruptions in high-temp alloys.</p>	P													
			M													
			K													
			N													
			S													
			H													



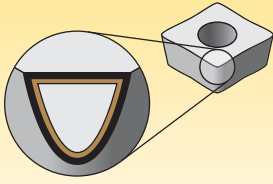

Reduce cycle times. High speed and feed capability. Long tool life. New multilayer coating provides better wear resistance.

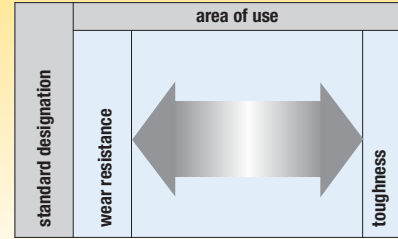

Grooving and Cut-Off

Grade

Coating		Grade Description	area of use												
			05	10	15	20	25	30	35	40	45	wear resistance		toughness	
KC5410		Composition: PVD TiB ₂ coating over a thermal deformation-resistant unalloyed substrate. Application: The KC5410 grade is designed for roughing, semi-finishing, and finishing of free machining (hypoeutectic <12.2% Si) aluminium, aluminium alloys, and magnesium alloys. Harder than TiN and TiAlN coatings, TiB ₂ has an extremely smooth surface for improved surface friction, chip flow, and wear and built-up edge resistance. Unalloyed and fine-grained offering sharp edges and excellent edge integrity. Inserts with a ground periphery are polished before coating; moulded inserts have a light hone.										N			
	C3-C4														
KC9110		Composition: Specially engineered, cobalt-enriched carbide grade with thick K-MTCVD-TiCN coating layer, an Al ₂ O ₃ layer of controlled grain size, and outer layers of TiCN and TiN for maximum abrasion and wear resistance for high-speed machining. Application: An excellent finishing to medium machining grade for a variety of workpiece materials including most steels, ferritic and martensitic stainless steels, and cast irons. A balanced combination of deformation resistance and edge toughness. The smooth coating resists built-up edge and microchipping. For rougher cutting, use the KC9125 grade.										P			
	C3, C7												K		
KC9125		Composition: A tough cobalt-enriched carbide grade with a newly designed multilayer K-MTCVD TiCN/Al ₂ O ₃ -TiCN-TiN coating with superior interlayer adhesion. Application: General-purpose turning grade for most steels and ferritic and martensitic stainless steels. The substrate design ensures adequate deformation resistance along with excellent bulk toughness and insert edge strength. Coating layers offer wear resistance over a wide range of machining conditions and reduce frictional heat, minimise microchipping, and improve workpiece surface finishes. Performs well in moderately heavy roughing to semi-finishing cuts. Use the KC9110 grade for finishing cuts.										P			
	C2-C3, C6-C7												K		
KC9320		Composition: A proprietary specially toughened MTCVD-TiCN and Al ₂ O ₃ coating over a wear-resistant substrate. Application: KC9320 is specifically engineered to maximise coating adhesion and edge strength making this grade ideal in wet interrupted cutting of ductile and gray irons. It can be in a wide range of applications from finishing to roughing to maximise productivity wherever strength and reliability are needed.										P			
	C3-C4														
KY3500		Composition: Pure silicon nitride grade. Application: Maximum toughness; used at high feed rates for rough machining of grey cast iron, including machining through interruptions.										K			
	C2														
KD1400		Composition: An ultra-fine-grain polycrystalline diamond (PCD) tip brazed onto a carbide substrate. Application: Designed for general-purpose turning of primarily non-ferrous materials. It can be applied over a wide range of continuous to interrupted cuts where superior surface finish is needed. Use on low to medium silicon-content aluminum alloys, non-metallics, copper, and brass- and zinc-based alloys. The ultra-fine-grain diamond particle size enables superior surface finishes while ensuring the best mechanical shock resistance of any PCD cutting tool.										N			
	C4												S		

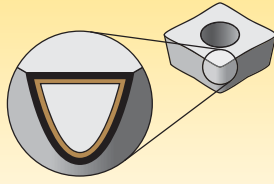

Reduce cycle times. High speed and feed capability. Long tool life. New multilayer coating provides better wear resistance.

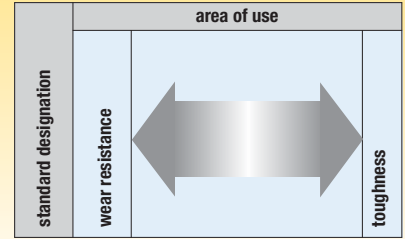

Grade	Coating	Grade Description	area of use																			
			05	10	15	20	25	30	35	40	45											
KD1405		Composition: A pure CVD deposited diamond sheet tool directly brazed to a carbide substrate. Application: The KD1405 grade is Kennametal's and the industry's most abrasion-resistant tool material for non-ferrous and non-metallic materials. The KD1405 grade inserts are not as tough as the KD1400 and KD1425 grades but can withstand moderate interruptions when turning and traditional face milling operations.																				
	C4		N																			
KB1630		Composition: A high CBN content, PCBN tip brazed onto a carbide insert. Application: The KB1630 grade is designed for roughing to finishing in interrupted cuts on hardened steels (>45 HRC). It can also be applied on grey cast iron, chilled irons, high-chrome alloyed steels, and sintered powdered metals. The tipped PCBN insert is available in a wide range of insert styles including positive rake geometries that are ideally suited for boring applications.																				
	—		K																			
			S																			
			H																			
KB5625		Composition: A PVD TiAlN coating over a low content, PCBN tip brazed onto a carbide insert. Application: Designed for roughing to finishing of hardened steels (>45 HRC). Use on bearing steel, hot and cold work tool steels, high-speed steels, die steels, case hardened steels, carburised and nitrided irons, and some hard coatings.																				
	C4, C8																					
			H																			



A2™ Cut-Off • High-Performance Tools to Maximise Productivity!

The A2 platform is the ideal system for parting operations on a wide variety of workpiece materials. It works well in smooth and interrupted cuts in both wet and dry operations. Now it is available in KCU25™ for superior edge toughness and excellent wear resistance.

Features and Benefits

Innovative A2 Insert Design

- V-prisms on both top and bottom enable higher clamping force to prevent insert movement, even when cutting at high-feed rates.
- The cutting edge has a molded-in chipbreaker ramp to direct chips away from the blade, extending blade life.
- Positive rake cutting action combined with Kennametal's high-performance PVD coatings result in superior tool life and chip control.

A2™ Insert Stop Design

- As cutting forces increase, clamping forces also increase for secure holding power.
- Fixed insert stop ensures solid seating with every index and delivers up to 30% longer life.
- Cutting height is accurately controlled for maximum reliability and performance on even small-diameter parts.

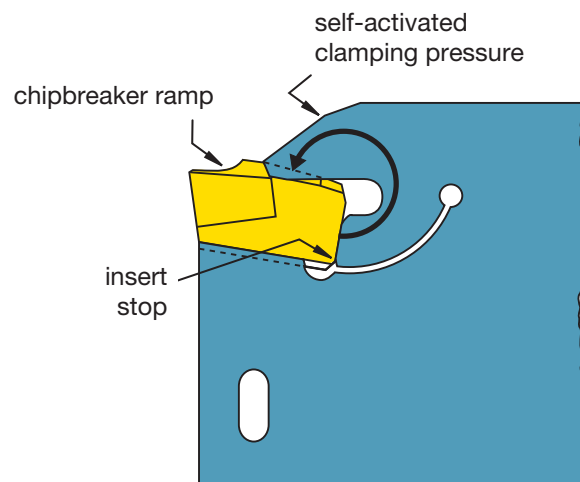

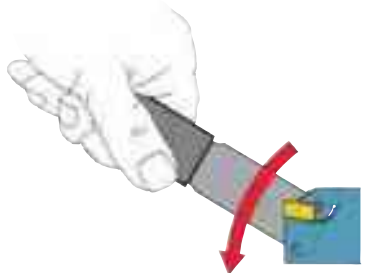
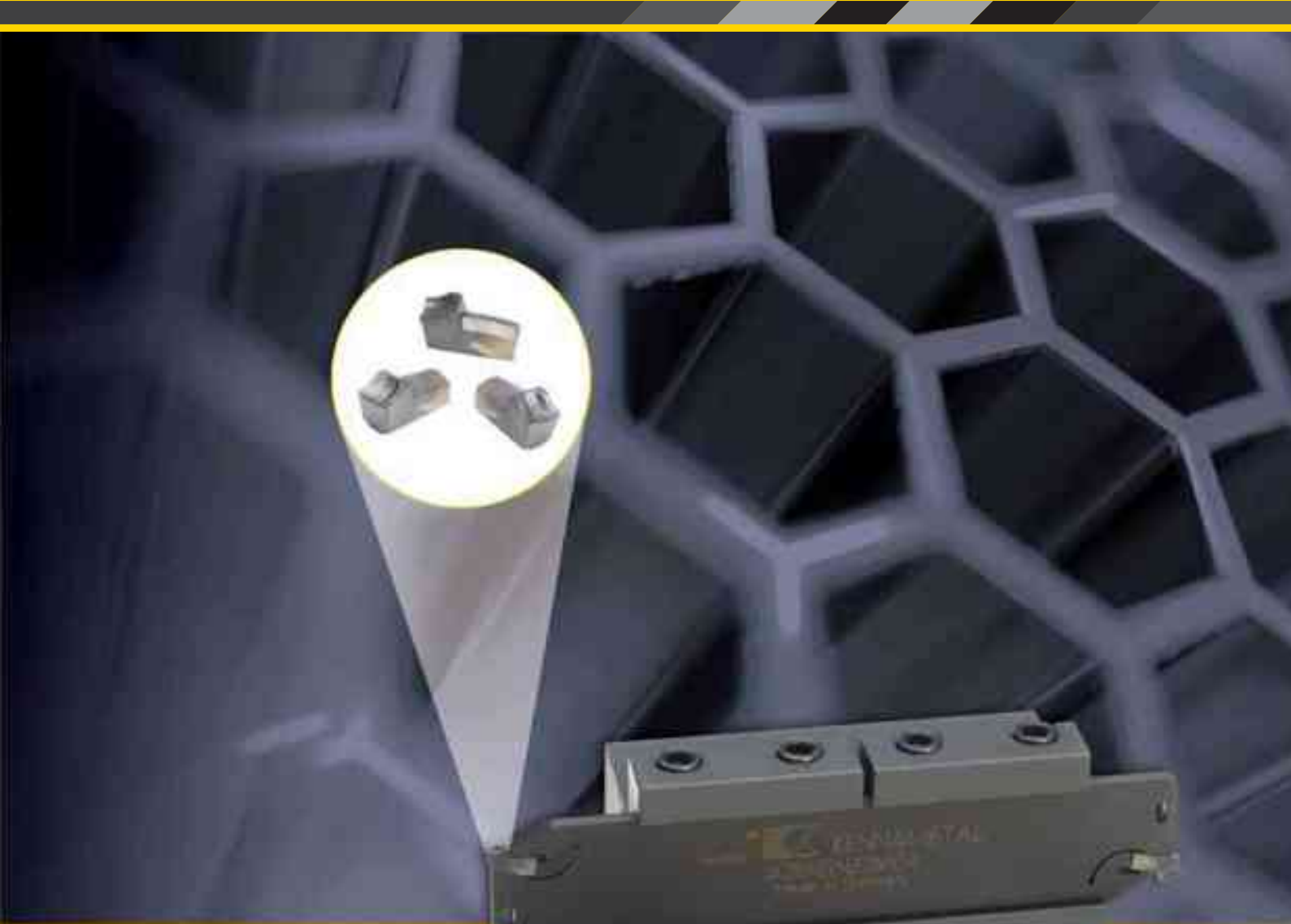

Quick and Easy Insert Indexing

- A convenient indexing wrench is available to minimise downtime by enabling fast removal and insertion without damage to the cutting edge.

Step 1 • Select insert width and holder type

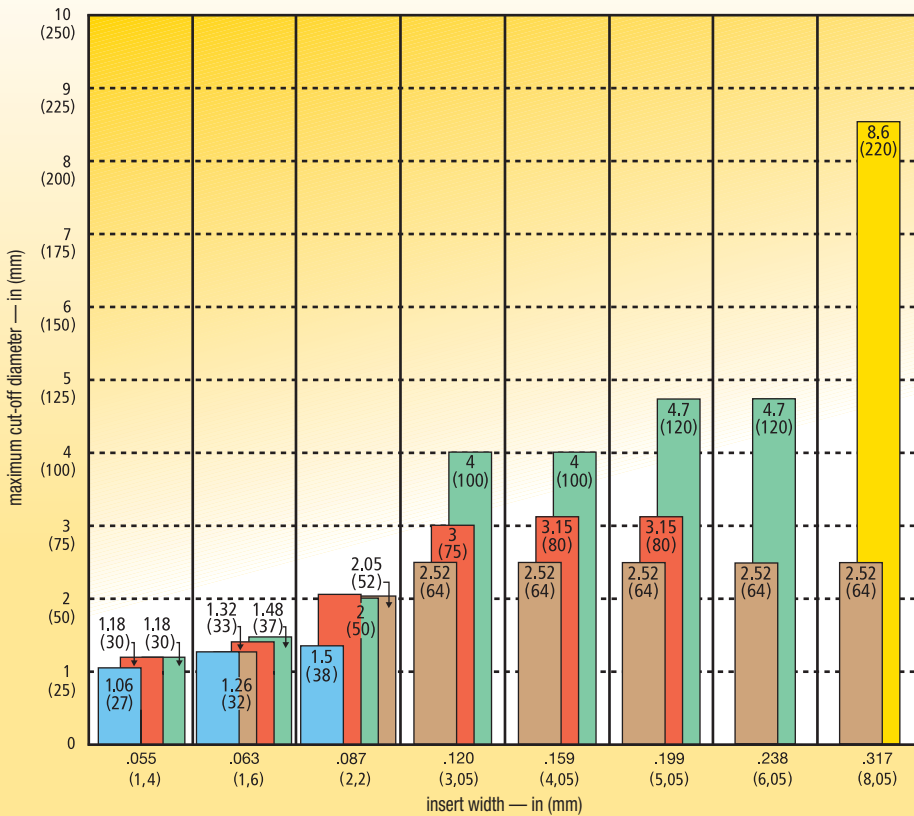

blade height	
19mm	
26mm	
32mm	
52mm	
Integral Shank Toolholders	

What you need to know:

- Cut-off diameter.
- Part/machine requirements.

For required cut-off diameter, select insert width and holder type based on the part and machine requirement:

- To maximise rigidity, select the largest possible blade height or an integral shank toolholder.
- Diameters shown are for cut-off to centre. Maximum cut-off depth to a through-hole depth is one half of the diameter.
- To determine depth capability for cut-off to a through-hole on integral shank or reinforced blades, please refer to listing for that tool in this catalogue.

Toolholder Type

blade: (self-clamping)	blade: (self-clamping, reinforced version)	toolholder: (with clamping screw)
	 Available in 26mm and 32mm heights	
<ul style="list-style-type: none"> • Frequently used tool. • Two insert seats. • Deepest depth-of-cut capability. 	<ul style="list-style-type: none"> • Efficient tooling solution with improved stability. • Limited depth-of-cut capability. 	<ul style="list-style-type: none"> • Shank tool with the highest stability. • Limited depth of cut. • Single insert seat.

Step 2 • Select the insert lead angle

- Part type.
- Burr and centre stub considerations.
- Cut-off to centre or through hole.

	neutral (0°)	right/left 6-10°	right/left 15-16°
insert type			
recommended application	<ul style="list-style-type: none"> • For cutting off solid workpieces. • Centre stub will form on cut-off part. • Eliminates lateral deflection. • Best for deep cut-off depths. 	<ul style="list-style-type: none"> • For cutting off solid workpieces with reduced formation of centre stub. • For cut-off to a through-hole with reduced burr. 	<ul style="list-style-type: none"> • For thin-walled workpieces. • For cutting off small diameter workpieces with minimal burr or centre stub.
tool life	Best tool life	Better tool life	Good tool life